

THE SEMINAR OF JACQUES LACAN

BOOK XVI

From an Other to the other

1968-1969

Translated by Cormac Gallagher from unedited French manuscripts

FOR PRIVATE USE ONLY

Seminar 1: Wednesday 13 November 1968

*The essence of psychoanalytic theory is a discourse without words.
(L'essence de la théorie psychanalytique est un discours sans parole)*

(Written on the board)

We find ourselves here again this year for a seminar for which I chose the title *From an Other to the other (D'un Autre à l'autre)* to indicate the major reference points around which my discourse ought, properly speaking, to turn. That is why this discourse is crucial at the moment of time that we are at. It is so in as much as it defines what is involved in this discourse called the psychoanalytic discourse, whose introduction, whose coming into play at this time brings so many consequences with it.

A label has been put on this process. It has been called structuralism, a word that moreover was not necessary on the part of the publicist who suddenly, not so many months ago, God knows, put it forward in order to encompass a certain number of people whose labour had for a long time marked out some avenues of this discourse.

Thus it is the doing of what I have just called a publicist - everyone knows the play on words that I have made about "*poubelliciation*" - that a certain number of us, thanks to the labour of this agency, find ourselves together in the same dustbin (*poubelle*). One could have more disagreeable company! In truth, those that I find myself connected to being people for whose labour I have the greatest esteem, I could not in any case find myself uncomfortable in it, especially, since we know little bit about what is involved in dustbins in this period dominated by the genius of Samuel Beckett. For me

personally, after having now lived almost 30 years, in three sections of fifteen, ten and five years, in three psychoanalytic societies, I know a little bit about what is involved in living with household refuse.

As regards structuralism, in truth one can understand the unease that may be produced among some people from the treatment that people pretend to inflict from the outside on our common habitat, and also that people may want to get out of it to stretch their legs a little. It remains, nevertheless, that ever since this impatience seems to all appearances to be taking hold of some people, I notice that I do not find myself all that uncomfortable in this basket, since moreover in my eyes it does not (8) seem to me that this structuralism should be identified to anything other than what I call very simply seriousness, and in no way certainly to anything that resembles in any way what one could call a philosophy, if by this word there is designated a vision of the world, or even some way of assuring on the right or the left the positions of a thinking. Let it suffice, to refute the first case, if it is true that as a psychoanalyst I cannot in any way claim to introduce in any fashion what is ridiculously called a psychoanalytic anthropology - it would be enough to recall, at the very entry into this domain of constitutive truths everything that psychoanalysis brings into this field, namely, that there is no union of man and woman without castration:

- a) determining by way of phantasy, precisely, the reality of the partner for whom it is impossible,
- b) without castration operating, in this sort of hiding place that posits it as a truth in the partner for whom it has been really spared, apart from some accidental excesses.

Let us strongly insist that, developing this formula from Genesis that God created them - there is also created *him* - man and woman - make no mistake, God knows why! - in the case of one the impossibility of the accomplishment of castration comes to posit itself as determining her reality; in the other, the worst thing that is threatened as being possible does not need to happen to be true, in the sense that this term offers no recourse.

This simple reminder, it seems, implies that at least at the heart of the field that is apparently ours, no harmony, however we may designate it, is in place, that assuredly

some purpose is required of us which is precisely that of a suitable discourse. In order to sustain it, we will have in a way to ask ourselves the sort of question from which all philosophy started. Faced with so much knowledge, which is not without its value and efficacy, what is it that can distinguish this discourse, guaranteed of itself, grounding itself on a criterion that thinking would take as its own measure, and would make it deserve to be entitled *episteme*: science. We are brought, even if it is only at first by this challenge that I have just outlined as that put by truth to the real, to a greater prudence in this approach of harmonising thinking with itself.

A rule of thinking that has to guarantee itself from non-thinking as being that which may be its cause, this is what we are confronted with in the notion of the unconscious. It is only in the measure of the beyond-sense of remarks and not, as is imagined and as the whole of phenomenology supposes, from sense, that I am as thinking. My thinking cannot be regulated – whether one adds or not alas! – as I wish; it is regulated. In my act, I am not trying to express it but to cause it. But it is not a matter of the act. In the discourse, I do not have to obey its rule, but find its cause. It is in (9) the inter-sense – and you can understand this in as obscene a way as you may imagine – there is the being of thinking. What has passed through my thinking, is the cause. It allows to pass purely and simply what has been, as being, and this from the fact that always and ever, wherever it has passed, it has always passed producing effects of thinking.

“It is raining, *il pleut*” is a thinking event each time it is pronounced, and the subject of it is first of all this *il*, this *hile*, I would say, that it constitutes in a certain number of meanings. And that is why this “it” finds itself comfortable in everything that follows because by “it is raining” you can understand “it is raining primary truths”, “there is some abuse, *il y a de l’abus*”; especially by confusing rain, a meteor, with *pluvia*, *aqua pluvia*, rain and the water that one collects from it. The meteor lends itself to metaphor and why? Because it is already made up of signifiers. It is raining. The being of thought is the cause of thinking *qua* beyond sense. It was always and ever the being of a thinking before.

Now using this structure rejects any promotion of infallibility. It is only helped precisely from the gap or rather from the very process because there is a process of

gap, and it is the process helped by the structure of the practice, but it can only be helped by it by following it, which does not mean in any way going beyond it, except by allowing it to be grasped in the consequences that fix it to time, to the very point that the reproduction of the process comes to a halt. This means that it is when it stops that the result is seen. And this is what explains, let us say here with a discreet touch in passing, that all art is defective. It is from collecting what, at the point where its failure to be completed is hollowed out, it is from collecting this that it takes its force. And that is why music and architecture are the supreme arts – I mean supreme technically, as being at the height of the basal, producing the relation of the harmonic number with time and space, precisely from the angle of their incompatibility. Because the harmonic number is now only, as is well known, a strainer, since it does not hold on either to the one or to the other, neither to this time nor to this space.

This is what structuralism takes seriously. It takes seriously the fact of knowledge as cause, as cause in thinking and, most usually, it has to be said, in a delusional perspective. Do not be frightened, these are opening remarks, reminders of certainties, not truths. And I would like, before introducing today the schemas from which I intend to start, to mark that if something here and now ought already to be in the palm of your hand, it is what I took the care to write earlier on the board about the essence of the theory. The essence of psychoanalytic theory is the function of discourse and very precisely because of something that may appear new to you, or at least paradoxical, that I am saying that it is without words. It is a matter of the essence of the theory because this is what is at stake.

(10) What is the state of theory in the psychoanalytic field? About this, I hear strange echoes being bruited around me. There is no lack of misunderstanding. On the pretext that by positing a whole field of thought as manipulation, I seem to be putting in question traditional principles. I mean – and this is expressed astonishingly because it is in places or in minds that are close to me – by something or other called “theoretical impossibility”. Indeed, did I not find this at a turn in some lines that what I one day announced in a context that clearly said what it meant, *that there is no universe of discourse*, so then why tire ourselves out, people seem to conclude. No doubt it would be less important in my eyes to correct my statement, because it does not lend itself to any ambiguity, and it is hard to see how the fact that one can state

precisely what has been stated, that there is no point of closure in a discourse, that discourse is for all that, far from that, neither impossible, nor even simply devalued. It is precisely by starting from there that you are responsible for this discourse, and especially for managing it properly, taking into account what is meant by this statement that there is no universe of discourse. There is certainly nothing therefore in this respect to be corrected by me, except simply to come back to it to take the following steps; of what consequences are induced from the discourse that has already been put forward but also perhaps to return to what is meant by the fact that being attached to the degree that an analyst may be to the conditions of this discourse, he can at every moment be in a position to show its flaws.

There was a time – allow me a little interlude before getting into this domain – when I took the example of the pot, not without there being such a scandal that I left this pot, as I might say, in the margin of my *Ecrits*. What was at stake was the fact that the pot is, in a way, the tangible image that it is this meaning modelled by itself, thanks to which, manifesting the appearance of a form and a content, it allows there to be introduced into thinking the idea that it is the contents that is the meaning, as if thinking showed here this need to imagine itself as having to contain something else, for this is what the term “to contain” designates when it is highlighted with regard to an inopportune act. The pot, and I called it mustard in order to remark that far from necessarily containing any, it is precisely because it is empty that it takes on its value as a mustard pot. Namely, that it is because the word “mustard” is written on it, but mustard which means that there is much delay (*moult lui tarde*) for this pot before it reaches its eternal life as a pot which begins at the moment when this pot will be holed. Because it is under this appearance throughout the ages, that we find it in digs, namely, by searching in tombs something that will bear witness to us about the state of a civilisation. The pot is holed, it is said, as a homage to the dead person and so that a living person cannot make use of it. Of course it is a reason. But there is perhaps another one which is the following; it is that this hole is intended to produce, so that this hole produces, illustrating the myth of the Danaï. It is in this state that, (11) this pot, when we have resurrected it from its burial place, occupies a place of honour on the shelf of the collector and, in this moment of glory, for it just as much as for God, it is in this glory that it reveals its nature. The structure of the pot – I am not saying its material – appears there as what it is, namely, correlative to the function of

the tube and the drum. And, if we are going to search for preformations in nature, we will see that for a horn or a shell, it is still there, after the life has been extracted from it, that it shows what its essence is, namely, its capacity for producing sound.

Entire civilisations are no longer represented for us except by these little pots in the form of a head or again of some animal, covered by signs that are impenetrable to us, for lack of correlative documents. And here we sense that the meaning, the image is altogether outside, that what is left to being inside is precisely what lies in the tomb in which we find it, namely, precious materials, perfumes, gold, incense and myrrh as they say. The pot explains the meaning of what is there by virtue of what? By virtue of a use value, let us rather say of an exchange value, with another world and another dignity, of a token value. That it should be in pots that we find the manuscripts of the Dead Sea is something to make us sense that it is not the signified that is within, it is very precisely the signifier. And it is with it that we have to deal when it is a matter of what is at stake for us, namely, the relationship between discourse and the word in analytic efficacy.

Here, I ask you to allow me a short circuit at the moment of introducing what, I think, is going to image for you the unity of the theoretical function in this approach rightly or wrongly called structuralist. I shall appeal to Marx whose remarks I have had a lot of trouble not introducing earlier, importuned as I have been for a long time about him, into a field in which he is nevertheless perfectly in his place. I am today going to introduce in connection with the o-object the place in which we have to situate his essential function. Because it is necessary, I will proceed by way of a homologous stage and I will first of all recall something that was, by labours that are still recent, precisely and up to the disavowal of the author designated as structuralist, was perfectly highlighted, and not too far from here, in a commentary on Marx. The question is posed by the author whom I have just evoked of what the object of *Capital* is. We are going to see what, in a parallel way, psychoanalytic investigation allows there to be stated on this point.

Marx starts from the function of the market. His novelty is the place that he situates labour in it. It is not the fact that labour is new that allows his discovery, it is the fact that it is bought; that there is a labour market. This is what allows him to demonstrate

what is inaugurating in his discourse - what is called surplus value. As it happens this approach suggests the revolutionary act that we know about, or rather that we know (12) very badly, because it is not sure that taking power resolved what I will call the subversion of the capitalist subject expected from this act. But for the moment it matters little to us. It is not sure that the Marxists did not in fact undergo many inauspicious consequences from it. The important thing is what Marx is designating and what his approach means. Whether his commentators are structuralist or not, they still seem indeed to have demonstrated that he for his part is structuralist. Because it is properly by being at the point, for his part, as a being of thought, being at the point that the dominance of the labour market determines, that there is brought out as cause of his thinking this function, an obscure one it has to be said – if this obscurity can be recognised in the confusion of the commentary – which is that of *surplus value*. The identity of discourse with its conditions is what I think is going to find some clarification from what I am going to say about the analytic approach.

No newer than labour was in the production of merchandise, is the renunciation of enjoyment (*jouissance*), whose relation to labour I do not have to define any further. Since, from the beginning and quite contrary to what Hegel says, or seems to say, it is what constitutes the master who clearly intends to make of it the principle of his power. What is new is that there is a discourse that articulates this renunciation and which makes appear in it – for this is the essence of the analytic discourse – what I would call the function of the *surplus enjoying* (*plus de jouir*). This function appears because discourse occurs, because what it demonstrates in the renunciation of enjoyment is an effect of discourse itself. To accentuate things, it must be supposed that in the field of the Other, there is this market, if you wish, which adds up its merits, its values, the organisation of choices, of preferences which implies an ordinal, indeed cardinal structure. Discourse holds the means of enjoying in so far as it implies the subject. There would be no reason of subject, in the sense that one can say reasons of state, if there were not a correlative in the market of the Other, which is that a *surplus enjoying* is established that is captured by some people.

A discourse must be pushed very far to demonstrate how the *surplus enjoying* depends on stating, is therefore produced by discourse, so that it appears as an effect. But in fact this is not something very new to your ears if you have read me, because it

is the object of my writing on *Kant with Sade* in which the proof is given of the total reduction of this surplus enjoying to the act of applying to the subject the term \circ of the phantasy, through which the subject can be posited as cause of itself in desire.

I will develop this in the time to come by a return to this wager of Pascal that illustrates so well the relation of the renunciation of enjoyment to this element of wager in which life in its totality is itself reduced to an element of value. A strange way of inaugurating the market of enjoyment, to inaugurate it, I am clearly saying, in the field of discourse. But after all is this not a simple transition from what we have (13) just now seen being inscribed in history in this function of goods devoted to the dead? Moreover do we not have here what is now in question for us. We have to deal with theory in as far as it has been lightened precisely by the introduction of this function of the *surplus enjoying*. Around the *surplus enjoying* there is played out the production of an essential object whose function it is now a matter of defining, it is the \circ -object.

The crudeness of the echoes received at the introduction of this term is and remains for me the guarantee that it is indeed in effect of the order of efficacy that I bestow on it. In other words, there is a well known, well marked and celebrated passage in which Marx savoured, during the time he spent developing his theory, the opportunity to see the survival of the living incarnation of its miscognition!

I stated: *the signifier is what represents the subject for another signifier*. This like every correct definition, namely, is required. It is required that a definition should be correct and that a teaching should be rigorous. It is quite intolerable, at the moment when psychoanalysis is called on to give to something that you must not think I intend to elide, to the crisis that traverses the relation of the student to the university, it is unthinkable that one should respond by the statement that there are things that one cannot in any way define in a knowledge. If psychoanalysis cannot state itself as a knowledge and be taught as such, it has strictly nothing to do in a place where nothing else is at stake. If the market of knowledge is very properly shaken by the fact that science contributes to it this unit of value that allows there to be plumbed what is involved in its exchange even in its most radical functions, it is certainly not in order for something that can articulate something about it, namely, psychoanalysis should

present itself by throwing in the towel. All the terms that may be employed in this connection, whether they are those of “non-conceptualisation” or any other evocation of some impossibility or other, can only designate in any case the incapacity of those who put them forward. It is not because the strategy with the truth in which the essence of therapy may reside does not lie in any particular intervention described as interpretation, a point where undoubtedly all source of particular functions, of lucky operations in the order of the variable can find their opportunity but only have sense by being situated at the precise point where theory gives them their weight.

This is what is well and truly at stake here. It is in the discourse on the function of the renunciation of enjoyment that there is introduced the term of o-object. The *surplus enjoying* as a function of this renunciation under the effect of discourse, is what gives its place to the o-object, like in a market, namely, because it defines some object of human labour as merchandise. Just as each object carries in itself something of (14) *surplus value*, in the same way *surplus enjoying* is what allows the isolation of the o-object.

What are we doing in analysis, if not establishing, by the rule, a discourse of such a kind that the subject suspends what on it? Precisely his function as subject. Namely, that he is dispensed from sustaining his discourse with an “I say” because it is a different thing to speak and to posit “I say what I have just stated”. The subject of the statement says “I say”, says “I posit”, as I do here in my teaching. I articulate this word; it is not poetry; I am saying what is written here and I can even repeat it, which is essential, in the form in which by repeating it, to vary it I add that I have written it.

Here then is the subject dispensed from sustaining what he states. Is it then in this way that he is going to come to this purity of the word, this full word of which I spoke in a period of evangelisation, it has to be said, for the discourse called the Rome discourse. To whom was it addressed if not to ears that were most closed to hearing it. I will not qualify what made these ears provided with these opaque qualities. This would be to make a judgement that could not be in any way other than offensive.

But notice that it is in speaking about *The Freudian thing*, that I happened to launch myself into something that I myself called a prosopopoeia? It is a matter of the truth

stating: "For you then I am the enigma of her who vanishes as soon as she appears; men who try so hard to hide me under the tawdry finery of your proprieties. But I am prepared to believe that your embarrassment is sincere." I note that the term "embarrassment" was highlighted for its function elsewhere. "For even when you take it upon yourselves to serve as my heralds, you place no greater value on wearing my colours than your own, which are like what you are, phantoms that you are. Where then will I pass into you? Where was I before I entered you? Perhaps one day I will tell you." It is discourse that is at stake here. "But so that you will find me where I am, I will teach you by what sign you will recognise me. Men, listen, I am giving you the secret. Me, the truth, I speak (*Moi, la vérité, je parle*)."

I did not write, "I say". What speaks undoubtedly, if it came, as I also wrote ironically, the analysis, of course, would be closed. But it is precisely what does not happen, or what when it does happen deserves to be punctuated in a different way. And for that reason we must take up again what is involved in this subject that is here put in question by an artificial procedure, of whom it is demanded, in effect, not to be the one who sustains everything that is advanced. It must not be believed nevertheless that he is dissipated, for the psychoanalyst is very precisely there to represent him, I mean to maintain him throughout the time that he is not able, in effect, to place himself as regards the cause of his discourse.

Thus it is that it is a matter now of referring to fundamental formulae, namely, to those that define the signifier as being what represents a subject for another signifier. What does that mean? I am surprised that no one has ever remarked in connection (15) with this proposition that the result, as a corollary, is that *a signifier cannot represent itself*. Of course this is not new either because in what I articulated about repetition, this indeed is what is at stake. But there we have to pause for a moment in order to grasp it clearly in real life. What can be meant here in this sentence by this "itself" of the signifier? Note well that when I speak about the signifier I am speaking about something opaque. When I say that the signifier must be defined as what represents a subject for another signifier that means that no one will know anything about it except the other signifier. And the other signifier has no head, it is a signifier. The subject is stifled, effaced, immediately, at the same time as it appears. It is a matter precisely of seeing why something of this subject which disappears in

emerging, produced by one signifier in order to be immediately extinguished by another, how somewhere this something can be constituted which can at the limit be taken as *Selbstbewusstsein*, for something that is satisfied to be identical to itself. Now, very precisely, what this means, is that the signifier in whatever form it is produced, in its presence as subject of course, cannot connect up with its representative signifier without there being produced this loss of identity that is properly speaking called the o-object. This is what Freud's theory about repetition designates. As a result of which nothing is identifiable from the recourse to enjoyment in which, by virtue of the sign, something different comes to its place, namely, the stroke that marks it. Nothing can be produced there without an object being lost in it .

A subject is what can be represented by a signifier for another signifier. But is this not something traced out on the fact that as an exchange value the subject in question, in what Marx is deciphering, namely, economic reality, the subject of exchange value is represented for what? Use value. And it is already in this gap that there is produced, that there falls what is called surplus value. This loss is all that counts at our level. Henceforth no longer identical to himself the subject certainly no longer enjoys but something is lost that is called *surplus enjoying*; it is strictly correlative to the coming into play of what then determines everything involved in thinking. And in the symptom what else is involved. Namely, in terms of being more or less at ease in approaching this something that the subject is quite incapable of naming. But if he does not make a circuit of it he will not even know what to do. He does not simply have to deal with relations to his fellows, [but?] with his most profound relation, with the relation that is called vital, and for which economic references and configurations are much more suitable than the often distant, even though of course not completely wrong ones offered to Freud, those of thermodynamics.

(16) Here then is the way, the element that can allow us to advance into what is involved in analytic discourse. If we have *a priori* posited theoretically and without needing a long recurrence to constitute these premises, if what is at stake in the definition of the subject as caused by the inter-signifying relationship, of something that, in a way, forever prohibits us from grasping it, here also is the opportunity to perceive what gives it this unity, let us call it provisionally preconscious, not

unconscious, the one that has permitted up to the present the subject to be sustained in his so-called self sufficiency. Far from being self sufficient, it is around the formula namely, it is around the being of the o , around the *surplus enjoying*, that there is constituted the relationship that allows us up to a certain point to see there being created this soldering, this precipitation, this freezing which means that we can unify a subject as subject of a whole discourse. I will draw on the blackboard something that images in a certain way what is at stake on this occasion.

$$\frac{S^1}{S} \longrightarrow S^2 \quad S^3 \diamond o$$

This is what happens in the relation of a signifier to another signifier, namely, that it is the subject that is represented there, which here will never know. Once any signifier whatsoever in the chain can be put into relation with what is nevertheless only an object, namely, what is fabricated in this relationship to *surplus enjoying*, in this something that is able through the opening of the operation of the organism to take on the figure of these vanishing entities that I have already given the list of, which go from the breast to dejections and from the voice to the look, the fabrication of the discourse of the renunciation of enjoyment. The mainspring of this fabrication is the following, it is that around them can be produced the surplus enjoying. That assuredly if already in connection with Pascal's wager I told you that if there were only one life to be wagered to win beyond death, it would be well worth our while labouring enough in this one to know how to behave in the other. In this labour and its exchange as a wager with something, when we know that it is worth the trouble, there is found the mainspring of the fact that at the very foundation of the idea handled by Pascal it appears with the extraordinary blindness of someone who is himself at the beginning of a period of unleashing of the function of the market and its correlative the one that introduced scientific discourse. Let us not forget that he is also the one who wanted, at the most extreme moments of his retreat and his conversion, to inaugurate in Paris a *Compagnie des Omnibus Parisienne*. If this Pascal, who does not know what he is saying when he speaks about a happy life, we have the incarnation of it, what else is graspable under the term of happy if not precisely this function incarnated in the surplus enjoying? And moreover we have no need to wager on the beyond to know what it is worth.

(17) Where the surplus enjoying is unveiled under a naked form has a name. It is called perversion. And that is why a holy woman has a perverse son. There is no need for the beyond to see what happens in the transmission from one to the other in terms of the operation of an essential discourse.

$$\frac{\$}{\circ} \diamond (\$ \diamond (\$ \diamond \circ))$$

Here then is opened the figure, the schema of what allows it to be conceived how it is around the phantasy, namely, of the relationship of the reiteration of the signifier that represents the subject in relation to itself that there is played out what is involved in the production of \circ . But inversely, by this fact, their relationship takes on consistency and it is from this that there is produced here something that is no longer either subject nor object, but that is called phantasy. Henceforth, the other signifiers can, by linking up, articulating and at the same time here, freezing in the effect of meaning, introduce this effect of metonymy which means that this subject, whatever he may be, whether it is in the sentence, at the level of the child of "A child is being beaten, *On bat un enfant*", at the level of the *on*, something equivalent solders this subject and makes of him this solidary being that in the discourse we have the weakness to give the image of as an omnivalent image, as if there could be a subject of all signifiers.

If there is something that, through the analytic rule, can be sufficient relaxed in this chain for there to be produced these revelatory effects, what sense, what accent should we give to it so that it can have some import? The ideal no doubt is that this mythical [critical?] "I speak" which will bring about in analytic experience the effect, the image of the appearance of the truth.

It is here precisely that it must be understood that this emitted truth is suspended there, caught between two registers, those whose two limits I posed precisely in the two terms that figure in the title of my seminar this year. Because this *either*, a reference to the field where the discourse of the subject would take on its consistency, namely, to the field of the Other that I defined as this locus where every discourse at least posits itself in order to be able to offer itself to what is or not its refutation. That it can demonstrate, and in the most simple form – you will excuse me for not having the time to do it today – that the problem of whether or not there is a God who

guarantees as for Descartes the field of truth is completely uncalled for. It is enough for us that it can be demonstrated that in the field of the Other there is no possibility of a complete consistency of discourse and this I hope the next time to be able to articulate for you precisely in function of the existence of the subject.

I already wrote it out once very rapidly on the board. It is a proof that is very easy to find in the first chapter of what is called set theory. But again it would be necessary, at least for part of the listeners here, to show why it is relevant to introduce into the elucidation of the function of a discourse such as ours, we analysts, in some way (18) extract it from a logic that it would be quite wrong to believe is a way of excluding it into the neighbouring amphitheatre to call it mathematical logic. If nowhere in the Other there can be assured in any way the consistency of what is called the truth, where then is it unless this function of the \circ corresponds to it. Moreover, have I not already on some other occasion expressed what is involved in the cry of the truth. "*Me, the truth, I wrote, I speak, and I am pure articulation expressed to your embarrassment*". What the truth can say is there to move us. But what the one who is suffering says by being this truth, ought to know that its cry is only a mute cry, a cry into the void, a cry that already at one time I illustrated by the celebrated engraving of Münch, because at this level nothing else can correspond to it in the Other than what gives it its consistency and in the naïve faith that it is like me, namely, that it is its true support, namely, its fabrication as \circ -object. Faced with it, there is nothing but that, than *the additional one (l'un en plus)* among so many others, that can in no way correspond to this cry of the truth except that it is very precisely its equivalent, non-enjoyment, misery, distress and solitude. It is the counterpart of this \circ , of this surplus enjoying that gives its coherence to the subject *qua ego*.

There is nothing else, unless for today to want to leave you on something that makes one smile a little. I take up again the words that, in *Ecclesiastes*, an old king who did not see the contradiction between being the king of wisdom and having a harem, who tells you, "All is vanity no doubt, enjoy the woman that you love, namely, make a ring of this hollow, of this void at the centre of your being, there is no neighbour if not this very hollow in you, it is the emptiness of yourself". But in this relationship undoubtedly guaranteed only by the figure that allowed Freud no doubt to hold on throughout this whole perilous path and to allow us to clarify the relationships which,

in this myth, would otherwise not be tolerable, the divine law that leaves in its entire primitiveness this enjoyment between man and woman of which it must be said:

“Give her what you do not have, because what can unite you to her, is only enjoyment”. It is on this point that in the style of a simple, total, religious riddle, of one that is only approached in the Cabbala that I will discharge you today.

Seminar 2: Wednesday 20 November 1968

The last time, which was a premiere, I made reference to Marx in a relation that, in a first moment, I presented as homologous, with all that this term involves by way of reservations. I introduced alongside, let us say, surplus value what is called, in the original tongue – not that this notion of course was being named for the first time but discovered in its essential function – *Mehrwert*. I wrote it because God knows what would happen if I only pronounced it, in front of what I have here as an audience, and especially psychoanalysts when they are recruited from among those that are described as being by nature or heredity, double agents. Soon people will be telling me that it is the sour mother (*mère verte*), that I am rediscovering familiar paths. It is with this, with my “it speaks”, people reintegrate the supposedly obstinate desire of the subject to find himself again nice and warm in the maternal womb. So then to this surplus value, I hooked on, I superimposed, I plastered on the other side the notion of *surplus enjoying*. It is said like that in the original tongue. It was said the last time for the first time, namely, in French. To restore it to the tongue from which the inspiration for it came to me, I would call it, provided no German scholar in this assembly does not oppose it *Merhlust*.

Naturally, I did not bring forward this operation without making a discreet reference, in the way I sometimes do, an allusive one, a discreet allusive reference to the one, why not, whose researches and thinking led me to it, namely, Althusser. Naturally, as usual, in the hours that followed, this created some stir in the cafes where people gather, and how flattered I am at it, even delighted, to chew the fat over what has been said here. In truth, what can be said on this occasion, and what I do not deny since it

was on this plane that I introduced my remarks the last time, namely, this factor, the *pouvellicant* or *pouvellicatoir* factor, whatever you want to call it, of structuralism. I had precisely made an allusion to the fact that according to the last echoes I had Althusser was not very comfortable in it. I simply recalled that, whatever he may avow or renounce in structuralism, it seems indeed to whoever reads it that his discourse makes a structuralist of Marx and very precisely because he underlines his seriousness.

It is to this that I would like to come back since moreover, what I am indicating, is that one would be wrong to see in some mood or other that what is essential here is to (20) rally behind a flag. Namely, that as I already underlined on other occasions, what I am stating at least for myself when we are dealing with structure, I already said, is to be taken in the sense of what is most real, the real itself. And when I said at the time when here, on the board, I drew, indeed manipulated some of these schemas with which there is illustrated what is called topology, I already underlined that in this case, it was in no way a kind of metaphor. Either one thing or the other. Either what we are talking about has no kind of existence, or, if the subject has one, I mean as we are articulating it, well then it is exactly constructed like that, namely, it is constructed like these things that I wrote on the board, on the paper I use. On condition of course that you know that this little image which is all that one can put down, in effect, to represent it, on a page, that this little image obviously is only there to image for you certain connections that cannot be imagined but on the other hand can perfectly well be written. The structure is therefore real. It is determined by convergence towards an impossibility, in general. But that is how it is and it is because of this that it is real. So then there should almost be no need to talk about structure. If here I am speaking about it, if I speak about structure, if I speak about it again today, it is because I am forced to do so. Because of the chit-chat in the cafes! But I ought not to need to talk about it because I say it. What I say sets up the structure because it aims, as I said the last time, it aims at the cause of the discourse itself. Implicitly, and like each and every one who teaches, by wanting to fulfill this function, I defy in principle that I can be refuted by a discourse that justifies discourse differently to the way I have just said it. I am repeating it for those who are deaf. Namely, what it aims at is the cause of discourse itself. That someone should justify discourse in a different way as an expression of or as a relationship to a content for which a form is invented, that's up

to him! But I remark then that it is unthinkable, with this position, that you should inscribe yourself under any heading whatsoever in the practice of psychoanalysis. I mean even not as charlatanism. You should understand that the question is whether the psychoanalysis I am indicating here exists. It is precisely this that is at stake.

But on the other hand there is something by which it indisputably affirms itself. It is the symptom of the point in time that we have come to, let us say, in this provisional word that I would call, like that, civilisation. I am not joking! I am not talking about culture. That is vaster! It is moreover a question of convention. We will try to situate culture in the current usage that is made of this term at a certain level that we will call commercial.

Good! Let us come back to my discourse.

To employ a metaphor here that I already used on several occasions to make you (21) sense what I mean by a discourse that is valid, I would compare it to a scissors' cut in this material that I talk about when I talk about the real of a subject. It is through this scissors' cut in what is called structure, in the way that this happens, that it is revealed for what it is. If one makes the scissors' cut somewhere, relationships change in such a way that what is not seen before is seen afterwards.

This is what I illustrated by saying that it is not a metaphor, in recalling to you that the scissors' cut in the Moebius strip makes a strip that no longer has anything to do with what it was previously. To take the next step, one could even say that in grasping this transformation, one perceives that it is the scissors' cut that, in itself, is the whole strip, I mean, as long as it is, in so far as it is, a Moebius strip.

This is a way of speaking about the slightest metaphor. In other words, in principle, whether you call it structuralist or not, let us say that it is not worth the trouble to talk about anything except the real in which discourse itself has consequences. Whether you call that structuralism or not, it is what I called the last time the condition of seriousness. It is particularly required in a technique whose pretension it is that discourse has consequences in it since the patient only submits himself in an artificially defined fashion to a certain discourse regulated in order that there should

be consequences. Nothing prevails against these remarks, not even those that one sees displayed in books whose text is otherwise marked by this discourse itself, by saying that I neglect the energetic dimension for example. Things like that, I let pass. I let them pass when it is a matter of polemical responses. But here, we are at the heart of the subject since, as I pointed out the last time, for this exalted reference – especially for those who do not even know what it means – to energetics, I substituted a reference that, in our time, one would have difficulty in suggesting is less materialist, a reference to the economy, the political economy. But let us not disdain energetics on this occasion. For it to have a reference to our field, if we apply what I have just said, it is necessary that the discourse should have consequences in it.

Well then, precisely, it has! I am speaking about real energetics, about where it is situated in science, about physics. I even at one time, and well before these laughable objections were published, put into lectures that those involved were perfectly able to hear because they made use of them afterwards in their own lectures. I precisely underlined that energetics is not even conceivable otherwise than as a consequence of discourse. It is not because it is physics that it is not clear, that, without a signifying mapping out of the dimensions and the levels with respect to which there can be estimated, evaluated the initial function of the labour, naturally in the sense of (22) physics, there is not even the probability of beginning to formulate what is called the principle of all energetics in the literal sense of this term, namely, the reference to a constant, which is precisely what one calls energy, in relation to a closed system which is another essential hypothesis. That one can make with that a physics and one that functions, is indeed the proof of what is involved in a discourse that has consequences.

This implies at the same time that physics implies the existence of a physicist and, what is more, not just anyone whatsoever, a physicist who has a correct discourse in the sense that I have articulated it. Namely, a discourse that is worth the trouble saying and is not simply something that is all of a flutter; which is what energetics becomes when it is applied to a usage as delusional and hazy as that made of the notion of libido when people see in it what is called “a life drive”. In short, to say that physics does not labour without the physicist is not, since I hope there will not be found any understanding here to formulate the objection – which would be rather

ridiculous with what I have just stated – that this is an idealist postulate. Because what I am in the process of saying, is that it is the discourse of physics that determines the physicist and not the contrary. Namely, that there were never real physicists until this discourse prevailed. Such is the sense that I give to an acceptable discourse in what I am calling science.

Only there you are. Inevitably, people imagine that the realistic argument is to make an allusion to the fact that, whether we are there or not, we and our science, as if our science were ours, and if we were not determined by it, well then people say nature is always there. I absolutely do not dispute it. Nature is there. The way physics distinguishes itself from nature is that physics is worth saying something about, that discourse has consequences in it. In nature, as everyone knows – and that is even why it is so loved – no discourse has any at all! This is what differentiates nature from physics. To be a philosopher of nature was never taken at any period as a certificate of materialism, for example, nor of scienticity.

But let us take things up again, because that is not where we are. If physics does indeed give us a model of a discourse that is worthwhile, the necessities of our discourse ought to be taken at a higher level. Every discourse presents itself as heavy with consequences, but ones that are obscure. Nothing of what we say, in principle, fails to imply some. Nevertheless we do not know which. We notice in language – for it is at the level of language that I will take things up, and to clearly mark the limits – a syntax that is incarnated by a great number of tongues that, for want of boldness, are called positive tongues. Because I am there, and because I have just made a remark about nature that, I think, does not at all seem to you irrelevant, but (23) why, why should we inconvenience ourselves and not call them natural tongues? One would see better in this way what concerns linguistics and what allows it to be situated in the discourse of science. It is quite clear that even vis-à-vis language – whatever prevalence we may accord to it because we forget it as a natural reality – every scientific discourse about the tongue is presented by a reduction of its material. A functioning is highlighted in which consequences are grasped. I would say more, in which there is grasped the very notion of consequence with its varieties of necessary or contingent for example. There is carried out then a discursive split and this is what allows there to be given its whole value to the fact that I first of all affirm that there is

no meta-language, which is true in the field of natural language. But why do you carry out this reduction of the material? I have just told you. It is to highlight a functioning in which consequences are grasped, and once you grasp consequences, you articulate them in something that you have the right to consider as meta-language, except for the fact that this “meta” can only create a confusion. And that this is why I would prefer what gives rise to the detaching in discourse of what must be called by its name, logic – I am indicating here nothing more – always conditioned by nothing other than by a reduction of material. And I illustrate here what I mean.

Reduction of material means that logic begins at this precise date in history when, for certain elements of language as functioning in their natural syntax, someone who understands it, who inaugurates logic, substitutes for certain of these elements a simple letter. It is starting from the moment when with, “if this, then that” you introduce an A or a B that logic begins. And it is only starting from there that in language you are able, about the use of this A and of this B, to pose a certain number of axioms and laws of discussion that will merit the title of being articulated as meta- or if you prefer para-language. So then no more than physics extends, like the goodness of God, to the whole of nature, does logic circumscribe the whole of language.

It nevertheless remains, as I have said, that either it is a delusion, absurd folly to dwell on it – this indeed in effect is the whole appearance that one has of it in these publications, most of them – to dwell on psychoanalysis, or what it states is that everything that you are, to be understood as up to now, as a sentient being – I did not say simply as a thinking being, even though after all there is no reason to have any repugnance for this term; is the fact of thinking the privilege of intellectualistic intellectuals who, as everyone knows, are the poison of this nether world, of this nether psychoanalytic world I mean – everything that you are as a sentient being falls under the influence of the consequences of discourse. Even your death, I mean the (24) quaint idea that you may have of it, is not separable from the fact that you can say it, and I mean by that not just to say it naively. Even the idea that I call quaint, because in effect it does not have any great weight for you, that you have of your death is not separable from the maximal discourse that you may weave about it. This indeed is the reason why the feeling that you have of it is nothing but quaint. I would

even say that naively, you cannot begin to say it. Because what I am alluding to, is not at all to the fact that primitive people are naïve and that is why they speak about it in such a funny way. That for them it is always a device, a poisoning, a spell that has been cast, a gadget that is not labouring somewhere, in short an accident, this does not at all prove that they speak about it naively. Do you find that that is naïve! It is quite the contrary. But it is precisely for that reason that they also fall under this law. The feeling they have about their death is not separable from what they can say about it, which was what had to be proved.

There is a person, like that, earlier, among those who might instruct themselves a little bit here and get rid of their nonsense, who left because she finds no doubt that what I am saying are banalities. Apparently it is necessary to say them; otherwise why would I take the trouble, after all I have just said, about the fact that a discourse has consequences or not. It had in any case as a consequence this leaving, which serves as a signal. This indeed is why it is essential that in psychoanalysis we should have some minds formed in what is called - I do not know why - "mathematical logic", like that, through an old constraint, as if there were any other. It is quite simply logic. It happens that it has interested mathematics. This is all that distinguishes it from Aristotelian logic that very obviously did not interest mathematics. It is a progress for logic that it interests mathematics, yes! This mathematical logic, to call things by their name, is altogether essential for your existence; whether you know it or whether you do not know it. It is precisely because you do not know very much about it that things happen that stir things up from time to time, very recent things. People are waiting for me to talk about them, but I will speak about them, I will speak about them! It all depends on the time that I am going to spend in unfolding what I prepared for you today and I would like to have a little point, like that, to give you before leaving you. But it is not sure, because I never know too well. What I bring you is never absolutely measured out.

That is not where the question is. Whether you know it or whether you do not know it, the bizarre question is that obviously I have just alluded to the fact, since I told you that whether you knew it or whether you did not know it, whether it has always been true that mathematical logic has consequences as regards your existence as a subject, (25) which I have just said are there whether you know it or whether you do not know

it. Because then the question is posed, of how it could happen before the logic that is called mathematical came to birth? It is the question of the existence of God. I have already remarked it but I repeat – one cannot repeat oneself too much – was mathematical logic already there, in the divine brainbox, before in your existence as a subject, which would have thus been conditioned from that moment on, you were already affected by it?

It is a problem that has all its importance because it is around this that there takes effect this advance that a discourse has consequences. Namely, that something close to the effects of discourse was required for there to be born that of mathematical logic. And that in any case, even if something could already represent in an existence of a subject something that retroactively we can attach to some facts in this existence of the discourse of logic, it is quite clear, it ought to be firmly held that they are not the same consequences as since this discourse, I mean that of mathematical logic, has been put forward.

Here there is situated the necessary and the contingent in the discourse that is effectively held. This indeed is where I have trouble in seeing why the structural reference is supposed to overlook the dimension of history. It is simply a matter of knowing what one is talking about! History as it is included in historical materialism appears to me to conform strictly to structural requirements. Was surplus value there before abstract labour, I mean what this abstraction is separated out from, I mean as a social means, resulted from something that we will call – I am not guaranteeing the exactitude of the first word but I want to say a word that has weight – the absolutisation of the market. It is more than probable, and for a good reason which is that we have, for that, introduced the *surplus enjoying*. That one can consider that this absolutisation of the market is only a condition so that surplus value can appear in discourse. There was therefore required this thing that can with difficulty be separated from the development of certain effects of language, namely, the absolutisation of the market to the point that it encompasses labour itself, for surplus value to be defined in the fact that in paying with money or not, with money because we are in the market, for labour, its true price, as the function of exchange value is defined in the market, there is an unpaid value in what appears as the fruit of labour, in a use value, in what is the true price of this fruit. This unpaid labour, even though

paid in a correct fashion with respect to the consistency of the market, this, in the functioning of the capitalist subject, this unpaid labour is the surplus value. It is the fruit of the means of articulation that constitutes the capitalistic discourse from capitalist logic.

(26) No doubt, when it is articulated in this way this involves a claim about the *frustration* of the labourer. This involves a certain position of the "I" in the system, when this "I" is in the place of the worker, which is more and more generally the case. That this involves that is strange. This is what should be said. Because it is only the consequences of a perfectly well defined discourse, into which the labourer inscribes himself as a labourer, as "I". I said "I" here. Notice that I did not say subject although I spoke about the capitalist subject. I am going slowly because after all I will come back to it, we will look at it again – except I hope those who leave in the middle! – and you will see that it is not for nothing that I am saying here "subject", and that there I say "I". Because that will be found at a certain level, and at a level that must have functioned for a long time because it is that of my graph that I constructed more than ten years ago before an audience of donkeys. They still have not found where the "I" is on this graph! So then I will have to explain it for them. In order to explain it for them, I must prepare. We labour. It is work. Let us hope that I can tell you before the end how the labour, for us, at the level of this discourse, of the teacher, is situated. So then it is strange that this involves the idea of frustration, with the complaints which follow, the little reconstructions that are distinguished under the name of revolution. It is strange. It is interesting.

But I cannot from now on not articulate that at this precise point the conflictual dimension is introduced. It is difficult to designate it otherwise. I said that it was strange, and that it is interesting. That ought at least to encourage you to recognise it, no? I will designate it by this strange word, not less interesting but strange, which is the word truth. You know, the truth is not grasped just like that, huh! Of course I introduced it, like that, at one time, in its junction whose topology I tried to draw, in its junction with knowledge, because it is difficult to speak about anything whatsoever in psychoanalysis without introducing this junction. This clearly shows the prudence that is necessary because God knows what has come back to me in this connection in terms of the idiocies that are doing the rounds!

We are going to try to approach it a little bit more closely and to see how the capitalist reality does not have such bad relationships with science. It can function like that, in any case for some time yet, to all appearances. I would even say that it accommodates itself to it not badly at all. I am speaking about reality, am I not? I did not speak about the Real. I spoke about what is constructed about the capitalist subject, what is generated from the complaint fundamentally made about the recognition – otherwise the discourse of Marx has no sense – called surplus value. This is properly the scientific incidence into the order of something that is the order of the subject. Obviously, at a certain level this does not accommodate itself badly at all (27) to science. People send into the spatial orbs objects that are quite well shaped as well as being habitable. But it is not sure that at a closer level, at the one where there is generated revolution and the political forms that it generates, something is entirely resolved on the plane of this frustration that we have designated as being the level of a truth. No doubt the labourer is the sacred locus of this conflictual element which is the truth of the system. Namely, that a knowledge which holds up all the more perfectly because it is identical to its own perception of being, is torn apart somewhere. So then let us take this step that is allowed us by the fact that what is at stake without any doubt is the same substance. Let us feel what is involved in the structural stuff and let us make our scissors' cut. It is knowledge that is at stake. It is in relation to it, in its scientific form, that I have just given a prudent appreciation about what is involved in the relations, in the two realities that are opposed in our political world.

Knowledge, even though earlier I seemed to begin my discourse from it, knowledge is not labour. It is worth labouring at sometimes but you can get it without labour. Knowledge, at the extreme point, is what we call the price. The price is sometimes incarnated in money, but just as much in knowledge! It is worth money and more and more so. This is what ought to enlighten us! The price of what? It is clear, the price of the renunciation of enjoyment. Originally it is through this that we begin to know a little bit. No need to labour for that. It is because labour implies the renunciation of enjoyment that every renunciation of enjoyment is only accomplished through labour. An illumination like that comes to you provided you know how to hold yourself back, or to contain yourself, as I alluded to it the last time to define thinking.

A little moment of pause. You can perceive for example that the woman does not live on bread alone, but also on your castration, this for the males. After that you will be able to conduct your lives with more certainty. That is a use value, so it is!

Knowledge has nothing to do with labour. But in order that something should be clarified in this affair it is necessary that there should be a market, a market of knowledge that knowledge becomes merchandise. Now this is what is being precipitated. If you had no idea of it you ought at least to have a little suggestion of it, in seeing the form that things are taking, in seeing the atmosphere of a fair that for some time it took on in the University for example.

There are things like that, that I spoke about incidentally from other angles. There is no intellectual property, for example. That does not mean that there is not theft. It is even like that that it begins, property! All of this is very complicated. All of this only exists, of course, since lectures given abroad were paid for. I mean that one pays the foreigner. And even in France that is starting. It is from that moment that one can (28) discern what I once called, in an intimate circle, a heart lifting price (*prix haut-le-coeur*) to whoever shows himself to be specially in view in this sort of speculation. But all of this is only anecdote. Knowledge becomes a market not at all through the effect of corruption or the imbecility of men. You should understand for example that the Sorbonne, this has been known for a long time, is the elective place for this sort of negative quality, this sort of weakness. That was known everywhere throughout history. At the time of Rabelais, they were already swine. At the time of the Jansenists....it never fails, they are always on the right side; which means the wrong one! That is not what is new. That is not it! I looked for the root of what are ridiculously called the "events"; there was not the slightest event in this business. But I will explain this for you another time.

The very process by which science is unified in so far as it takes its node from a consequent discourse that reduces all knowledge to a single market, and this, for what we are questioning, is the nodal reference. It is starting from there that we can conceive that there is something there also that *qua* paid at its true price of knowledge according to the norms which are constituted from the market of science, is nevertheless obtained for nothing. This is what I called *surplus enjoying*. Starting

from knowledge, what is not new but is only revealed starting from the homogenisation of knowledge on the market, one finally sees that enjoyment is organised and can be established as *recherchée* and perverse. What is it then on this occasion that represents the discontent of civilisation as it is put? It is a *surplus enjoying* obtained from the renunciation of enjoyment, there being respected precisely the principle of the value of knowledge. Is knowledge a good [commodity?]? This is the question that is posed because its correlative is the following: *non licet omnibus* – as I already said – *adire Corythum*. Not everybody has for all that access to *surplus enjoying*.

What is there then in this affair paid or not? Labour as we have seen above. But in this register what is at stake? What I already highlighted earlier as regards what emerges in terms of conflict from the function of plus value puts us on the path, and this is what I already called the truth. The way in which each one suffers in his relationship to enjoyment in so far as he does not insert himself into it only through the function of *surplus enjoying*, this is the symptom, and the symptom in so far as it appears from the fact that there is no longer anything but an average social truth, an abstract truth. This is what results from the fact that a knowledge is always paid no doubt in accordance with its true price, but below the use value that this truth always generates for other than those who are in the truth. This is what the function of the *surplus enjoying*, of the *Mehrlust* involves, this *Mehrlust* that completely mocks us because we do not know where it is ensconced. Good! That is why your daughter is (29) mute, my dear children, namely, why in May we had our squalls. A great “speaking out, *prise de parole*” as someone who does not have in my field a negligible place expressed it. Taking the floor, I think that one would be wrong to give to this taking any homology with the taking of any particular Bastille. I would say rather taking tobacco or coke. The fact is that it was positively the truth that was manifested on this occasion. A collective truth, and which must be seen in the sense that the strike did not resonate at all badly with this truth, is precisely this sort of relationship that welds the collectivity to labour. It is even the same. Because one would be completely wrong to believe that a chap caught up in an assembly line works in it collectively in it. After all he is the one who does the work! In a strike, the collective truth of labour is manifested and what we have seen in May, was the strike of truth. There also the relationship to the truth was obvious. The truth was

displayed on the walls. Naturally, you should remember at this moment the relationship that happily I had highlighted 3 months before that the truth of stupidity (*vérité de la connerie*) does not fail to pose the question of the stupidity of truth. There are even stupidities that have been said about Lacan's discourse. It reproduced it like that – it was by chance, of course – almost textually. This obviously depends on the fact that things extracted from their context may well be truths but that does not prevent them being stupidities. This indeed is the reason why what I prefer is a discourse without words.

The strange thing was what one saw in terms of a passionate questioning, the one that emerged in the soul of what I would call – I think that you will see there being profiled his silhouette – the communist priest, the one whose goodness does not have a limit either in nature. Receiving, with him, moral propositions, you can count on it, these are things that come with age. There was one that I pinpointed forever with the title of *Mudjer Muddle*. This is the name I gave him, I thought it up myself. It evokes the crocodile and the mud that he bathes in and the fact that with a delicate tear he draws you into his well-meaning world. I met *Mudjer Muddle* on the pavement of Boulevard Saint-Germain. He told me that he was looking for Marxist theory and that he was inundated – by what? By the happiness that all of this bathed in. But it never occurred to him that happiness could come from the strike of the truth. Who would not be happy of course; from the weight that it weighs on us at every moment of our existence, we can be aware of what is involved by no longer having anything but a collective relationship with it.

So then I do not depreciate the fact that these truths displayed on the walls were sometimes stupid. As I told you no one has remarked that they are also in my discourse. That is because in mine they frighten people. But on the walls they frightened people also. And it is indeed from this that it comes, so many stupid things give rise to an unequalled fear. When collective truth emerges you know that any discourse can clear out.

(30) There you are. Things have returned to order a little. But it is smouldering. That is why there is an outflow of capital. Well then! Since I have taken the risk today of giving my interpretation of what are called the events, I would like to tell

you, you should not think for all that that this will stop the process. You would be wrong not to notice that, for the moment, there is even no question of it stopping, what I called the market of knowledge! And you yourselves are the ones who will act for it to become more and more established. The appearance in the reform of a notion like that of credits (*unités de valeur*), in the little bits of paper that you may be granted, the unit of value is that! It is the sign of what that knowledge is going more and more to become in this field, in the market that is called the University.

So then of course things ought to be followed very, very closely in order simply to map out there what is quite obvious that the truth may have its spasmodic functions here, but that this is not at all what will regulate for each of you your existence as a subject. Of what the truth, I reminded you of it the last time, the truth, my God, in a text, I was very kind, I made it state the most intelligent propositions that I could attribute to it. I loaned it what I say when I am not telling the truth. In other words, no discourse can tell the truth. The discourse that holds up, is the one that can hold up long enough without you needing to account for its truth. Wait there, with your backs to the wall, those who may present themselves to you by saying "psychoanalysis you know, huh, for our part we can say nothing about it." It is not the tone you require if you want to master the world by a value called knowledge. If a discourse is slipping away you have only one thing to do, call it to account. Why? In other words, a discourse that is not articulated to say something is a discourse of vanity.

You must not believe that the fact of saying that all is vanity which is what I left you on the last time, is something other here than a lure on which, as I told you, I wanted you to leave with your souls in pain until I took up this discourse again. And as regards what is involved in those who posit as a principle an essential vanity of all discourse, this is what the one I hold will have to take up with you again the next time.

Seminar 3: Wednesday 27 November 1968

We arrived the last time at a point that requires me to give you today some clarifications that I would call topological. It is not something new to what I am introducing here. But it is necessary for me to link it to what, precisely, I introduced this year under this form that designated the relation of knowledge to something, certainly more mysterious, more fundamental. To something that runs the danger of being taken to have the function of background as compared to the field of a form, while what is at stake is something quite different. I am talking about enjoyment (*jouissance*). It is only too obvious that enjoyment is of course the substance of everything we speak about in psychoanalysis. Through it we know well that it is not formless. Enjoyment has here the significance of allowing us to introduce this properly structural function, that of the *surplus enjoying*. This *surplus enjoying* appeared, in my last talk, in function of a homology with respect to the Marxist surplus value. Homology, clearly means – and I underlined it – that the relation is not one of analogy. It is indeed the same thing that is at stake. It is a matter of the same stuff in so far as what is at stake is the scissors' mark of discourse.

Am I making myself understood?

If it is quite true that what is involved here in mine – because everyone who has followed for a sufficient time what I am stating here sees what function this relation of *surplus enjoying* to surplus value turns around

– it is the function of the o-object. If in a certain sense I invented this o-object as one can say that the discourse of Marx invents, what does that mean, it is the lucky find of surplus value, this is not to say, of course, that it was not approached before my discourse. And it was called, but in a frankly inadequate way, as inadequate as was the definition of surplus value before the discourse of Marx made it appear in its rigour. But the important thing is not to underline this equivalence in the order of the importance of the discovery. The important thing is to pose the question of what we can think of the very fact of the discovery if, first of all, I define it as an effect of discourse. Because it is not a matter of theory in the sense that it might overlap something that at a given moment, may become apparent. The o-object is an effect of analytic discourse and, as such, what I say about it is only this very effect.

(32) Does this mean that it is only an artifice created by analytic discourse? This is the point that I designate, which is consistent with the foundation of the question as I am posing it, as regards the function of analysis. If the analyst himself were not this effect, I would say more, this symptom that results from a certain incidence in History, implying the transformation of the relationship of knowledge to this enigmatic foundation of enjoyment, of the relationship of knowledge in so far as it is determining for the position of the subject, there would be neither analytic discourse nor of course a revelation of the function of the o-object. But the question of artifice, as you see clearly, is modified, is suspended, finds its mediation in this fact that, what is discovered in an effect of discourse, already appeared as effect of discourse in History. That psychoanalysis in other words, only appears as a symptom in so far as a turning point of knowledge in History – I am not saying the history of knowledge – a turning point of the incidence of knowledge in History is already there that concentrated, as I might say, to offer us, to put this function within our reach. I am speaking about the one defined by the o-object. It is clear that no one, except one, my Italian translator whose modesty I will not offend,

because she missed the plane this morning and is not here, who very clearly perceived, some time ago, the identity of this function of surplus value and the o-object. Why were there not more? Why not more people to have stated it unless of course it may have happened that the matter was not communicated to me?

This is the strange thing. The strange thing that undoubtedly is tempered by grasping in real life as I do, it is my destiny, the difficulty of the progress of this analytic discourse, the resistance that grows in the very measure that it is pursued. And nevertheless is it not curious, since moreover here I have a testimony that after all takes its value because it comes from someone who is of the youngest generation, is it not curious to see, through an effect, assuredly, that I will not designate as being that of my discourse, but as being that of the growing difficulty that is generated from what I called this absolutisation of the market of knowledge, I am able to touch very frequently, much more easily, in the coming generation, is my exchange with those who after all, through a little experiment of calculation, I was able to give the average age of, let us say with those who are 24 years old.

I would not go so far as to say that at 24 everyone is Lacanian! But surely that in a way, nothing of what I have been able to encounter over time, as they say, in terms of difficulties to make this discourse understood happens any longer, at least not at the same place as where I have to deal with someone or other – I am saying even being in no way a psychoanalyst – who approaches simply the problems of knowledge from their most modern angle and let us say has some openness to the domain of logic.... You want me to speak a little bit louder over there? You are making a little gesture, good, good.

(33) Also, since it is in this generation that people are beginning – I have echoes of it already, fruits, results – to study my *Ecrits*, and even beginning to produce what are called diplomas or theses, anyway,

putting them to the test of a university transmission, I was able recently, and I was not at all surprised by it, to note undoubtedly the difficulty that these young authors have in extracting from these *Ecrits* what can be called a formula that is acceptable and classifiable in the pigeonholes that are offered to them. Assuredly, what escapes them most is what is in it, what gives it its weight and essence, which is no doubt what grabs these readers that I am always so astonished to know are so numerous, is the dimension of work which, so precisely, is represented there. I mean that each one of them, each one of the *Ecrits* represents something that I had to displace, to push, to transport in the order of this dimension of resistance which is not at all of an individual order. It is simply, because the generations, already at the time when I began to speak, were recruited already at an older level, were in this slippery relationship to knowledge, in a word, formed, anyway, in such a style that nothing, in itself, was more difficult than to situate them at the level of this annunciating, denouncing experience that psychoanalysis is.

This indeed is why I am trying to articulate today, I am doing it in a certain hope that something can be connected up between what is offered to me in the attention of the younger generation and what is effectively presented as a discourse. Nevertheless, let there be no kind of expectation that this discourse can become an articulated profession of a position of distance with respect to what is really happening in the progress of analytic discourse.

What I am stating about the subject as itself an effect of discourse absolutely excludes that mine should become a system. While what constitutes its difficulty is to indicate, by its very process, how this discourse is itself determined by a subordination of the subject, of the psychoanalytic subject that I am here supporting with respect to what determines it and belongs to all knowledge. My position, as everyone knows, is identical at several points to what under the name of epistemology, poses a question that one could in a way always define

as follows: what is involved in the desire that sustains in the most hidden fashion the apparently most abstract discourse, let us say mathematical discourse?

Nevertheless, the difficulty is of a completely different order at the level where I have to place myself for the reason that, if what animates mathematical discourse is uncertain, it is clear that each of its operations is constructed to scupper, to elide and stitch up again, to suture this question at every instant. And remember what already appeared here four years ago about the function of the suture. While on the contrary, what is at stake in analytic discourse is to give its full (34) presence to this function of the subject. This reverses, on the contrary, the movement of reduction in logical discourse which is perpetually centred, and in a way all the more problematic in that it is in no way permitted to us to supply for what is a flaw, except by artifice, and by clearly indicating what we are doing at the moment when we allow ourselves to designate this lack, effect of significance (*signifiance*) of something that, claiming to signify it, cannot be, by definition, a signifier.

If we indicate the signifier of \emptyset - $S(\emptyset)$ - it is in a way to indicate this lack, and, as I articulated on several occasions, this lack in the signifier. What does that mean? What does this lack in the signifier represent if moreover we can admit that this lack is something specific to our misguided destiny? There we designate the lack. It has always been the same, and if there is something that puts us in relationship with History, it is to conceive the degree to which, for so much time, men have been able to protect themselves from it. But this is not the question that I have come to raise before you today; on the contrary, I told you, it is a matter of topology. If there is a formula that I repeated these days, these times with insistence, it is the one that roots the determination of the subject in the fact that a signifier represents it, represents it for another signifier.

This formula has the advantage of inserting into the simplest, the most reduced connection, that of a signifier 1, S_1 , to a signifier 2, S_2 , $S_1 \rightarrow S_2$. This is what we must start from in order not to lose, no longer be able to lose for a single instant the dependency of the subject. The relation of this signifier 1 to this signifier 2, all those – and it is not at all rare to be able to hope, from a certain moment – all those who have heard something about what is involved in logic, in what is properly involved in set theory, in what is called an ordered pair. Here I can only give an indication of it even if it entails giving a commentary on it later if a demand comes to me. This theoretical reference is nevertheless important to be attached here.

Nevertheless, what I am calling my discourse does not date from today or yesterday. I mean that as I announced the last time to you, there is something that our path leads us to the edge of. It is what is already constructed at the very level of experience and I would say of work, of the work that consists in bringing into my discourse, in an “I say” provoking those who want to overcome the obstacle that is encountered by the simple fact that this discourse, at one time, began in an institution that, as such is designed to suspend it. And I tried to situate, to construct this discourse in its fundamental relation to the relationship of knowledge in something that some of those who may have opened my book may have found at a certain page drawn under (35) the name of graph – ten years! Ten years already since this operation culminated in its coming to birth in the seminar of 1957-58 on *The formations of the unconscious*. And to clearly mark things in the real life situation that was in question, I would say that it is through a commentary on the *Witz*, on the witticism as Freud puts it, on the witticism then I am saying that this construction began. In truth I did not work directly at referring myself to this discourse itself – to take up here the point at which I left it the last time – but much more to something that, it has to be said, without being perfect and even without bearing witness to singular carelessness, has the importance nevertheless of bearing witness that at a particular date, namely, this

report, this summary was printed in the *Bulletin de Psychologie*. One can see in it that from that time, so prehistoric with respect to the emergence as such of the o-object that had not yet been designated – at this level which followed what I had done the previous year on object relations – that is not designated – but well and truly prefigured for whoever heard what followed – the o-object was only designated in the function of the metonymical object. Things are put in their place from that moment on and everyone can without referring to unpublished notes, find a testimony to it here in this report on *The formations of the unconscious* which covers in a first section the lectures of the 6th, 13th and 20th of November 1957. We find a first drawing which is presented as follows (figure 1).

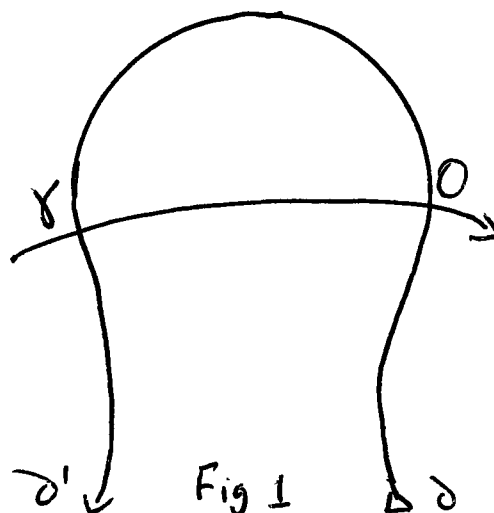

In the clearest fashion it is here at d that this line starts and culminates here at d' ; whether we put in d' or whether we do not put it in, it is clear that in looking at the drawing of this curve with this arrow at the end and this little pyramid at the start, there is no question of making it start here to go in the opposite sense. What matter, except for this detail, the testimony of the author of the summary retains its interest. Its interest above all in the fact to which he bears witness that if, since the matter has become banal, that this first outline of the graph has the function of inscribing somewhere what is involved in a unit of the signifying chain in so far as it only finds its completion where it cuts again the intention at the future perfect that determines it. Namely, that, if something is established which is the meaning (*le vouloir dire*),

(36) let us say that what is unfolded from the discourse will only be achieved by rejoining it, in other words only takes on its full import in the way designated here, namely, retroactively. It is starting from there that one can carry out a first reading of this relation to an O taken as Other, the locus of the code, namely, of what must already be supposed as a treasury of language in order for there to be extracted from it, under the seal of the intention, these elements that have been inscribed one after the other in order to unfold from there in the form of a series S_1, S_2, S_3 , in other words a sentence that is only completed when something is firmly realised in it.

What would be more natural, if only in a didactic fashion, than to have articulated then – and after all, why would I myself not tremble now when I think how long this march was – to have let myself then slip into such weakness. Thank God there is nothing of the kind. I read from the pen of the scribe of that time who, despite his carelessness nevertheless very well retained here what is essential: *“Our schema represents not the signifier and the signified, but two states of the signifier”*. The circuit, I am not going to repeat it for you in the way he states it because he states it wrongly, but it is obviously the following; the circuit designated as: $\partial O \chi \partial$, *“represents the signifying chain in so far as it remains permeable to the effects of metaphor and metonymy, that is why we hold it to be constituted at the level of phonemes. The second line – it is the one you see drawn here whatever confusion is introduced into it by a bad mapping out on a schema that is poorly produced here, I am telling you simply almost at the level of literal designations – represents the circle of the discourse, common discourse constituted by semantemes that, of course, do not correspond in a univocal way to something of the signified but are defined by their use”*. You clearly sense the degree to which this, at the level at which I am constructing it, can be conditioned by the necessity of putting in place – even though it still had to be seen that this was the most evident access – of putting in place the *formation of the unconscious* in so far as it can produce on this occasion the *Witz*, what is involved in

the formation of the word "*famillionairely*". Is it not obvious that this can only be produced in so far as there can be re-cut in a precise structurally definable interference something that operates at the level of phonemes with something that belongs to the circle of discourse, of the most common discourse? When Hirsch Hyacinth – and it is essential here that it is not recounted here by Heinrich Heine the other H. H. – when Hirsch Hyacinth speaking about Solomon Rothschild says that he received him in 'a quite familiar way', familiarly comes into the circle of discourse, coming to say that he received him *famillionairely*. Namely, that there is inscribed there, that he brings into it supplementary phonemes, that he produces this priceless formula which does not fail to have an import, for anyone at all, this familiarity that, as Freud expresses it somewhere, does not fail to have (37) an aftertaste of millions. This is not a witticism, nobody will laugh if you express it in that way; if it is expressed, if it appears, if it makes a breakthrough in the form of *famillionairely*, laughter will not fail to be produced.

Why after all will it not fail? It will not fail very precisely because of the fact that a subject is involved in it. When it is a matter of knowing where to place it, and very obviously we can only here – as Freud himself articulates it – notice that the subject is always functioning in a triple register. There is a witticism only with respect to the presence of a third. The witticism does not hold up, as such, between one interlocutor and another. Namely, at the moment when Hirsch Hyacinth tells the thing to his pal, the latter sees himself as being elsewhere, as being ready to tell it to another third person. And effectively this tripleness is maintained when this other third person repeats it. Because in order for it to have its effect on the one to whom he is going to tell it, it is precisely in so far as Hirsch Hyacinthe here remains alone and questions from his place what is involved for the one who recounts it to the one towards whom the message is referred, namely, the new listener. Where is the sensitive point of this "famillionaireness" if not, very precisely in the fact that will escape

each of those who transmit it. It is, namely, this novelty of the subject that I will not hesitate on this occasion to transplant into this field of the relation that I made intervene, that I introduced into our discourse under the term of capitalist subject. What is the function of each of those who pass between the links of the iron network that this constitutes and is insufficiently pinpointed by the notion of the exploitation of some men by others. All those who are not caught in these two extremes of the chain, what are they in this perspective if not employees? It is in so far precisely as each of the interlocutors feels himself, without knowing it, at the passage of this gentle fun of “famillionaireness”, involved as an employee or if you wish, as implicated in the tertiary sector, that this causes laughter.

I mean that it is not at all indifferent that it is Heinrich Heine who tells us that he got it from the mouth of Hirsch Hyacinth. But let us not forget that after all if Hirsch Hyacinth had existed, he is also the creation of Heinrich Heine. I already showed what the relations between Heinrich Heine and Baron Betty were, and that whoever is introduced from this angle into this something which appears to be only a point, a sally, a witticism, if he laughs, it is *qua* involved in this capture exercised, not just by something indifferent, a certain form of riches, certain modes of its incidence in a relation that is not simply that of social oppression, but of the involvement of every position of the subject in the knowledge that it commands.

But the interest of recalling the structure, in recalling that from this point on I distinguished here in a rigorous way the circle of discourse, (38) is indeed to show that in this way there was prepared the true function of what completes this first approximation of what is involved in discourse. Namely, that nothing can be articulated concerning the function of the subject if it does not to duplicate him with what seems, at another level, uniquely in virtue of the dimensions of paper, to be presented as a higher stage, but which is only there – one could just as

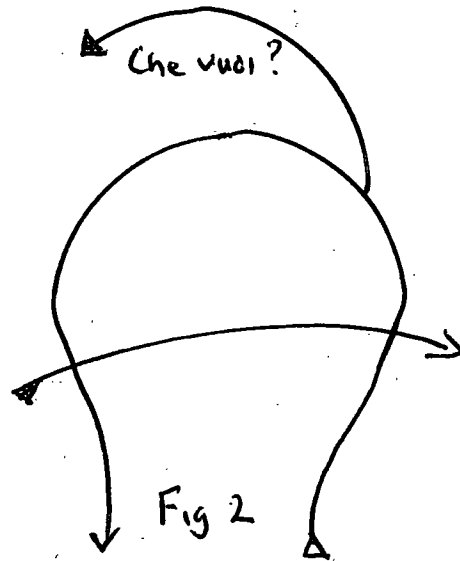

easily describe it upside down – in so far as it is precisely appended to this function of the big O which is the one that we have to question today.

We question it because there is no part of the discourse that, of itself, does not question it. I said in what well articulated way, so well highlighted by the analytic discourse itself in the way I introduced the hook as I might say, when I began to draw it in this way, stitching onto this simplified graph a question mark on top of it. I called it “*Che vuoi?*” in a reference to the *Diable amoureux*. What does it want? What does the Other want? I ask myself.(Figure 2). This duplicity of

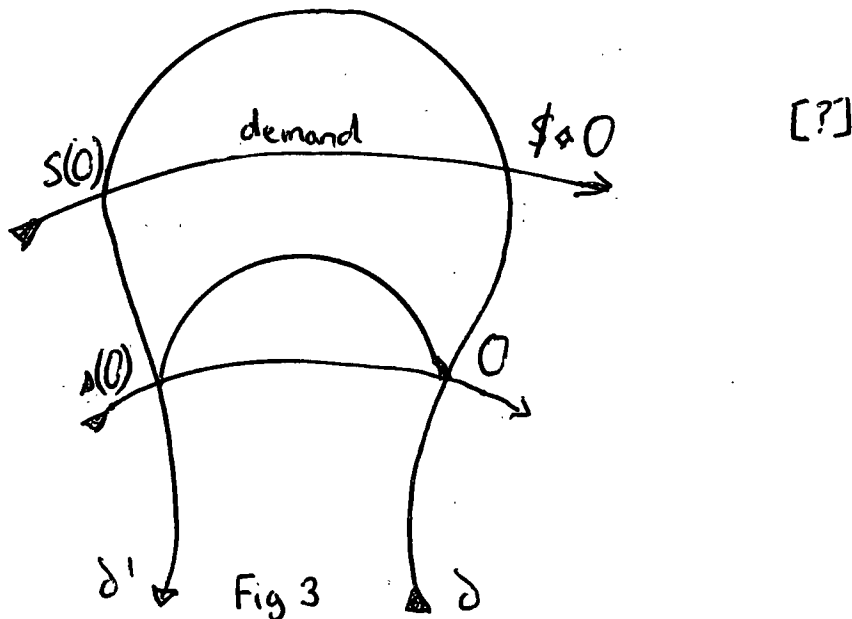

the relation to the Other which means we have here reduplicated what is presented as discourse or, let us say it in the more refined way, stating that is presented as demand, in a way that is perfectly well

indicated here, that this barred subject put into a conjunction, the one defined by what I will call provisionally the diamond shape, \diamond , with the demand D , articulated as such (Figure 3). This is moreover what this text and this account bear witness to, that already, it is well and truly as demand that this line is constituted.

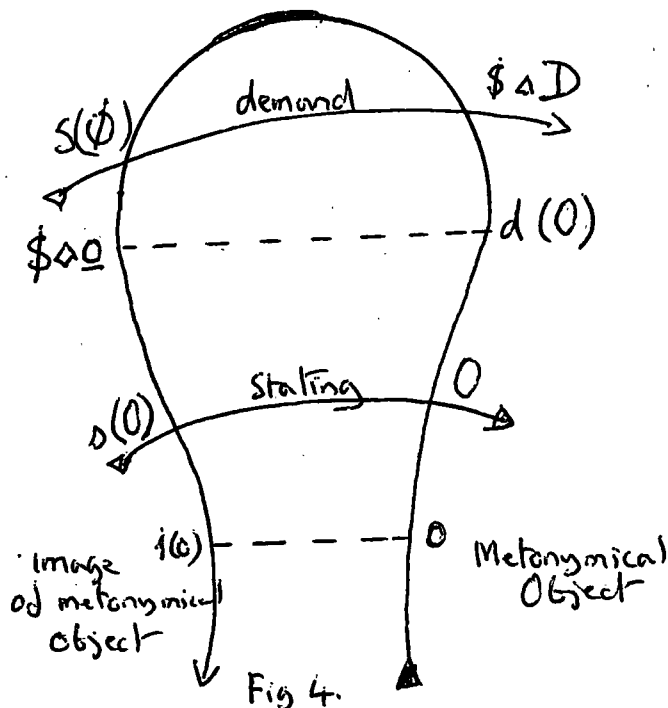

If here, what is contributed as homologous to the function $s(O)$, namely, to what is produced as subject-effect in the stating, here then, (39) the indication or the index $S(\emptyset)$ is now what we have not I would say to interpret for the first time, for I already did it in several forms, but to question again in the perspective that we are introducing today. We must therefore start again from the point that the subject is defined at the lowest point of what here is presented as a ladder, as being what a signifier represents for another signifier.

It is not simply through the superimposition of the function of the Imaginary on the Symbolic that I indicated here in my first schema the presence of the object then simply called metonymical object, to put it in correspondence with something which is its image and its reflection in e , in other words the ego, the image of o . The questioning about the desire of the Other is here the mainspring of Imaginary identification. It is apparently Imaginary, that is why I am putting it in red, but we are

going to see it also is articulated in a symbolic way. Here as you know there appeared for the first time the formula of phantasy, in the form of \$ diamond o. (Figure 4).

If from this moment on it is clearly indicated that the chain that retroverts this one, $\partial O \gamma \partial'$, is the chain of the signifier, it is indeed because there is here already contained the relation of the signifier 1, S_1 , to this minimal form that I called the ordered pair to which there is limited the statement of the signifier as being what represents a subject, a subject for what? For another signifier. This other signifier in this radical connection, is very precisely what represents knowledge, knowledge then, in the first articulation of what is involved in the function of the signifier in so far as it determines the subject. Knowledge is this opaque term in which, as I might say, the subject loses himself, or again is extinguished if you wish and this is what the notion that I underlined by using the term *fading* always represents. In this relation, in this subjective genesis, at the start, knowledge presents itself as this term in which the subject has extinguished itself; this is the sense of what Freud designated as *Urverdrängung*. This so-called (40) repression that is said, explicitly formulated, not to be such, but as being this kernel already beyond the reach of the subject while at the same time being knowledge. This is what the notion of *Urverdrängung* signifies in so far as it makes it possible for every signifying chain to connect up with it, implying this enigma, this veritable contradiction *in adjecto*, which the subject as unconscious is.

We have therefore sketched out here, from a very early or sufficiently early time in the articulation of this discourse that I find myself supporting in analytic experience, we have already put in question, interrogated, this question of what can be meant, at the level of discourse, of the formation of the unconscious, of the *Witz* on this occasion, who can say here: "I say". Because I precisely distinguished, and this from the origin of this discourse, what is involved in discourse and the word. And the key formula that I

inscribed this year at the first of these seminars, about what is involved in a discourse without words, the essence as I said of analytic theory, is indeed here to remind you that it is at this joint that there is going to be brought into play, this year, what we have to advance so that, in *From an Other to the other* who are we allowing to speak? It is not at all the word that is at stake here and I have not yet shown you, though already nevertheless I brought it into play by reminding you of the discourse that I attributed to this essentially ungraspable person that I called the Truth. If I made her say: "*Me, I speak.....*", it is indeed, as I underlined, because it is a matter of something different to what she says. I am indicating it here to mark that it is in the background, that she is waiting for us as regards what we have to say about the function of discourse. Let us take it up again now and observe that what is involved in the signifying chain – always the same, I am drawing it again – is the relationship of the signifier to another signifier.

Let us be satisfied, it is an artifice of presentation – I have no reason to hide it here – that allows me to avoid an introduction along the path of set theory and the remainder – if I had to do it, I would have to do it in some articulated way – the reminder of this fact that at the first step, this theory stumbles over a paradox, the one called Russell's paradox. Namely, what is to be done in a certain definition, that of sets, namely, what is closest to the signifying relation, a relation of connection. Nothing else is yet indicated in what the first definition of the function of signifier articulates, if not that it is the signifier 1, in a relationship that we can define as we wish, the simplest term will be that of belonging, the relationship of a signifier to another signifier. In this relationship we have said, it represents the subject S_1 S_2 . This so simple connection is enough to indicate to us if so many other traits did not indicate it to us, to indicate to us that from mathematical logic, as several linguists have perceived, it is set theory that finds itself most able to treat it. I am not saying to formalise it, but to treat this (41) connection. I remind you, for those who have heard it spoken of a little bit, that the first step that is met with is that with this single

condition of considering as a class – and this can even be proved – every element of such a connection in so far as one can write that it does not belong to itself, is going to involve a paradox. I repeat, I am only giving this introduction here to indicate the place, to develop it would make us rebound onto still more curious statements. Perhaps if we have the time or if we take it later on we will be able to do it.

I am going to proceed differently and only starting from my graph try to show you in a way, a formal one, what we are led to by the fact that we take the formula, the signifier represents the subject only for another signifier, that we take the elements that are offered us by the graph itself at the start, from here. It is S, a signifier that we are going to put here. If we take as other signifier this one constituted by O, if

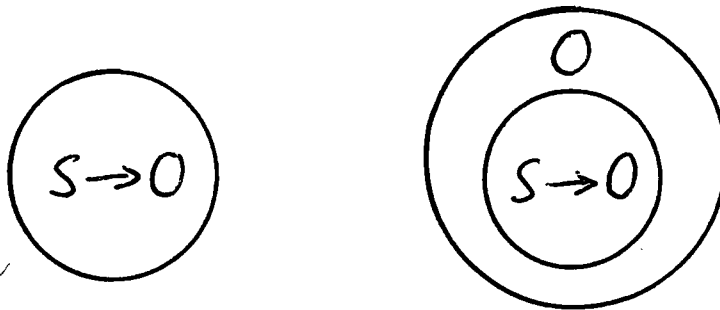

we called it first of all big O, the locus, the treasury of signifiers, do we not find ourselves in a position to question the following arrangement: what is involved in posing as signifier of the relation itself the same signifier that intervenes in the relation? In other words, if it is important, as I underlined, that in this definition of the signifier there only intervenes the alterity of the other signifier, what are we going to be led to? Can it be formalised in a way that leads somewhere, by pinpointing from this same signifier big O, the otherness of O? What is involved in the relation? This way of posing the question – I say it also to reassure those that it may disturb – is not at all foreign to what constitutes the starting point of a certain phylum of formalisation in mathematical logic. This, at this level, would require me to develop sufficiently the difference constituted by the definition of a set as compared to the class. The question is so well posed in mathematical logic that it is a point where it is indicated in this logic that, would to

heaven concerned us more closely, because the problems are resolved in it. Namely, that the class of sets that contain themselves – you see here at least indicated an example of it under the form of this inscription – this class does not exist. But we have something different to do than mathematical logic.

Our relationship to the Other is a more burning relationship. And the (42) fact of knowing whether what emerges from the simple fact of the demand that the Other contains already in a way, everything it is articulated around, if it were simply a question of discourse. In other words if there were a dialogue, that very precisely, at the end of last year, I proposed here that there is not this dialogue, if then this Other could be conceived of as a closed code, one whose key you would only have to press for the discourse to be established without fail, so that the discourse can be totalised in it. This is what, in this rudimentary fashion, and in a way in the margin of set theory, I am questioning. In place of this S_1 , I could have put a little b like that you would have noticed that it is a matter of b, a, ba . We are at the b, a, ba of the question. And from the ba you are going to see how it is dug out and this topologically. And this is how we have posed the question. It is clear that O in the ordered pair that constitutes this set is taken as identical to the O that designates it. We are therefore going to write as follows, the relationship of S with S in relation to big O , $S \rightarrow (S \rightarrow O)$.

I substitute for this O what this O is in so far as it is the signifier of the set constituted by the relationship of S to O , a relationship of ordered pair. This is quite usual in any development of a set theory whose very foundation is the fact that every element is supposed to be able to be the set itself. You see then what happens. Starting from this process we are going to have a series of – I do not know what the circles that I am drawing are, they helped us to make the set and its designation as such function – we have an indefinite repetition of S without ever being able at the end to stop the withdrawal, as I might say, of the big O .

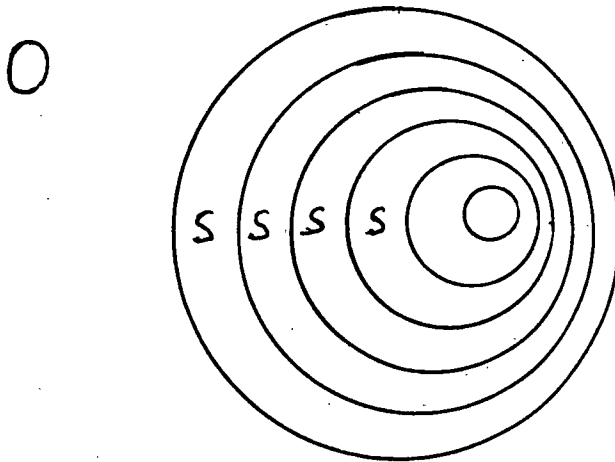

You must not get it into your head nevertheless that it is reduced, that it vanishes, as I might say spatially, that there is indicated here in any way something that constitutes whether it is of the order of an infinitesimal reduction of distance, or of some passage to the limit. It is only a matter of the ungraspability, even though it remains always (43) the same, of this O as such. This ungraspable character should not surprise us since we have made of this O the locus of the *Urverdrängung*. It allows us to see precisely that what I was questioning earlier, namely, what was involved in what is designated here as a circular drawing. It is in the measure that the O is multiplied in this way, simply from that fact, we can write it outside and inside, these circles are only indexing this identity. In other words, that this circle, pushed further in one direction, from which there emerges this notation of asymmetry will always in the final analysis join up with the starting circle. That this flight which ensures that it is in its own interior that an envelope finds its outside, this is what – you may or may not sense the kinship – what we have drawn in one of the previous years in the topological form of the projective plane and illustrated in a materialised fashion for the eye by the cross-cap. That the big O, as such, has in itself this flaw that one cannot know what it contains if it is not its own signifier, is the decisive question in which there is highlighted what is involved in the flaw of knowledge. To the degree that it is at the locus of the Other that there is appended the possibility of the subject in so far as it is formulated, it is most important to know that what guarantees it – namely, the locus of truth – is itself a locus that is holed.

In other words, what we already know about a fundamental experience that is not a random experience, an out of date production of priests, namely, the question *does God exist?* We perceive that this question only takes on its weight because precisely it depends on a more fundamental structure, namely, at the locus of knowledge can we say that in some way knowledge knows itself? It is always in this way that I tried, for those who listen to me, to displace this question that can only be the object of a wager about the existence of God, to displace it onto something that can be well and truly articulated. Namely, that however we support the function of knowledge, we are not able, it is a fact of experience, to support it except by articulating it in the signifier. Does knowledge know itself or is it gaping wide in its structure?

The circle that draws this shape that, more simply again, I mean O, for you to be able to find your bearings in it, I could - given this character that my drawing has of being a circle that rediscovers itself, but turned inside out, since what is most interior is connected up in order that a sense can be given to it as an index of the difficulty that is at stake - have referred myself, I said, to the Klein bottle, which I made enough drawings of here, I hope, for some people to remember it. What appears from it is what? It is that this structure, and in so far as you see, as we can give it some imaginary support - and this indeed is why we ought to be particularly sober - this structure is nothing other than the o-object. It is precisely because of that that the o-object is the hole that is designated in the Other as such, that is put in question for us in (44) its relation to the subject.

Because let us try now to hold onto to this subject where it is represented. Let us try to extract this S, this signifier that represents it from the set constituted by the ordered pair. It is here that it would be very simple for you to find yourself on familiar terrain, it is Russell's paradox. What are we doing here if not extracting from the set \mathcal{O} the signifiers that we can say do not contain themselves. It is enough -

and I will let you search in the first pages of any theory at all, naïve or not, of sets – it is enough for you to have consulted it to know that, in the same way as it is perfectly illustrated in the articulation of the sophism, the class of all the catalogues that do not contain themselves cannot in any way be situated in the form of a set for the good reason that it cannot in any way be recognised in the elements already inscribed of this set. It is distinct from it, I already went over this theme. It is well known. It is trivial. There is no way of inscribing in a set this something that you could extract from it by designating it as the set of elements that do not contain themselves.

I am not going to show it here on the board. It is enough simply that what results from simply posing the question of whether S is in O – in so far as contrary to it, it does not start from the fact, that as O, with respect to itself, it contains itself – by simply wanting to isolate it, you do not know, try it out, where to place it. If it is outside it is inside. If it is inside it is outside. In other words that in no way, for any discourse that posits itself as being essentially founded on the relationship of a signifier to another signifier, it is impossible to totalise it as discourse in the measure in which this is said and is posed as a question. The universe of discourse – I am speaking here not simply of the signifier, but of what is articulated as discourse – will always have to be extracted from whatever field whatsoever that pretends to total it.

In other words, that what you will see being produced inversely to this schema, is that, in the measure that you question yourself about the belonging to the set of any S whatsoever first of all posited in this relation, the S will be necessarily excluded from the small o. And that the next S you question – I said small o that was a mistake – the next S that you question is the one reproduced in the relation S(O) that I here showed, reproduced, will also leave it. They will all leave it indefinitely given the essence of what is essentially metonymical in the

continuity of the signifying chain. Namely, that every signifying element is extracted from any conceivable totality.

This, I apologise, to end, is no doubt a little difficult. But note that (45) in seeing this process being displayed with successive exits from envelopes that are never unfruitful, and not ever being able to be encompassed in it either, what is indicated, is that what is tangible in terms of the division of the subject emerges precisely from this point – that, in a spatial metaphor we call a hole, in so far as it is the structure of the cross-cap or of the Klein bottle – emerges precisely from this centre where the *o* is posited as absence.

This is enough to make you apprehend the continuation of the consequence that I will pursue as regards the graph and which may take on its full import as regards the place of analytic questioning between the chain of demand and the enunciating chain. Between the enunciating by which the subject only states himself as “he” and between what appeared not simply in terms of the demand, but of the relationship of the demand to the enunciating chain, as “I” and as “thou”. This will be the object of our next meeting.

Seminar 4: Wednesday 4 December 1968

Let us go to the heart of things because we are late and let us take things up by recalling on what, in short, were centred our last remarks about the Other, in short, about what I called *the big Other*. I ended by putting forward certain schemas, while sufficiently warning, I think, that they were not to be taken uniquely from their more or less fascinating appearance, but were to be referred to a logical articulation, the one properly made up of this relationship of a signifier to an Other signifier, $S_1 \rightarrow S_2$, that I tried to articulate in order to draw out its consequences by starting from the function, elaborated in set theory, of the ordered pair. At least it was on this logical foundation that I tried the last time to make you sense this something that has a point, a point around which there turns the interest - the interest for all I hope - the interest that it should be well articulated, that the Other, this big Other, O, in its function as I already approached it, the Other enclosed no knowledge that one can presume, let us say, will one day be absolute. You see, there I am pointing things towards the future while ordinarily I articulate towards the past, that this reference to the Other is the erroneous support of knowledge as already there. Good! So then here I am highlighting - because in a moment we are going to have to say it again - I am pointing up the use that I made of the function of the ordered pair. Because I had, my God, something that could be called the good luck, to receive from a hand that I regret is anonymous, a piece of paper posing the question of explaining myself perhaps a little more about this use of the ordered pair that, no doubt, to the author of

this note seemed a little precipitous, if not excessive. He perhaps does not all the same go that far – precipitous. I am not going to begin with that, but I take note to say that later then I will come back to it.

That the Other should be put in question, is extremely important for the continuation of our discourse. There is not in this statement, let us say first – this statement that the Other contains no knowledge that is either already there or to come, in an absolute status – there is not in this statement anything subversive.

I read something recently somewhere, at an ideal point that moreover will remain in its corner, as I might say, the term 'subversion of knowledge'. This term 'subversion of knowledge' was there, my God, advanced more or less under my patronage. I regret it because in truth I advanced absolutely nothing of the sort, and such slippages can only (47) be considered as very regrettable and enter into this sort of shoddy usage that can be made of fragments that are not even very well detached from my discourse. A screwing together again of terms that my discourse, precisely, never dreamt of bringing together to make them function on a market which would not be at all happy if it took the turn of being used for university colonisation. Why should knowledge be subverted because it cannot be absolute? This pretension, wherever it shows itself, or wherever it has shown itself, it must be said, has always been laughable. Laughable, precisely, we are here at the heart of our subject. I mean that this new start made in the witticism in so far as it provokes laughter, it provokes laughter, precisely, in short, in so far as it is properly attached to the fault inherent in knowledge.

If you will allow me a little parenthesis, I will recall, I will recall somewhere in – I thought I still had 25 minutes when I began, thank God, to signal that I wanted a taxi to be called, so that I did not find exactly the page of the first chapter of the third part of *Capital, The production of absolute surplus value* and chapter V on *Labour and its*

valorisation. It is there I believe that there are found a few pages, something that, make no mistake, I did not wait for the recent researches on the structuralism of Marx to pick out. I mean that this old volume that you see more or less coming apart in pieces, I remember the time when I read it in what was my transportation of that time, when I was 20 years old, namely, the Metro, when I was going to the hospital. And at that time, there was something that caught me and struck me, namely, how Marx, at the moment he introduces surplus value, he introduced a little more, a little surplus value, he did not introduce it, nor value, I am confusing you, but he introduces it and he introduces it after taking some time. Taking time like that, in a gentlemanly way, he allows the person involved, namely the capitalist, to speak. He allows him, in a way, to justify his position through what is then the theme. In any case the service that is rendered, in a way, by putting at the disposition of this man who only has, my God, his work, and at the very most a rudimentary instrument, his jointer, the lathe and the milling machine thanks to which he is going to be able to do marvels. An exchange of good and even loyal services. A whole discourse that Marx takes his time to develop, and what he signals, what struck me at that time, at the time of these good old readings is that he highlights there that the capitalist, a ghostly personage he is confronting, the capitalist laughs.

This is a feature that seems superfluous. It nevertheless seemed to me, it appeared from then on that this laughter is properly something that refers to what at that very moment Marx is unveiling, namely, what is involved in the essence of this surplus value. "My good apostle", he says to him, "keep talking. The service as you understand it, if you wish, of putting the means that you find you have at the disposition of (49) the one who can work. But what is at stake, is that this labour, this labour that you are going to pay for, that he can fabricate with this lathe and milling machine, you will not pay him any more for it than for what he was doing with his jointer that I evoked earlier. Namely, what he would have been able to guarantee by means of this jointer,

namely, his subsistence.” What is highlighted in passing, and of course not noted, about the conjunction of laughter with this relationship, this relationship here to a pleading that appears to be nothing but the most honest of discourses, is this relationship to this radically eluded function, whose proper relationship to this characteristic elision in so far as it properly constitutes the o-object, I already sufficiently indicated in our discourse

Here again, I am saying it because of not having been able to do so at the time when I began to construct the graph around the witticism, here is the fundamental relationship around which there still turns the shock, the forcing, a little more, a little less that I spoke about earlier, the conjuring trick, the hey presto that grabs our gut in the effect of the witticism. In short, the radical, essential function of the relation that is hidden in a certain relationship of production to work is indeed, as you see there as elsewhere, at another deeper point which is the one to which I am trying to lead you. Around *surplus enjoying* there is something like a fundamental *gag* that depends properly speaking on this joint into which we have to drive our wedge when what is at stake is this relationship that operates in the experience of the unconscious in its most general function. This is not to say – and here again I am going to take up something that may be used for risky formulae – this is not to say that there can in any way be a theory of the unconscious. In what I am doing, trust me, it is nothing of the kind that I am aiming at.

That there is a theory of psychoanalytic practice, undoubtedly, of the unconscious, no. Unless you want to pour in what is involved in this theory of psychoanalytic practice, which what? In the unconscious gives us what can be taken up in this field in the field of this practice, but nothing else. To speak about the theory of the unconscious, is really to open the door to this sort of ridiculous deviation that I am hoping to prevent. This is what has been displayed already, for long years, under the term of ‘applied psychoanalysis’, and has allowed all

sorts of abuse. To apply it precisely to what? In particular to the fine arts! In short, I do not want to insist any more, towards this form of tipping over or dumping on the edge of the psychoanalytic road, the one that ends up in a hole that I find dishonourable.

Let us take things up again. The Other only gives the stuff of the subject, or his topology or that through which the subject introduces a subversion certainly, but that is not only his own in the sense that I have pinpointed when I spoke about the subversion of the subject. The subversion of the subject with respect to what has been stated about it up to now, this is what is meant by this articulation in the title I put it into. But the subversion that is at stake is the one that the subject (50) introduces certainly, but that the Real sticks to, which in this perspective, is defined as the impossible. Now, there is no subject at the precise point where it interests us, except the subject of an assertion (*dire*). If I posit these two references, that to the Real and that to the assertion, it is to clearly mark that here that you may still vacillate and pose the question, for example, whether this is not what was always imagined about the subject. It is moreover also there that you have to grasp what the term subject states in so far as it is the effect, the dependent (*la dépendance*) of this assertion. There is no subject except of an assertion, this is what we have to correctly circumscribe in order never to detach the subject from it.

To say moreover that the Real is the impossible, is also to state that it is only the most extreme circumscribing of the assertion in so far as it is the possible that it introduces and not simply that it states. The flaw remains no doubt, for some people, that this subject would then be, in a way, a subject taking its worth from this discourse. That if would only be the deployment, a canker crossing in the middle of the world where the junction takes place that, all the same, brings this subject to life.

It is not just anything in things that makes a subject. This is where it is important to take things up again at the point where we do not tip over

into confusion in what we are saying - the confusion that would allow there to be restored this subject as thinking subject, any pathos whatsoever – about the signifier, I mean, through the signifier, does not of itself make a subject of this pathos. What this bathos defines is in every case, quite simply, what is called a fact. And it is here that there is situated the distance in which we have to question what our experience produces. Something different that goes much further than the being that speaks in so far as it is man that is at stake. More than one thing can suffer from the effect of the signifier, everything in the world that does not properly become a fact (*fait*) unless its signifier is articulated. Not ever, never, does any subject come unless the fact is said. Between these two frontiers is where we have to work. What cannot be said about the fact is designated in the assertion, by its lack, and that is the truth. That is why the truth always insinuates itself, but can be inscribed also in a perfectly calculated way where it simply has its place, between the lines. The substance of the truth is precisely what suffers from the signifier. That goes very far. What suffers from it in its nature. Let us say, when I say that this goes very far, this precisely goes very far in nature.

For a long time people seemed to accept what is called the spirit. It is an idea that got across in some little way. Moreover, nothing ever gets across as much as people think. In any case it got across a little because of the fact that it proves that there is never anything else at stake under the name of spirit than the signifier itself. Which obviously puts a lot of metaphysics out of sync. As regards the relationships of our effort to metaphysics, as regards what is involved in a putting in question that tends not to lose all the benefit of the (51) experience of metaphysics, something of it remains. Namely, the following which is indeed in a certain number of points, of areas more varied and better equipped than one might think at first approach and of very different qualities, it is a matter of knowing what 'structuralism' has to bring about. The question is raised in a collection that has just appeared, I got the first fruits of it, I do not

know whether it is in circulation: "*What is structuralism?*" which we owe to the summons addressed to some people by our friend François Wahl. I advise you not to miss it, it brings a certain number of questions up to date. But undoubtedly this means that it is rather important to mark our distinction from metaphysics. In truth, we have, on this point, marked something that it is not useless to state, that one must not believe too much in what advertises itself as disillusion. The disillusion of the spirit is not a complete triumph if elsewhere it sustains the superstition that would designate in an idealness of matter this very substance that one first puts into the spirit as impassible. I am calling it superstition because after all we know its genealogy. There is a tradition, the Jewish tradition curiously, in which one can indeed highlight what a certain transcendence of matter may be able to sketch out. What is stated in the scriptures, singularly unnoticed of course, but quite clear concerning the corporeality of God. These are things that we cannot develop today. It was a chapter of my seminar on *The name of the father*, which as you know [*the sign of a cross in the air*] I have definitively renounced, make no mistake. But in any case, this superstition described as materialist – one may well add popular, that changes nothing at all – deserves the share of love that everyone has for it, because it is indeed what has been most tolerant up to now of scientific thinking. But you must not believe that this will always last. It would be enough for scientific thinking to make people suffer a little in this quarter – and it is not unthinkable – for the tolerance in question not to last!

A sensitivity that is evoked already, my God, towards remarks like the ones I made one day before an honourable member of the Academy of Sciences of the USSR, that cosmonaut appears to me to be a bad name. Because in truth, nothing appeared to me less cosmic than the trajectory that was his support. A kind of disturbance, of agitation for such a gratuitous remark, my God, the properly speaking rash resistance, that it is not sure, after all – that is what I meant to say – that anything whatsoever, whether you call it God in the sense of the

Other, or Nature – it is not the same thing – but it is indeed to one of these two aspects that there must be reserved, attributed a prior knowledge of the Newtonian law for people to have been able properly speaking to talk about cosmos and cosmonaut. This is where one senses the amount of metaphysical ontology that continues to find shelter even in the most unexpected places.

(52) What is important for us is what justifies the rule that sets up psychoanalytic practice, quite stupidly, the one described as free association. Free means nothing other than dismissing (*congédiant*) the subject. To dismiss the subject is an operation, an operation that does not necessarily succeed; it is not always enough to tell somebody to quit for him to go. What justifies this rule is that the truth, precisely, is not said by a subject but is suffered. Let us pinpoint here what we will call phenomenological infatuation. I already picked out one of these tiny monuments that are displayed in a field where statements easily take on a patent of ignorance. *Essence de la manifestation*, is the title of a book very well received in the university field, and after all I have no reason to give the author because I am in the process of qualifying him as a conceited ass. The essence of his own manifestation, in any case, from this title as well as the power with which at a particular page there is articulated that there is one thing given to us as certain, it is that suffering, for its part, is nothing other than suffering. I know, in effect, this always does something to you when you are told that! It is enough to have a toothache and never to have read Freud to find that rather convincing. Here after all is why one may think incidentally – but there truly I think that I am also a little traditional – why one may give thanks for such blunders (*pas de clerics*), make no mistake, to call them that, to promote, as one might say, what is not to be said, for one to clearly mark the difference to what there has to truly be said. It is a little bit too much of a justification to give to error and that is why I am signalling in passing that in saying this, I do not completely adhere to it. But for that, my

God, I would have to re-establish what is involved in an apologia for sophists, and God knows where that would lead us.

In any case, the difference is the following. If what we are doing, we analysts, works, it is precisely because suffering is not suffering and to say what should be said one should say: "Suffering is a fact". This seems to be saying almost the same thing, but it is not at all the same, at least if you have well understood what I told you earlier about what a fact is. Rather let us be more modest; there is some suffering that is a fact, namely, that conceals an assertion. It is through this ambiguity that we refute that it is unsurpassable in its manifestation, that suffering can be a symptom, which means truth. I make the suffering speak, as I made the truth speak in a first approach – the effects of discourse must be tempered – I made them say, although in terms not modulated in the same tone for the one and the other, *I speak*. I am recalling it since I came back to it recently.

Let us try to be more rigorous as we advance. Suffering has its language and it is quite unfortunate that anybody at all can say it without knowing what he is saying. But, in any case, that is precisely (53) the trouble with all discourse. It is from the moment that it is rigorously stated, since true discourse is a discourse without words, as I wrote this year as a frontispiece, anyone could repeat it after what I have said to you. It no longer has any consequences. This is one of the risky aspects of the situation. Let us then leave suffering to one side and, as regards the truth, let us specify what we are going to have to focus on subsequently.

The truth, for its part, essentially speaks. It speaks "I" and you see defined there two extreme fields, the one in which the subject is only located by being the effect of the signifier, the one in which there is the pathos of the signifier without any mooring point yet being made in our discourse to the subject, the field of fact, and then what finally interests us and what was not even touched on anywhere but on Sinai,

namely, what speaks "I". On Sinai – I apologise, that just slipped out – I did not want to rush on to Sinai but since it has come out I have to justify why. Some time ago, just around this little flaw in my discourse called *The name of the father* and which remains gaping wide, I had begun to question the translation of a certain – I do not pronounce Hebrew well – "Haye". I think that this is pronounced "Hacher Haye", what the metaphysicians, the Greek thinkers translated by "I am the one who is". Naturally they had to have being. Only that does not mean that. There are middle terms, I am talking about people who say: "I am who am". That means nothing; it has the blessing of Rome. I pointed out, I believe that it should be understood as "I am what I am". In effect, this has all the same the value of a punch in the face. You asked me my name, I answer "I am what I am and go and screw yourself". This indeed is what the Jewish people have been doing ever since that time.

Since Sinai came out there in connection with the truth that speaks "I", it was Sinai that came out of me! But I had already thought about the question. I did not think I was going to speak to you about it today. But in any case since it has happened, let's go. I think it must be translated: "I am what I is" (*Je suis ce que je est*). That is why Sinai slipped out of me like that. It is to illustrate for you what I intend to question around what is involved in the 'I', in so far as the truth speaks 'I'. Naturally the rumour will spread in Paris, in the little cafes where all the gossip takes place that, like Pascal, I have chosen the God of Abraham, of Isaac and of Jacob. Let the souls from whatever quarter they are carried to welcome this news, put their emotion back in the drawer, the truth speaks "I" but the reciprocal is not true. Not everything that says "I" is the truth, without that where would we be?

This does not mean that these remarks are completely superfluous. Because you should clearly understand that in putting in question the function of the Other, and on the principle of its very topology, what I am disturbing -it is not too great a pretension, it is really the question

on the agenda - is properly what Pascal called the God of the (54) philosophers. Now to put that in question is not nothing! Because all the same, up to the present, he has had a hard life. And in the way that earlier I made an allusion to, he remains all the same quite present in a whole load of modes of transmission of this knowledge when I tell you that it is not at all subverted, even and much more, by putting in question this Other who is supposed to be able to totalise it. This is the sense of what I contributed the last time.

On the other hand, whether he told the truth or not, the other God that we should pay homage to our Pascal for having seen that he has strictly nothing to do with the other, the one who says "I am what I is". That this should have been said had some consequences. And I do not see why, even without seeing in it the slightest chance of truth, we should not enlighten ourselves from some of its consequences in order to know what is involved in the truth in so far as it speaks "I".

An interesting little thing, for example, is to notice that because the truth speaks "I" and because the response is given to it in our interpretation, for us psychoanalysts, it is an occasion for noting that interpretation is not simply our privilege. It is something I already spoke about at one time under the title of *Desire and its interpretation*. I pointed out that in putting the question around the "I" in this way, we ought, even if only to take a warning or indeed umbrage from it, to perceive that from then on, interpretation ought to be better circumscribed. Because prophetism is nothing else. To speak "I" in a certain furrow which is not that of our suffering is also interpretation. The destiny of the Other is suspended then, I would not say at the question, I would not say at my question, at the question posed by psychoanalytic experience. The drama is that whatever may be the fate this putting in question reserves for it, what the same experience demonstrates, is that it is from the desire of the Other that I am (*je suis*) - in the two marvellously homonymic senses of these two words in

French - that I follow (*je suis*) the trace. It is moreover precisely for that reason that I am interested in the destiny of the Other.

So then we have another quarter of an hour and the little note that I received goes as follows: “*Last Wednesday you related, without specifying, the ordered pair and a signifier represents the subject for another signifier, (S S)*”. That is quite true. That is why no doubt my correspondent put a bar underneath and underneath the bar “Why?” with a question mark. Underneath the why another bar, then marked by two big points or more exactly two little circles filled in in black. “*When the ordered pair is introduced into mathematics some force is necessary to create it.*” From this I recognise that the person who sent me this sheet knows what she is saying, namely, that she has at least a shadow, and probably more, of mathematical instruction. It is quite true. One begins by articulating (55) the function of what a set is and if one does not introduce into it, in effect, the function of the ordered pair by this sort of force that in logic is called an axiom, well then, there is nothing more to be done with it than what you have first defined as a set. In parenthesis, one adds on – either directly or indirectly – the set has two elements. “*The result of this force is to create one signifier that replaces the co-existence of two signifiers*”. This is quite correct. A second remark “*The ordered pair determines the two components, while in the formula a signifier represents the subject for another signifier, it would be astonishing for a subject to determine two signifiers.*” I only have a quarter of an hour and nevertheless I hope to have the time to clarify as it should be done, because it is not difficult, what I stated the last time, which proves that I did not state it adequately since someone, who as you can see is very serious, questions me in these terms.

$$\frac{S \rightarrow S}{\text{Why?}}$$

• •

I am therefore going to write on the board – whatever may be the inconvenience that was pointed out to me the last time about using the board which ought to be put there so that everyone can see what I am writing and that is not going to happen today given the difficulties that

conditioned my arriving late – this: $\langle S_1, S_2 \rangle$ At no time did I subsume the co-existence of two signifiers into one subject. If I introduce the ordered pair, as my interlocutor surely knows, I write for example the following: $\langle S_1 S_2 \rangle$, these two signs by a lucky chance find themselves to be the two pieces of my diamond shape when they are connected up, these two signs only serve on this occasion to very specifically write that this is an ordered pair. The translation in the form of a set, I mean articulated in the sense of the benefit expected from the force in question, is to translate this into a set whose two elements, the elements in a set being always themselves the set, you see there being repeated the bracket sign $\{(S_1), (S_1 S_2)\}$, the second element of this set $\{S_1, S_2\}$, an ordered pair is a set which has two elements, a set formed from the first element of the pair and a second set; they are then both one and the other subsets formed from the two elements of the ordered pair.

$$\{(S_1), (S_1, S_2)\}$$

Far from the subject here in any way subsuming the two signifiers in question, you see, I suppose, how easy it is to say that the signifier S_1 here does not stop representing the subject as my definition *the signifier represents a subject for another signifier* articulates it, while the second subset makes present what my correspondent call this “co-existence”, namely, in its broadest form this form of relation that one can call “knowledge”. The question that I am posing in this (56) connection and in the most radical form, whether a knowledge is conceivable that reunites this conjunction of two subsets in a single one, in such a way that they can be under the name of O, of the big O, identical to the conjunction as it is here articulated in a knowledge of the two signifiers in question.

That is why after having pinpointed by the signifier O a set of S means that I no longer need to put 1, 2.... because I substituted O for $\{S_1, S_2\}$. I questioned what followed from this as regards the topology of the Other and it is following this that I showed you in a way that was

certainly too imaged to be logically fully satisfying, but whose necessity as an image allowed me to tell you that this succession of circles involuting in an asymmetrical way, namely, now always in the measure of their apparently greater interiority the subsistence of O, but in so far as this imaging might suggest a topology which is the one thanks to which the smallest of these circles comes to be joined to the largest in this figure and the topology suggested by such an imaging, makes of it the index of the fact that big O, if we define it as possibly including itself, namely, having become absolute knowledge, has this singular consequence that what represents the subject is only inscribed there, is only manifested there in the form of an infinite repetition, as you have seen there being inscribed under the form of this S, big S, in the series of inner walls of a circle in which they are indefinitely inscribed.

S (S (S (

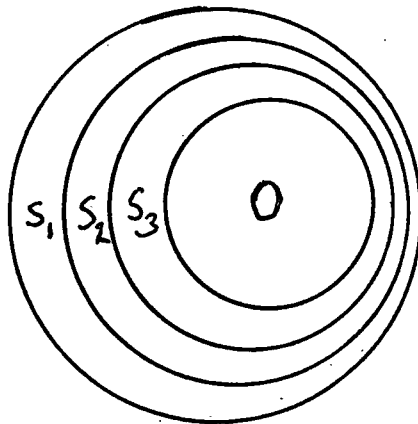

Thus the subject, by being inscribed only as an infinite repetition of itself, is inscribed there in such a way that it is very precisely excluded, and not by a relationship that is neither from the inside nor from the outside, from what is posited first of all as absolute knowledge. I mean that there is here something that takes into account, in the logical structure, what the Freudian theory implies as fundamental in the fact that originally the subject, with respect to what refers it to some fall of enjoyment, can only be manifested as repetition and unconscious repetition. It is therefore one of the limits around which there is articulated the link of maintaining the reference to absolute knowledge, to the *subject supposed to know*, as we call it in the transference with

this index of repetitive necessity that flows from it which is logically the little o-object, the little o-object in so far as here its index is (57) represented by these concentric circles.

On the other hand, what I ended on the last time is the other end of the questioning that we have to pose to big O, to big O in so far as we impose on it the condition of not containing itself. Big O only contains S_1, S_2, S_3 which are all distinct from what big O represents as signifier. Is it possible that in this other form the subject can be subsumed in a way that, without rejoining the set thus defined as universe of discourse, can be sure of remaining included in it? This is the point perhaps that I passed over a little quickly and that is why to end today I am coming back to it.

The definition of a set in so far as it joins elements, means that there is defined as a set every point to which several others are attached. I take point because there is no more tangible way of imaging the element as such. These points, for example, are with respect to this one, elements of a set that this fourth point can only image starting simply from the moment that we define it as element. Within the big Other then in which no O figures as an element, I can define the subject in this ultra-simple way in which it is precisely constituted, which seems to be exhaustive, by any signifier in so far as it is not an element of itself. Namely, that neither S_1 nor S_2 nor S_3 are signifiers like big O, that big O is the Other for all of them?

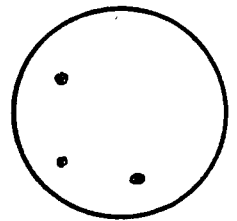

Am I going, as subject of the assertion – by simply putting forward this proposition that S, any signifier whatsoever, S_w meaning whatsoever, is not an element of itself – am I going to be thus able to assemble something which is this point here, namely, the set that connects all the signifiers thus defined, as I said, by an assertion (*dire*)? This is essential for you to remember for what follows. Because this “by an assertion” in other words, proposition, that around which we must first make the function of subject turn in order to grasp the flaw, because

whatever use you subsequently give to a statement, even its use of demand, is because of having marked what, as a simple assertion, it demonstrates as a flaw, that you can most correctly, in the flaw of the demand, circumscribe in the stating of the demand what is involved in the flaw of desire.

Structuralism everywhere is logic, which means, even at the level at which you may question desire – and God knows of course that there is more than one way – there are types that bell, there are types that (58) shout, there are types that dramatise! And it is worthwhile! Simply you will never know anything about what that means for the simple reason that desire cannot be said. Of the assertion it is only the ending and that is why this ending must first of all be circumscribed in a pure assertion, there where lay the apparatus of logic can demonstrate the flaw. Now it is clear that what here has the role of the second signifier, in essence – here I call them S alpha, S beta, S gamma – the second signifier, the subject in so far as it is the subset of all the signifiers in so far as they are not elements of themselves, in so far as O is not O, what can we say about it?

We have posited as condition – let us take here to be simple the letters you are already more used to, namely, X is not an element of X. In order that something may be inscribed under the rubric of S_2 , the subset formed by this signifier for which the subject is going to be represented by all the others, namely, precisely the one that subsumes it as subject, it is necessary for X, whatever it may be, to be an element of B here, the first condition is, that X is not an element of X and secondly, we take X as element of O, since the big O collects all of them. So then! What is going to result from this? Is this S_2 an element of itself? If it were an element of itself it would not respond in the way in which we have constructed the subset of elements in so far as they are not elements of themselves. It is therefore not an element of itself. It is therefore not among S alpha, S beta, S gamma. It is

where I placed it in so far as it is not an element of itself. S_2 is not an element of itself. This is what I am writing here: $S_2 \notin S_2$.

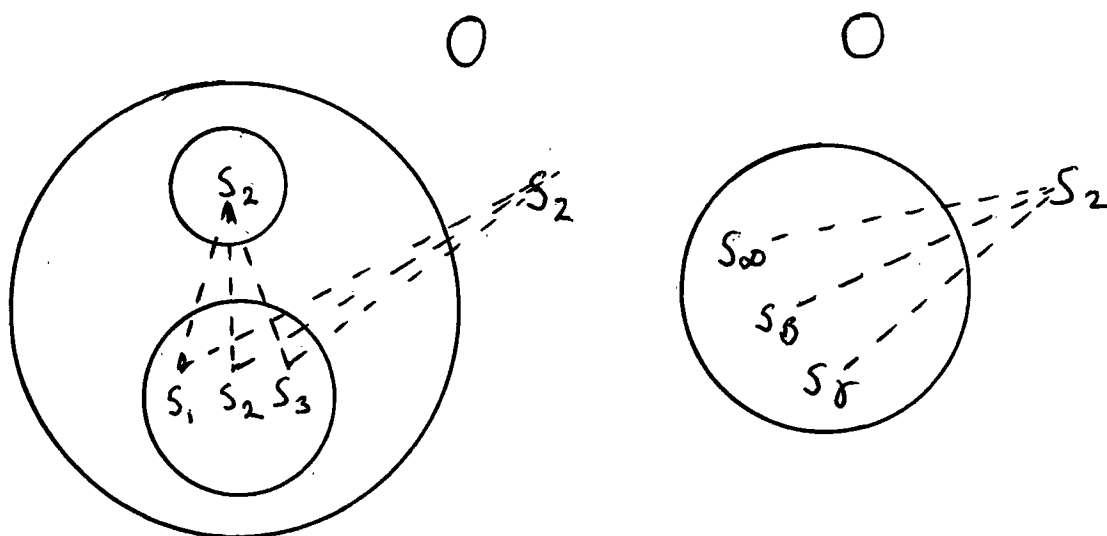

Let us suppose that S_2 is an element of big O, what does that mean? It is that S_2 is an element of S_2 since everything that is not an element of itself while being an element of big O, we have defined as forming a part, as constituting the subset defined by X element of S_2 , S_2 . It must therefore be written that S_2 is an element of S_2 , which we have (59) rejected earlier because the definition of this subset is that it is composed of elements that are not elements of themselves. What results from that?

For those who are not used to these sorts of reasonings which are nevertheless simple, I am picturing it, even though the picturing is here completely puerile. The fact is that S_2 not being an element of big O, can only be pictured here, namely, outside. This demonstrates that the subject in whatever way it intends to be subsumed, either from a first position of the big Other as including itself, or in the big Other by limiting itself to the elements that are not elements of themselves, implies something that, what? How are we going to express this exteriority in which I posited for you the signifier of the subset, namely, S_2 ? This means very precisely that the subject, in the last analysis, cannot be universalised. There is no proposition that says in any way, even in the form of the fact that the signifier is not an element

of itself, that what this defines is an encompassing definition with respect to the subject. And this also demonstrates not that the subject is not included in the field of the Other, but that what can be the point where it is signified as subject, is a point let us say "outside" the Other, outside the universe of discourse. To say, as I also heard being repeated as an echo of my articulation, that there is no universe of discourse, meaning that there is no discourse at all. It seems to me that if I had not sustained here a rather tight discourse, this is precisely what you would have absolutely no idea about. May this serve as an example for you and a support for our method and also a point of expectation for what the next time, 11th December, I hope we will succeed in pushing further in terms of this articulation into what interests us. Not simply in so far as, as psychoanalysts you are the living point of it, but also in so far as psychoanalysands you are looking for it.

Seminar 5: Wednesday 11 December 1968

I sometimes note, privately, little remarks intended for you. So then, in going through these papers I find one that is going to give me my starting point. "*What a pity*", I wrote, I no longer know when, "*that God is used, by what we call the proscription of his name, to conceal*" – this took on the form of a prohibition precisely no doubt where people best knew what is involved in the function of this term, God, namely, among the Jews. You know that among them he has a name that cannot be pronounced – well then! "*this proscription, precisely, helps to conceal*", I had started to say, "*a certain number of references that are absolutely essential for maintaining the "I" in a sufficient light, sufficient for it not to be able to be thrown (jeter) – there is a je in that – to be thrown to the dogs, namely, to professors*".

Which is what I started from the last time in order, in short, as you have heard if not seen, almost despite myself, to push forward at first this "I" reference. Through the intermediary of the God in question I translated what was once put forward in the form: *Eye acher eye, [Hebrew inscription]*, by "I am what I is, *je suis ce que je est*". I told you then that I was myself a little bit overwhelmed by the way this stating that I justified, or believe I justified, came about as a translation. Then I said that, after all, Sinai emerged in spite of me from the ground between my legs. This time I did not receive a little note like the last time. I was expecting nevertheless that someone would point out to me that these words came from the burning bush.

You see what the result would have been if I had told you that the burning bush had come out from between my legs. That is why the sentence orders itself, retroactively. It is indeed because I wanted to define it between my legs that I first of all put Sinai in the place of the burning bush. All the more so because after all, in Sinai, it is the consequences of it that are at stake. Namely, that, as I already remarked in the seminar on *Ethics*, the one who announced himself – in my assertion at least – as “I am what I is”, he, under the form of what ever since has been transmitted in the imperative of the list of the Ten Commandments that are said to be from God, did nothing, I explained it a long time ago, but announce the laws of “I speak”. If it is true, as I stated, that the truth speaks “I”, it appears to be self evident that: “You will adore the one who has said: I am what I is” and you will only adore him alone, by the same consequence: “You will love”, as it is also said, “your neighbour as yourself”. Yourself being nothing (62) other than that to which it is said, in the same commandments, what is addressed as a “thou” and even as a “Thou art” (*tu es*) whose really magical ambiguity in the French tongue I underlined a long time ago. This commandment whose underlying prelude is this “thou art” that establishes you as “I” is also the same slope offered to this “thou-*ing* [*tu-ant*]” that is present in every invocation. And you know that we are not far from the order to respond to it. The whole of Hegel is constructed to show what is built on this.

One could take them one by one, by passing, of course, by way of the one the lie, then subsequently to this prohibition on “coveting the wife, the ox, the ass of your neighbour” who is always the one who kills you (*qui te tue*). It is hard to see what else one could covet! The cause of desire being, indeed, precisely there. It should be pointed out that undoubtedly, through a solidarity that has a certain obviousness, there is no word, properly speaking, except where the closure of one or other commandment preserves it. This clearly explains why, since the world has been the world, no one has exactly observed them. And that is why the word, in the sense that the truth speaks “I” remains profoundly

hidden and only emerges to show a little tip of its nose, from time to time, in the interstices of discourse.

It is necessary then, it is necessary in so far as there exists a technique which trusts this discourse in order to find something there, a path, a way as they say which is presumed not to be unrelated, as it is put – but let us mistrust always the reverse sides of discourse – to truth and life. It would perhaps be well to question more closely what, in this discourse, is grounded as being able to initiate, give us a bridge towards this radical, inaccessible term, that with some boldness the last of the philosophers, Hegel, thought he could reduce to his dialectic.

For us, in an approach that I began to open up, it is before the Other - as allowing a logical failing to be circumscribed, as locus of an original flaw brought to bear on the word in so far as it might respond - that the "I" appears as, firstly subjected (*assujetti*). *a-sujet* I wrote somewhere to designate this subject, in so far as in discourse it is never produced except as divided. The speaking animal can only be embraced by the partner by being first of all subjected. It is because he has always been speaking, that in the very approach to this embrace he can only formulate the "thou art" (*tu es*) by killing himself in it, that he makes the partner other, that he makes of her the locus of the signifier.

Allow me here to come back for a moment to the "I is" (*Je est*) of the last time, since moreover, and from a well informed mind I saw coming back the objection that in expressing it in this way I was opening the door, let us say, to at least a reference to being. That this "is" was, at least by one ear, heard as an appeal to being. To being, (63) since according to the terminology of tradition, it depends on the fact that I state it – by reason of some order of nature, in the most original sense – as subsistent in this nature. Tradition constructs this supreme being in order to answer in it for all 'beings'. Everything changes, everything turns around the one who takes up the place of pivot of the universe, this *x* thanks to whom there is a Universe.

Nothing is further from the intention of this translation than what I formulated, that to make understood, I can take up again as "I am what I is". Let us say that here the "is" is better read and that we come back to state what properly gives the foundation of the truth in the 'I' in so far as it simply speaks. These commandments that sustain it, as I said earlier, are properly anti-physical, and nevertheless there is no way, without referring to them, to tell the truth, as they call it. You should try! In no case! It is an ideal point, make no mistake. No one even knows what that means. Once you hold a discourse, what emerge are the laws of logic, namely, a subtle coherence, linked to the nature of what is called signifying articulation. This is what ensures that a discourse is sustainable or not, through the structure of this thing called the sign, that has to do with what is commonly called the letter as opposed to the spirit. The laws of this articulation are what first of all dominate discourse.

What I began to state in my presentation this year is this field of the Other in order to experience it as conceivable under the heading of the field of inscription of what is thus articulated in the discourse. This is not, at first, to give any incarnation to this field of the Other. It is starting from its structure that there can be defined the possibility of "Thou" that is going to reach us and appeal to something, in a third moment, that will have to say it is "I". It is clear that what is going to show itself is what we are expecting, what we know well. This "I" cannot be pronounced, in all truth is always unpronounceable. This indeed is why everyone knows how cumbersome it is and that, as the laws of the word itself to which I referred earlier recall, it is preferable never to say "I swear".

So then, before prejudging what is involved in the Other, let us leave the question open. If it is simply a blank page, even in this state, it will give us enough difficulties. Because what I showed on the board the last time, is that supposing you have written on this blank page, on condition that it is a page, namely, finite, the totality of signifiers,

which after all is conceivable since you can choose a level where it is reduced to phonemes, it can be proved that on the single condition of believing that you can collect on it anything whatsoever about which you can announce this judgement - it is the subject, the term required (64) by this collecting - this choice will necessarily have to be situated outside this totality. It is outside the blank page that the S_2 , the one that intervenes when I state *that the signifier is what represents the subject for another signifier*. This other signifier, the S_2 will be outside the page.

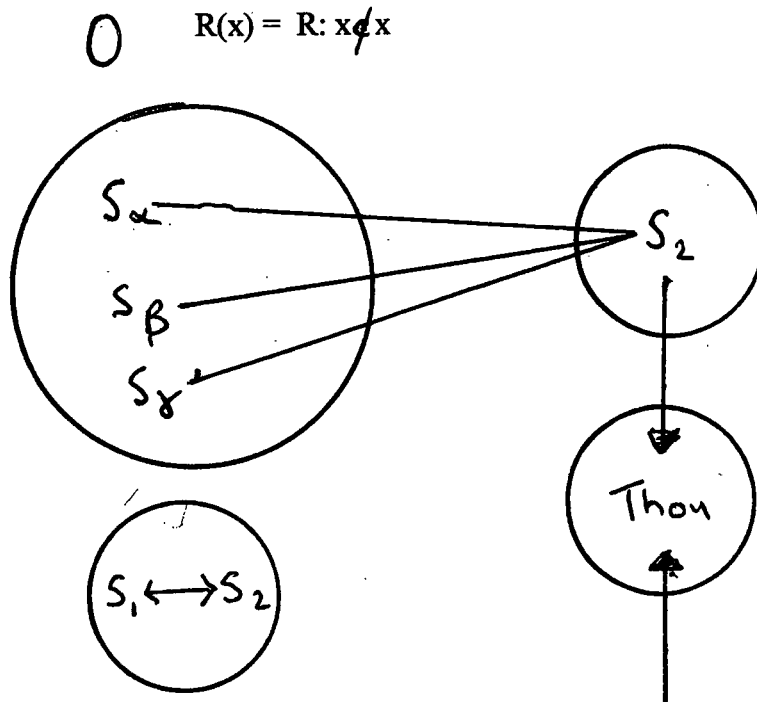

Fig 5

You must start from this phenomenon, that can be proved to be internal to every stating as such, to know everything that we can say subsequently about anything whatsoever that is stated. And that is why it is again worth while delaying on it for an instant.

Let us take the simplest statement. To say that someone announces that it is raining (*il pleut*), can only be judged, can only fully be judged by pausing at the fact that something emerges in that it is said that there is raining (*du "pleut"*). This is the discourse-event through which the very person who says it posits himself as secondary. The event consists in a saying; the one no doubt of which the "he/it" marks the place. But you have to be careful. The grammatical subject that,

moreover, can present, depending on the tongue, distinct morphologies, that are not necessarily isolated. The grammatical subject here has a relationship with what I earlier called 'outside the field', more or less individualised as I have just recalled it. Namely, moreover, for example, reduced to an ending, "*pleu*". The *t*, this little *t* moreover that you will find wandering in all sorts of corners of French itself, why does it lodge itself here where it has nothing to do? In an *orne-t-il* [does he embellish], for example. Namely, where it was not in the conjugation. This grammatical subject then, so difficult to properly circumscribe, is only the place where something comes to be represented.

Let us come back to this S_1 in so far as it is what represents this something, and let us recall that when the last time we wanted to extract this S_2 from the field of the Other, as appeared necessary, because it could not maintain itself in it, in order to collect together the S alpha, S beta, S gamma in which we claim to grasp the subject. It is in so far precisely as in the field of the Other we have defined these three S 's by a certain function, let us call it R defined elsewhere, namely, that x was not an element of x and that this $R(x)$ (Fig 5) is what transformed all the signifying elements on this occasion into something which remained undetermined because open, which took on, in a word, the function of a variable. It is in so far as we have specified what this variable must correspond to, namely, a proposition that is not an indifferent one, not, for example, that the variable must be good, or anything else whatsoever, or red or blue but that it ought to be subject, that there arises the necessity for this signifier as Other, that it cannot in any way be inscribed in the field of the Other. This signifier is properly, in the most original form, what defines the function described as knowledge. I will of course have to come back to this, because this place, even as compared to what was stated up to now as regards logical functions, is perhaps not yet sufficiently emphasised. To try to qualify the subject as such puts us outside the

Other. This “puts us” (*nous met*) is perhaps a form of *noumen* that will take us further than we think.

Let it be enough for me here to question whether it is not true that the difficulties that come to us, in a logical reduction, from the classical statements, I mean the Aristotelian ones of the universal and particular propositions, come from the fact that people do not perceive that it is there, outside the field, the field of the Other, that there ought to be placed the “all” and the “some”. And we would be less embarrassed in perceiving that the difficulties generated by the reduction of these classical propositions to the field of quantifiers results from this. Rather than saying that all men are good, or bad, or whatever, the correct formula would be to state men, or anything else, anything that you can provide with a letter in logic, are all good, or are some good. In short, that by putting the syntactical function of the universal and the particular outside the field, you will find fewer difficulties in reducing them subsequently to the mathematical field. Because the mathematical field consists precisely in working desperately to ensure that the field of the Other as such holds up. It is the best way of testing that it does not hold up. But to test it by articulating all the stages, because it is at many different levels that it does not hold up. The important thing is to see that it is in so far as this Other is as they say technically, “consistent”, that stating turns into demand, this before anything whatsoever, that carnally may correspond to it, has even come to lodge itself in it.

The interest of going as far as possible in the questioning of this field of the Other as such, is to note in it that it is at a series of different levels that its failing is perceived. It is not the same thing, and in order to put it to the test mathematics brings us an exemplary field of experience, because it can allow itself to limit this field to well defined functions, arithmetic, for example. It matters little yet, for the moment, what in fact this arithmetical research reveals. You have heard enough (66) about it to know that these fields, even if you choose the most

simple, there is great surprise when we discover, for example, that completeness is lacking. Namely, that one cannot say that anything whatsoever that is stated there can either be proved or can be proved not to be. But, more again, that in such a field, and among the most simple, it can be put in question whether something, some statement can be proved in it, that another level is outlined of a possible proof, that a statement cannot be proved in it. But it becomes very curious and very strange that in certain cases this step that can be proved itself escapes for something that is stated in the same field. Namely, that since it cannot even be affirmed that it is not provable, a distinct dimension is opened up, called the *undecidable*.

These echelons, not of uncertainty but of defect in the logical texture, are the very ones that may allow us to grasp that the subject as such might, in a way, find there his support, his status. In a word the reference that, at the level of stating, is satisfied by adhering to this fault itself. Does it not seem to you that just as, perhaps, - on condition that such a numerous audience would be so obliging - as perhaps we can make it felt in some construction, even if it entails, as already I did in connection with the field of the Other, abbreviating it, it may be, in a way, rendered necessary in a statement of discourse, that there could not even be a signifier there, as, it appears, one can do. Because in tackling this field from the outside, from logic, nothing prevents us, it appears, from forging the signifier by which there is connoted what is wanting in the signifying articulation itself. If this something could, and I am still leaving this in the margin, be articulated, and this has been done, that proves that this signifier with which a subject, in the final analysis, can be satisfied by identifying himself to it as identical to the very lack of discourse, cannot be situated, if you will allow me here this abbreviated formula, are not all of those here who are analysts not aware that it is for want of any exploration of this order that the notion of castration, which is indeed what I hope you have sensed in passing to be analogous to what I am stating, that the notion of castration remains so vague, so uncertain and is handled with the

thickness and the brutality that we know? In truth, in practice, it is not handled at all. People substitute for it quite simply what the other cannot give. People speak about frustration when it is something quite different that is at stake. On occasion, it is along the path of privation that people approach it, but as you see, this privation is precisely what participates in this defect inherent to the subject that it is a matter of approaching.

In short, I will only - to leave what today I am only tracing the outline of without being able even to foresee what between now and the end of the year I will manage to get you to tolerate - indicate simply, in (67) passing, that if something was able to be stated in the field of logic, you can, all those, at least, who here have some notion of the last theorems advanced in the development of logic, all of those know that it is very precisely in so far as this S_2 , in connection with a particular system, the arithmetical system for example, properly plays its function in so far as it is from outside that it counts everything that can be made into a theory within a well defined O . That it is in so far, in other terms, that a man of genius called Gödel had the idea of perceiving that it was by taking literally "it counts", that on condition of giving to each of the statements of the theorems as situatable in a certain field, their number called the *Gödel number* that something surer could be approached than had ever been formulated about these functions that I could only make an allusion to in what I have previously stated, when they are called *completeness* or *decidability*.

It is clear that everything is different from a time in the past when it could be stated that after all mathematics was only tautology, that human discourse can remain, because it is a field that, according to this assertion, is supposed to have come from tautology, that there is somewhere an O that remains a big O identical to itself. Everything is different from the time that this is refuted, refuted in the surest fashion. That it is a step forward, that it is something that has been learned and that for anyone who finds himself confronted in experience, in an

experience which appears to us like a transcendental aporia with regard to natural history as analytic experience does, we do not see the interest in going to find support in the field of these structures. Of these structures, as I said in so far as they are logical structures to situate, to put in their place this x that we are dealing with in the field of a quite different stating, the one that the Freudian experience allows and that moreover it directs.

It is therefore first of all in so far as the Other is not consistent that stating turns into demand and this is what gives its bearing to what in the big completed graph, the one that I drew here (Fig 6), is inscribed in the form of $\$ \diamond D$. All that is at stake is what is stated in a way that is not stated in what distinguishes any statement. The fact is that there is subtracted here this "I say that" which is the form where the "I" is limited. The "I" of grammar can be isolated outside any essential risk, can be subtracted from stating, and by this fact reduces it to the statement since this "I say that", by not being subtracted, leaves it whole and entire that, from the very fact of the structure of the Other, all stating, whatever it may be, becomes demand. Demand of what this Other is lacking. At the level of this $\$ \diamond D$ the double question is: *I ask myself (je me demande) what you desire*, and its double which is precisely the question we are highlighting today, namely: *I ask you, not who I am, but further again what I is (ce qu'est Je)*.

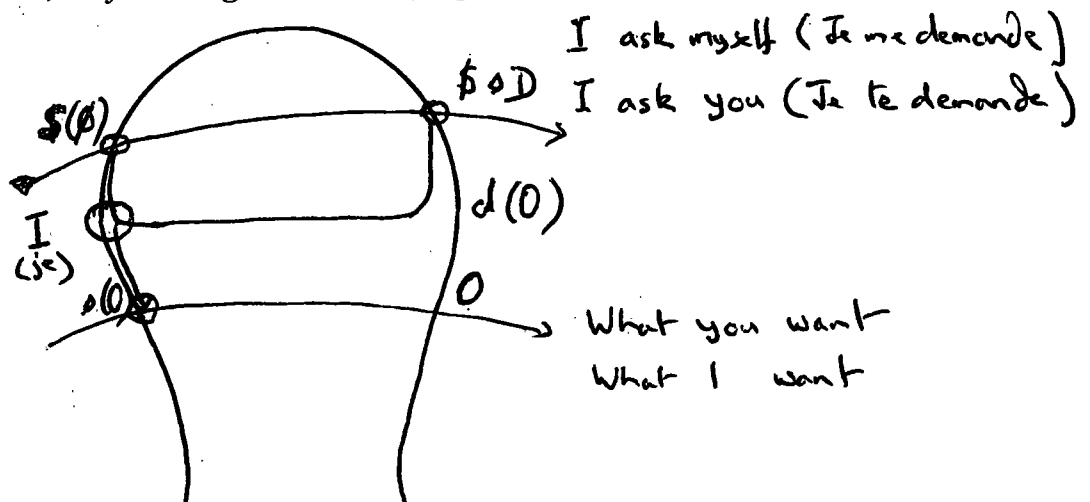

Fig 6

(68) Here there is installed the very knot, the one I formulated in putting forward that the desire of man is the desire of the Other.

Namely, that, as I might say, if you take the vectors as they are defined on this graph, namely, coming here from the start of the pure signifying chain, in order here, from the cross roads designated by $\$ \diamond D$, with this return that completes the retroaction marked out here, it is well and truly at this point described as *d of O*, desire of the Other, that there converge these two elements that I articulated in the form of *I ask myself what you desire*. It is the question plugged into the very level of the setting up of O. "What you desire", namely, what you are lacking linked to the fact that I am subjected to you.

And on the other hand, I ask you what "I" is, the status of the "I" as such, in so far as it is here that it is established. I am marking in red this status of the "Thou", constituted by a convergence, a convergence that does occur. If all stating as such, the indifferent stating of analysis, because this is how the rule posits it in principle, turns into demand, it is because it is radically, from its very function as stating to be demand, concerning the "Thou" and the "I". As regards the "Thou", it is a convergent demand, a questioning stimulated by lack itself in so far as it is at the heart of the field of the Other, structured from pure logic. This is precisely what is going to give its value and its bearing to what is outlined, just as vectorised on the other side of the graph. Namely, that the division of the subject is made tangible there as essential to what posits itself as "I". To the demand of "What is I?", the structure itself replies by this signifying refusal of O, as I inscribed it in the functioning of this graph. In the same way the "Thou" here, establishes it from a convergence between the most radical demand, the one addressed to us analysts, the only one that sustains in the final term the discourse of the subject. "I come here to ask you". In the first phase, it is indeed "who I am" that is at stake even though it is at the level of "who is I" that the response is given. It is of course because logical necessity is what gives this step back (*recul*).

A convergence, then, of this demand and here, something of a promise, of something that, in S_2 is the hope of gathering together this "T". It is (69) indeed what in transference I called the *subject supposed to know*. Namely, this prime conjunction, S_1 linked to S_2 , in so far, as I recalled the last time, in the ordered pair, it is it, it is this conjunction, this knot that grounds what knowledge is.

What does that mean? If this "T" is only tangible in these two divergent poles, one called what I here am articulating as the "no", the refusal that gives form to the lack of the reply, and this something different articulated there as $s(O)$, this meaning, what is it? Because is it not tangible that the whole discourse that I am spinning out to give the framework of the "T" of the questioning from which this experience is established, is it not tangible that I am pursuing it while leaving outside, at least up to this point that we have come to here, any meaning?

What does that mean? That after having formed you for long years to ground, on the differentiation of a linguistic origin, the signifier as material, from the signified as its effect, I am allowing it to be suspected, to appear here that some mirage lies at the source of this field defined as linguistic, the sort of astonishing passion with which the linguist articulates that what he tends to grasp in the tongue is pure form, not content?

Here I am going to bring you back to this point, that in my first lecture, I first brought forward before you, and not unintentionally, in the form of the pot. Nothing, those who are taking notes should know, is unpremeditated in what one could call, at first sight, my digressions. If I came back in an apparently digressive way to the mustard pot, it is certainly not without reason. And you may remember that I gave a place to the fact that, in the first forms of its apparition, it is to be strongly signalled, that there are never lacking, on the surface of this pot the marks of the signifier itself. Is there not introduced here

something in which the "I" is formulated? The fact is that what sustains the whole of human creation, of which no image has ever appeared better than the work of the potter, is very precisely to make this something, the utensil, that pictures for us by its properties, that pictures for us this image that the language of which it is made – for where there is no language there is no worker either – that this language is a content. It is enough to think for a moment that this very fabrication is there to introduce the reference to this philosophically traditional opposition of form and content. It is not for nothing that in my first introduction of this pot I signalled that where it plays the part of an accompaniment to death in burial there is put this addition that properly speaking holes it. It is indeed in effect because its spiritual principle, its origin in language, the fact is that there is that there is somewhere a hole through which everything escapes. When it rejoins at their place those who have gone beyond, the pot for its part also, finds its true origin, namely, the hole that it was designed to mask in language. There is no meaning that does not leak away as regards (70) what a cup contains, and it is quite curious that I made this discovery that was certainly not made at the moment that I stated this function of the pot for you. Searching, my God, in what I usually refer myself to, namely, in the *Bloch et von Wartburg*, what is involved in a pot, I had, as I might say the happy surprise of seeing that this term - as is testified, it appears, by lower German and Dutch with whom we share it - is a pre-Celtic term. Therefore it comes to us from afar, from the Neolithic no less. But there is better. It is that because of having this idea, at least to give it a little base, we ground ourselves on these pots that are found before the Roman invasion, or more exactly as representing what was established before it, namely, the pots that are dug up, it appears, in the region of Trier. *Bloch et von Wartburg* express themselves as follows: "We see inscribed there the word Potus". This is enough, for them, to designate the very ancient, because it is a usage that is at stake, that they indicate that Potus, hypochoristically, as they put it, can designate the makers. What matter! The only thing that is important for me is that when the pot

appears it is always marked on its surface by a signifier that it supports. The pot here gives us this function distinct from that of the subject, in so far as in the relation to the signifier the subject is not a preliminary but an anticipation. It is supposed, *upokeimenon*. It is its essence, it is its logical definition, supposed, almost induced, certainly, it is not the support. On the contrary, we can legitimately give to the signifier a fabricated support and even, I would say, a utensil. The origin of the utensil in so far as it distinguishes the field of human fabrication is even properly speaking there.

The meaning as product, this is what serves, and as a lure, to veil from us what is involved in the essence of language, in so far as, by its essence, it properly does not mean anything. What proves it is that the assertion in its essential function is not an operation of meaning and this indeed is how we analysts understand it. What we are seeking is what, not from the Other, but outside the Other as such, suspends what is articulated from the Other, the S_2 , as outside the field. Here is the question of knowing what is involved in the subject, and whether this subject cannot in any way be grasped by discourse; here also is the justification for what can be substituted for it.

The sense of what is involved in castration is balanced with that of enjoyment. But it is not enough to grasp this relation as assuredly in what was manifested in a time that is close to us, of something in which at the same time this scream, need for truth, is an appeal to enjoyment. It is assuredly not enough to aspire to enjoyment without hindrances, if it obvious that enjoyment can only be articulated for every individual – himself included in language and the utensils – can only be articulated in this register of remainder inherent to one and the other that I defined as the *surplus enjoying*. It is here that on 8th of January we will take up our discourse again.

Seminar 6: Wednesday 8 January 1969

(71) So then I wish you a Happy New Year, the New Year of '69. It is a good number! To open it, I am pointing out to you that on one or other occasion I always receive from some horizon a little gift. The last one, the one on this occasion, is a little article that appeared in the January 1st number of the *Nouvelle Revue Française* in which there is an article entitled "Some extracts from the style of Jacques Lacan". In effect, huh, my style is a problem! This is what I could have begun my *Ecrits* with. It is an old article that I never re-read, which was precisely on the problem of style. Perhaps if I re-read it, it will enlighten me! Meanwhile, of course, I am the last one to be able to account for it, and my God, I cannot see why somebody else should not try. This has happened. It comes from the pen of a professor of linguistics and I do not have to judge personally the result of his efforts. I will make you the judge of them. In general, I rather had an echo that in the present context, where suspicion is thrown, in any case, in some out of the way places, about the general quality of what is dispensed in terms of teaching from the mouths of professors, one might think that it was perhaps not the time to publish this. It is not the most opportune moment. In any case, I have heard that some people did not find it very good.

Anyway, as I said to you, you can be the judge. For my part I am not complaining about it! I find it difficult to see how anyone could get the slightest idea in it of what I have spread as a teaching.

Nevertheless, there is a point; I am supposed to have dared, it appears, to write somewhere: "Freud and me". You see that, huh, he doesn't think that he's a nobody! This has perhaps not quite the sense that the indignation of the author thinks he should give it, but it shows clearly the field of reverence, at least in certain domains, in which we live. Why, for this author who admits to not having the slightest idea of what Freud contributed, should there be something scandalous that someone who spent his life at it should say "Freud and me"? I would say more, reverberating myself from this outrage to the degree of respect that I am reproached with here, I could not do otherwise than remember the anecdote that I quoted here, about the time when in the company of P'tit Louis, as I recalled, I spent some time in the most difficult way at the tiny industries that people on the coast live on. With these three excellent people whose names are still dear to me, I (72) did many things that I am going to pass over. But I also happened to have with P'tit Louis the following dialogue. It was, as I told you, about a sardine tin that we had just eaten and that was floating next to the boat, and P'tit Louis said these very simple words to me: "Hah, this tin, you see it because you are looking at it. Well then it, for its part does not need to see you to look at you".

The relation between this anecdote and "Freud and me" leaves the question open of where I place myself in this couple. Well then reassure yourselves, I place myself always as the same place, at the place where I was, and where I still remain, alive. Freud does not need to see me in order to look at me. In other words, as a text I already quoted here states, "a living dog is worth more than the discourse of a dead person", especially when this has come to the degree that it has reached of international rottenness.

What I am trying to do, is to give to Freudian terms their function in so far as what is at stake in these terms, is an overturning of the very principles of questioning. In other words – which does not mean, says the same thing – in other words what is involved here is the minimal

requirement of the passage to this renewed questioning. The minimal requirement is the following, it is a matter of making psychoanalysts. Because this questioning, in order to be posed, requires the subject to be replaced in his authentic position, and that is why I recalled at the beginning of this year what position was at stake. It is the one that puts it from the beginning into one of dependency on the signifier. So then around this requirement, this fundamental condition, there is organised everything acceptable that is affirmed up to now whose elements existed in the first practice of analysis where people undoubtedly took into account word play and language play. And with good reason! This level, I simply took up again, legalised I might say, by laying hold of what linguistics provided in this foundation that it brought forward called phonology, the operation of the phoneme as such. Because it was really necessary to see that what Freud had opened out quite simply found its status there, with some delay certainly, but obviously with less delay than that of the public in general, and at the same time psychoanalysts.

This is not a reason to remain there. This is why you see me, whatever might otherwise have been the degree of competence I previously showed in this use of what is, after all, only a part of linguistics, pursuing this work that consists in grasping everywhere already established disciplines offer the opportunity, pursuing this research that, from the level where it was really a matter of a coincidence, because it is really phonematic material itself that is at stake in the operations of the unconscious, pursuing it at the level where another discipline allows us to map out an isomorphism of approach between this status of the subject and what it develops, but that may just as well (73) reveal itself as covering an identity of material, as I already affirmed.

And what is this discipline? I would call it logical practice (*la pratique logicienne*) a term which does not seem to me a bad one to designate what exactly is involved, because it is from a place where this practice

is exercised that it now finds what makes it necessary. But it is not inconceivable that it should find itself being brought to bear elsewhere. The place where effectively it is exercised, where something has happened that detached logic from the tradition in which, throughout the centuries, it remained enclosed, is the domain of mathematics. It is certainly not by chance, it was altogether foreseeable, unfortunately, subsequently, that it would be at the level of mathematical discourse that logical practice would find itself being exercised. What could be more tempting, in effect, than this place where discourse, I mean the demonstrative discourse, seemed to be based on a complete autonomy, an autonomy with respect to what is called experience. It seemed, it could not [?] have seemed that this discourse only took its certainties from itself, namely, from the requirements of consistency that it imposed.

What are we going to say about this reference? Are we going, in order to give a sort of image of this logic that has attached itself to the mathematical domain, to designate it as a recess of what would only be itself, in a certain style of thinking for mathematics, also something separated off, even though sustaining the scientific current. Something that, with regard to a certain progress, would be that and then that again: *recessus*. It is an image, but an image that it is worthwhile exercising because we are going to see that nothing of the kind is at stake.

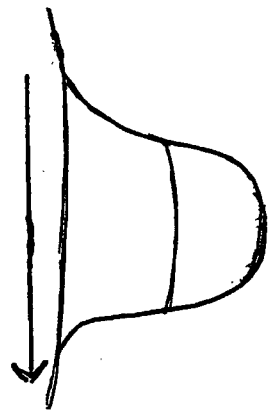

It is an opportunity to recall that the recourse to the image to explain metaphor is always false. Any domination of metaphor by the image ought to be suspect, its support being always the specular, anthropomorphic body image, which is faulty. Because it is very simple to illustrate again that it is only an illustration, this image simply masks the function of orifices. Hence the value as an apologue of my holed pot on which I left you last year. It is quite clear that one does not see the hole in this pot in the mirror if one looks through the aforesaid hole. Hence the inverted value of this utensil that I only put

forward, I recalled it also in leaving you, to indicate the fact that under these simplest, most primary shapes what human industry fabricates is constructed properly speaking to mask what is involved in the true effects of structure. It is with this name that I return - and my digression was constructed to introduce it - to this explicit distinction by recalling that form is not formalism. It happens in certain cases that (74) even the linguists - I am not speaking of course about those who do not know what they are saying - make little errors on this point. The author of whom I spoke earlier, who gives me no proof of his explicit competence, charges me with having spoken about Hjelmslev, which is precisely what I never did. On the contrary, the name of Jakobson, as far as I could see - because I read his article, as he puts it himself, diagonally - is remarkably absent, which no doubt avoids him having to judge whether yes or no the use that I made of the functions of metaphor and of metonymy is relevant.

To return to this crucial point about the distinction between form and formalism, I will try, because this is what is first necessary to illustrate it from some forms. It is very necessary for whoever is engaged as is the case for the psychoanalyst in the cuts that, by affecting a field to which the body is exposed, culminate indeed at the fall of something that has some form. Nevertheless, I would recall - to touch on one of these images that psychoanalytic experience isolates and one does not know how - the cup/cut (*coupe*) that contains the milk, the one that evokes its being taken inside out under the name of breast, the first of the o- objects, this cut is not the structure through which the breast is affirmed as homologous to the sticking on of the placenta, because it is the same physiologically, and, unless the word comes into play, its reality. Only even to know what I have just said, namely, before this breast is implicated in the dialectic of the o-object, even to know what it is there, I mean physiologically, a rather advanced zoology is necessary. And this by the explicit use, otherwise it is not visible, of a classification whose relations to logic one would be wrong to minimise. Aristotelian logic has been reproached for having, with its

use of the terms of genus, species, simply stuck onto a zoological practice the existence of individuals zoologically defined. One must be consistent and, if one states this more or less reprehensible remark, note that inversely this zoology itself implies a logic, made up of a structure, and of a logical structure, of course. As you see, it is the frontier between what every explorative experience already implies and what is going to be put in question about the emergence of the subject.

In mathematics, formalism will be brought out better in its function as cut. And in effect, what do we see as regards what is involved in the way it is used? Formalism in mathematics is characterised as follows. It is grounded on the attempt to reduce this discourse that I announced earlier, mathematical discourse, a discourse of which people have been able to say – and certainly not from the outside, it has also been said from the outside, it was what Kojève said but he was only taking it up from the mouth of Bertrand Russell – that this discourse has no sense and that one never knows whether what is said in it is true. An extreme, paradoxical formula regarding which it is worth recalling that it comes from Bertrand Russell one of the initiators of the logical (75) formalisation of this discourse itself. This attempt to take this discourse and to submit it to this test that we could define in short in these terms, to take one's assurance from what indeed it appears to be, namely, functioning without the subject. Because indeed to make even those who are not immediately with it sense what I am designating here, who then will ever speak, as regards what guarantees mathematical construction, of any incidence whatsoever of what can be detached from it as observer? There is no conceivable trace there of what is called "subjective error", even if it is here one can give the systems that allow it to be given a measurable sense elsewhere. This has nothing to do with mathematical discourse itself; even when it discourses about subjective error, it is in terms – I mean the terms of the discourse – for which there is no middle. They are exact,

irrefutable, or they are not so. Such is at least its requirement; nothing will be accepted that is not indispensable as such.

It nevertheless remains that there is the mathematician. The use, the search for the formalisation of this discourse consists, as I said just now, in assuring oneself that even if the mathematician completely evaporates, the discourse holds up of itself. This implies the construction of a language that is very precisely the one called rather appropriately then, as you see, mathematical logic. It would be better to say practice of logic, logical practice in the mathematical domain, and the condition for realising this test is presented in a double form that may appear an antinomy. On one point this language seems to have no other concern than to reinforce what is involved in mathematical discourse whose character I have just reminded you of, namely, to refine its unequivocal character. The second condition, and this is why it appears antinomical, is that this unequivocal concerns what? Always something that one can call object, naturally not an indifferent one. And that is why, in the whole attempt to extend this new logical practice beyond the field of mathematics – to illustrate what that means, I am speaking about Quine's book *Word and object*, for example – when it is a matter of extending this practice to common discourse, people feel themselves required to start from what is called object-language, which is nothing other than to satisfy this condition of a language without equivocation. An excellent opportunity moreover to highlight what I always put the emphasis on from the start of my reference to language. It is of the nature of discourse, of fundamental discourse, not simply to be equivocal, but to be essentially made up of the radical slippage of meaning, essential for any discourse.

A first condition then, I said, to be unequivocal. This can only be referred to a certain object aimed at, of course, in mathematics, not an object like others. And that is why, once Quine transfers the handling of this logic to the study of common discourse, he speaks about “ob” (76) language, stopping prudently at the first syllable! But on the other

hand, the second condition is that this language must be pure writing. That nothing of what concerns it ought to be constituted only by interpretations. The whole structure – I mean that one can attribute to the object – is what constructs this writing. Hence there is nothing in this formalisation that is not posited as interpretation. To the nevertheless fundamental equivocation of common discourse there is opposed here the function of isomorphism, namely, what constitutes a certain number of domains as falling under the capture of one and same written formula.

When one enters into the experience of what is thus constructed, if one takes a little trouble that I did not believe was unworthy of me to take, as the article evoked above seems to suppose, and if one approaches Gödel's theorem, for example – and after all it is within the reach of each of you, it is enough to buy a good book or go to some good places. We have gone multi-disciplinary, after all it is perhaps a requirement that did not emerge from nothing. It is perhaps from seeing the trouble one has from what is improperly called mental limitation – a theorem like this, moreover there are two of them, will tell you that as regards the domain of discourse that seems to be most assured, namely, arithmetical discourse, two and two are four all the same, there is nothing on which one is more securely based. Naturally people did not remain at that! Since that time, many things have been glimpsed, but which in appearance are only in the strict development of this two and two are four, in other words, that starting from there, there is a discourse that, to all appearances, can be called consistent. This means that when you state a proposition in it, you can say yes or no, this is acceptable, is a theorem, as they say, of the system. This one is not and is its negation which is, on this occasion, if one thinks one should take the trouble of making a theorem of everything that can be posited there as negative. Well then, this implies that this result is obtained by way of a series of procedures on which no doubt is brought to bear and that are called proofs.

The progress of this logical practice has allowed to be assured, but only thanks to the use of formalisation processes, namely, by putting into two columns, as I might say, what is stated from the first discourse of mathematics, and this other discourse subjected to this double condition of getting rid of equivocation and of being reduced to a pure writing. It is starting from there and only starting from there, namely, from something that distinguishes the first discourse, the one in which mathematics has boldly made all this progress and without having, a curious thing, to correct it epoch by epoch, in a way that ruins the acquisitions generally accepted in preceding epochs, in opposition to this discourse pinpointed on this occasion, and very wrongly in my view, by the term of meta-language – the use of this formal language (77) called, for its part, no less wrongly, language – because it is from something that a practice isolates as a closed field in what is quite simply language, the language in which mathematical discourse could not properly speaking be stated. It is starting from there, I am saying, that Gödel shows that in this apparently most certain system of the mathematical domain, that of arithmetical discourse, the very supposed consistency of discourse implies what limits it, namely, incompleteness. Namely, that by starting even from the hypothesis of consistency, there will appear somewhere a formula, and it is enough for there to be one for there to be many others, to which it cannot, by the very paths of the accepted proof *qua* law of the system, be answered yes or no. The first phase, the first theorem.

The second phase, the second theorem. Here I must abbreviate. Not simply can the system, I mean the arithmetical system, not therefore assure its consistency except by making of it its very incompleteness, but it cannot, I am saying in the very hypothesis grounded on its consistency, demonstrate this consistency within itself.

I took a little trouble to get across here something that is not assuredly properly speaking our field, I mean the psychoanalytic field, if it is defined by some olfactory apprehension or other. But let us not forget

that at the moment of telling you that it is not properly speaking about what the sentence implied that I am finishing with another subject, you see clearly where I land, on this vital point. Namely, that it is unthinkable to operate in the psychoanalytic field, without giving its correct status to what is involved in the subject.

What do we find in the experience of this mathematical logic? What, if not precisely this residue where the presence of the subject is designated? At least is this not what a mathematician himself, certainly one of the greatest, Von Neuman, seems to imply in making this rather imprudent reflection that the limitations, I mean the logically tenable ones, it is not a matter of any antinomy, of any of these classical mind games that allow it to be grasped that the term obsolete, for example, is an obsolete term. And that starting from there we are going to be able to speculate on the predicates that are applied to themselves and those that are not so applied, with all that this involves as a paradox. That is not what is at stake. What is at stake is something that constructs a limit that uncovers nothing, no doubt, that mathematical discourse has itself not discovered since it is on this field of discovery that it tests out a method that allows it to question it about something that is all the same essential. Namely, up to what point can it account for itself, up to what point can its coincidence with its own domain be affected if these terms had a sense, while it is the very domain in which the notion of content had properly speaking been (78) emptied. To say with Von Neuman that after all this is all very fine because it bears witness to the fact that mathematicians have still a reason to be there, since it is with what presents itself there in its necessity, its proper *ananke*, its necessities of detour, that they will indeed have their role. It is because something is missing that the desire of the mathematician is going to come into play.

Well then, I think that here indeed Von Neuman is going a little too far. Namely, I believe that the term residue is wrong, and that what is revealed here about this function that already I have evoked from

several angles under the title of the impossible has a different structure than the one that we have to deal with in the fall of what I call the o-object. Much more, I believe that what is revealed here in terms of lack, even though no less structural, reveals no doubt the presence of the subject, but no other subject than the one that brought about the cut, the one that separated out the so-called meta-language from a certain mathematical field, namely, quite simply its discourse, the cut that separates this language from another isolated language, from an artificial language, from formal language. That is why this operation, the cut, is no less fruitful in so far as it reveals properties that are indeed the very stuff of the mathematical discourse, in that whether it is a question of whole numbers on the status of which you know people have not finished and that people will scarcely finish cavilling about for some time as to whether these numbers have such a place ontologically or not is a question that is totally foreign to the experience of discourse in so far as it operates with them and that can perform this double operation, 1) construct itself and 2) formalise itself.

We are far, no doubt, at first sight, from what interests us at the centre, and I do not know, given the little time that remains to me, how I can bring you back to it today. Nevertheless, allow me to recall rapidly, to sketch out here that the point that we had got to at the end of our last session was the following: the truth speaks "T". What about this "T"? If the "T" is here to be strictly distinguished from the subject that as you see one can somewhere can be reduced to the function of the cut, impossible to distinguish from the one called unary trait in so far as it isolates a function of the One as simply unique, and simply a cut in numeration. The "T" is not for all that in any way assured, because we can say the following about it. That it is and that it is not according to whether, as subject, it operates, and that operating as subject, it is exiled from the enjoyment which for all that is no less "T".

And it is here that I must remind you that in this graph (fig 6), constructed to respond very precisely to the constitutive questioning of analysis, what lies between the two lines called stating and stated, namely that, cut again by that of signifying material, by the elementary differential chain of phonemes, it allowed us to guarantee these four (79) crossing points whose status is given precisely in terms of writing. Here the \$◇D, here the O, the field of the Other, here the small s of O, namely meaning, and here finally the big S of Ø, the signifier of something approached several times, but never completely elucidated called the O barred. You know that here, homologous to the imaginary return line that integrates the narcissistic relation into the field of the statement, homologous, I am saying, you have here, halfway incarnated in this written form what is necessary at the pure enunciating level which is the following, namely, what is articulated as \$◇D, which means here as elsewhere, everywhere I write it, *demand*. Demand, not an indifferent one, "I ask myself". And let us write here in this form, "what you want", the desire of the Other, in this complete ambiguity that still allows there to be written "I ask you...what I want", since my desire is the desire of the Other. There is no distinction here, except one induced by the very function of stating in so far as it bears in itself its sense as first of all obscure, as if all stating, as I already said, the most simple, only evokes its sense as a consequence of its own emergence. "It is raining" is a discourse-event and it is only secondary to know what it means about rain. Anyone at all is capable of evoking "It is raining" in a particular context. It can have very different senses. Do I need in this connection to recall that "Get out" does not sound the same everywhere as it does in *Bajazet*.

If there is something that is more important to map out from this graph than this discourse that accompanies it, it is the structural vectors as they are presented here at the level where the You, as dominating the I, as the you-ing (*tu-ant*) as I said at the level of the desire of the Other, the vectors that converge. It is around the desire of the Other that the demand of the discourse, of the discourse as we organise it in analytic

experience, of the discourse precisely that, under its aspect that fallaciously pretends to be neutral, leaves open the sharpest accent of the demand at its point. It is in a converging fashion around the desire of the Other that everything that is at the source, as the retroactive arrow indicated, everything that is at the source converges towards the desire of the Other.

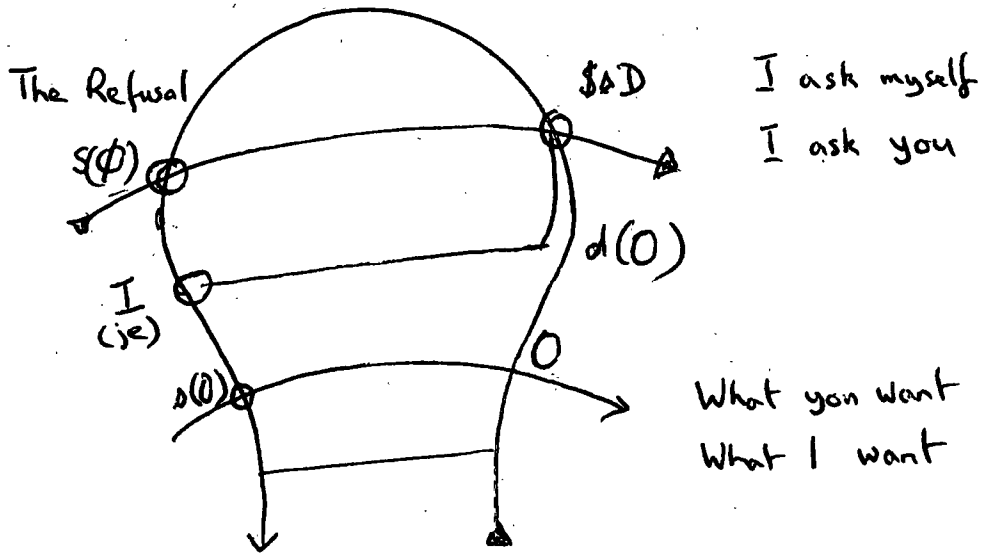

(80) It is at the point that, as imaginary support, corresponds to this desire of the Other, what I have always written under the form of $\$ \Delta o$, namely, the phantasy, that there lies hidden this function of the "I". The "I" in so far as, contrary to the point of convergence called desire of the Other, it is in a diverging fashion that this "I" hidden under the $\$ \Delta o$, is directed under the form that precisely I called at the beginning that of a true questioning, of a radical questioning, towards the two points where there lie the elements of the answer. Namely, in the line on top, big S, which means a signifier, a signifier of the fact that O is barred, and which is precisely what I took, what I also gave you the trouble to have a support to conceive of what I am here stating. Namely, that the field of the Other does not secure, does not assure at any place, to any degree, the consistency of the discourse that is articulated here, in any case, even the most apparently certain.

And on the other hand, the lower line, a meaning in so far as it is fundamentally alienated. And it is here that you must grasp the sense of my starting this year with the definition of the *surplus enjoying* and

its relationship with everything that one can call, in the most radical sense, the means of production, at the level of meaning, if already the pot, as I have pointed out to you, is only an apparatus to mask the consequences of discourse, I mean the major consequences, namely, the exclusion of enjoyment.

You see that in this way there is put into this *Entzweiung*, the term is Hegelian, into this radical division which is the very one at which Freud's discourse culminates at the end of his life, the division of the "I" articulated as such. It is nothing less than that between these two terms, namely, the field where the Other in a way, in some imagining, for a long time that of the philosophers, could correspond to any truth and where precisely this is cancelled out by the simple examination of the functions of language. I mean that we know how to make intervene in it the function of the cut that answers "no!", no to the God of the philosophers. And that, on the other hand, on a different register, the one in appearance where enjoyment is waiting. It is there precisely that it is a slave, and in the same way people said that up to now that one could reproach psychoanalysis for overlooking the conditions in which man is subjected to the social, as it is put, without seeing that one is contradicting oneself. The materialism described as historical only has a sense precisely by grasping that it does not depend on the social structure since it affirms itself that it is on the means of production. Namely, only from that with which one makes things that deceive *surplus enjoying*. Namely, that, far from being able to hope to fill the field of enjoyment, are not even sufficient for what is lost in it, because of the Other.

I was not able, my God, as usual, to go any quicker than my own violins. Nevertheless, I can announce here where I intend to take things up the next time. I will tell you that it is not in vain that from (81) the mouth of the God of the Jews, what I held onto is "I am what I is". It is indeed here that it is time for something to be finally dissipated, something already clearly said by someone called Pascal. If

you wish, perhaps this will help you to understand what I am going to tell you the next time, to read a little book that has appeared in Desclée de Brouwer under the title of *Pascal's wager* by a M Georges Brunet, who knows admirably well what he is saying. As you have seen earlier this is not true for every professor! But he for his part knows. What he says, moreover, does not go very far, but at least he knows what he is saying. On the other hand, it is a disentangling that is indispensable for you about what is involved in this little sheet of paper folded in four, that, as I already said, I already spoke about this, was found in Pascal's pockets, the dead Pascal. I speak a lot about the dead God, it is probably to deliver us from many other relationships with others that I evoked earlier, my relationships with the dead Freud; that has a completely different sense.

But if you would not mind reading this *Pascal's wager* by Georges Brunet, at least you will know what I am talking about, when I speak about this text, which is scarcely a quarto, as you know. It is a writing that overlaps, that becomes entangled, that criss-crosses, that is annotated. It was a text for the pleasure, of course, of professors. This pleasure is brief, because they were never able to get absolutely anything from it.

There is something that is, on the contrary, quite clear, and it is with this that I will begin the next time. That strictly nothing else is at stake except precisely the "I". People spend their time asking whether God exists as if it were even a question. God is, there is absolutely no kind of doubt about that, that absolutely does not prove that he exists. The question does not arise. But it is necessary to know if "I" exists.

I think I will be able to make you sense that it is around this uncertainty, does "I" exist, that Pascal's wager is played out.

Seminar 7: Wednesday 15 January 1969

(83) I announced the last time that I would talk about Pascal's wager. It is a responsibility. I even learned that there were people who changed their timetable, who came to Paris one more time than they had planned. This is to tell you how heavy such an announcement is to bear. In any case it is certain that I cannot set out here to bring you, to give an exhaustive discourse about everything that has been stated about Pascal's wager. I am obliged then to suppose that you have a certain rough knowledge of what is involved in Pascal's wager. I cannot properly speaking enunciate it again because, as I told you the last time, it is not properly speaking a statement that holds up. This is even what has astonished people: that someone who one is sure is capable of some rigour should have proposed something so untenable.

I think that I introduced sufficiently, just about sufficiently, the last time what justifies in general the use that we are going to make of it. But in any case let us not lose time in recalling it, you are going to see what this use is.

It is not the first time moreover for me to speak about it. On a certain day of February 1966, I believe, I already brought in this wager, and very precisely in connection with the o-object; you will see that today we are going to remain around this object. Already those who remember – perhaps there are some of them, I am even sure of it – what I said at that time can clearly see what is at stake. It happens that

I was asked to go to speak about it again in October 1967 at Yale. And I was so busy with the people who motivate this effort of teaching, namely, the psychoanalysts, that I missed the opportunity of speaking to the people at Yale; I did not know until much later that this created a little scandal. It is true, it was not very polite. We are going to try today to say what I could have said over there, without there being moreover any preparation at all to hear it.

But, let us begin right at the ground level, as if we were at Yale. What is at stake? In general, you must have heard tell of something that is stated and that is written several times in the text of what has been collected under the title of *Penseés*, Pascal's *Penseés*, and that at the start there is something rather risky in the use that is made of what is called the wager itself. As you know, these *Penseés*, were notes taken (84) for a major work. Only this work was never done, so it was done in his place. First of all a work was created – this is the edition of the *Messieurs de Port-Royal* – it is not at all a work that is badly done. They were pals, and as someone called Filleau de la Chaise who is not properly speaking a luminary but who is very readable testifies, Pascal had very carefully explained to them what he wanted to do and they did what Pascal had indicated. It nevertheless remains that this left out a lot of things in the statements that were written out in notes for the purposes of the construction of this work. So then others ventured on a different reconstruction. And then others said: “Since in short as our culture advances, we perceive that the discourse, is not so simple a thing as that and that in putting it together, well, there is some loss” so then people set about making editions that were called critical, but that take on a completely different import when what is involved is a collection of notes. There again there was some difficulty. We have several editions, several ways of grouping these bundles as they say; that of Tourneur, that of Lafuma, that of X, that of Z. This does not simplify things, but be assured, it certainly clarifies them.

As regards the wager, it is quite separate. It is a little piece of paper folded in four. That was the interest of what I recommended to you, it was for you to grasp this. Since, in this book there is a reproduction of the piece of paper folded in four and then a certain number of transcriptions. Because this too posed a problem given that they are notes, written freehand, with different divisions, a lot of things crossed out, whole paragraphs written between the lines of other paragraphs, and then a utilisation of the margins with references. All of this moreover is rather precise and gives ample material for examination and for discourse. But there is one thing that we can take as certain, it is that Pascal never claimed that he made his wager stand up. This little paper must all the same have been close to his heart since everything indicates that he had it in his pocket, in the same place that I have here this device, this microphone, this absolutely useless thing. In general, you have heard tell of something that sounds like *to renounce pleasures*. This thing which is said in the plural is also repeated in the plural. And moreover everyone knows that this act is supposed to be at the source of something that might be called the Christian life. It is the background noise. Through everything that Pascal and others around him tell us in terms of an ethics, this can be heard in the distance like the sound of a bell. What we have to know is whether it is a knell. In fact, it is not all that much of a knell. From time to time it has a gayer aspect. I would like to make you sense that it is the very principle on which there is installed a certain morality that one can qualify as modern morality.

To make understood what I am in the process of putting forward, I am going to give a few reminders of what is effectively involved. The (85) reinvestment, as they say, of profits, which is fundamental, this again is what is called enterprise, the capitalist enterprise, to designate it in its proper terms, does not put the means of production at the service of pleasure. Things have even got to the stage that a whole aspect of something that is manifested in the margins is, for example, an effort, a quite timid effort that does not at all imagine sailing

towards success but rather casts doubt on what can be called our style of life. We will call this an effort to rehabilitate spending, and someone called Georges Bataille, a thinker in the margin of what is involved in our affairs, has thought out and produced on this point some quite readable works that are not for all that dedicated to efficiency.

When I say that it is modern morality, what I mean by that, is a first approach to the question, that looking at things historically, this is responding to a break. In any case, there is no reason to minimise it. This does not mean either that like every historical break, one must remain with it to grasp what is involved. And it is just as good to mark its time. The search for well being (*bien-être*) – I cannot insist a lot, because our time is measured out, of course, as always, on what justifies the use of this term. But in any case all of those who follow, even from time to time, superficially, what I say ought all the same to remember what I recalled in this place about the distinction between *Wohl, das Wohl*, there where one feels good, and *das Gute*, the good, in so far as Kant distinguishes them. It is quite clear that this is one of the core points of what I earlier called the break. Whatever may be the justification of Kant's statements, one must find in them the very soul of ethics, or indeed, as I did, illuminate by its relationship to Sade. It is a fact of thinking that this happened.

We have the notion for some time that the facts of thinking have a background, perhaps something that is already of the order of what I recalled. Namely, the structure that results from a certain use of the means of production that is in the background, but, as what I am articulating this year is proposing, there are perhaps other ways of taking it. In any case, by this well-being, I am aiming at what in the philosophical tradition is called *hedone*, pleasure. This *hedone*, as it has been used, presupposes that there corresponds to pleasure a certain relationship that we will call a relationship of the right tone, to nature of which we, men, or presumed to be such, would be in this

perspective less the masters than the celebrants. It is indeed this that guides those who, let us say, from all antiquity, when they began, in order to ground morality, to take this reference point, that pleasure ought all the same to guide us along this path, that it is the original link in any case, that what is going to be at stake, is rather to pose as a question why certain of these pleasures are outside this correct tone. It is a matter then of pleasuring, as I might say, pleasure itself. Of (86) finding a module with the correct tone at the heart of what is involved in pleasure, and to see what is in the margin and what appears to function in a perverted fashion and is nevertheless justifiable with respect to what pleasure gives the measure of. Something is to be noted, which is that one can quite correctly say that this perspective involves an asceticism, an asceticism to which one can give its escutcheon which is the following: not too much work.

Well then up to a certain moment, that did not seem to do the trick. But I think all the same, all of you in so far as you are here, see that we are no longer in this atmosphere because in order to obtain this “not too much work”, we have to make a ferocious effort! The strike, for example, that does not simply consist in folding one’s arms but also of starving at the same time. Up to a certain time, people never needed to have recourse to means like that. This is what clearly shows that something has changed for so many efforts to be necessary to have “not too much work”. This does not mean that we are in a context that follows its natural incline. In other words, the asceticism of pleasure, was something that scarcely needed to be stressed in so far as morality was grounded on the idea that there was somewhere a good and that it was in this good that the law resided. Things seem to be all of a piece in this sequence that I am designating.

Otium cum dignitate reigns in Horace, as you know – or you do not know; everyone knew it in the last century because everyone worked on Horace, but thanks to the solid education that you have received in the *lycée* you do not even know what Horace is. In ours, we are at the

point when soon *otium*, namely, the life of leisure - naturally not our leisure which are forced leisures, you are give the leisure to go looking for a ticket in the Gare de Lyon, and then helter-skelter, and then you have to pay it, and then you have to transport yourself to the winter sports. There for a fortnight you are going to apply yourself to a solid *pensum*, that consists in queuing at the bottom of ski-lifts. You are not there to amuse yourself! The person who only does that, who does not work during his leisure time, is unworthy. *Otium*, for the moment is *cum indignitate*. And the further it goes, the more it will be like that unless there is an accident. In other words, to refuse to work, in our day, is something like a challenge. It is posed and can only be posed as a challenge. Excuse me for insisting again. St Thomas, in so far as he formally re-injects Aristotelian thinking - I am only saying formally - into Christianity, can only organise, even he, St Thomas, who may appear to you, like that to be a little grey faced, he can organise the Good as sovereign Good only in terms that in the last analysis are hedonistic. Naturally, this must not be seen in a monolithic fashion, if only because all sorts of misunderstandings are introduced into these (87) sorts of propositions that were already obvious even when they reigned. And it is certain that to follow their trace and see how the different spiritual directors got out of them would imply a great effort of discernment.

What I want to do is simply to recall here where we are centred by the fact that undoubtedly there has been in this respect a radical displacement. And that for us the starting points can only quite obviously be to question the ideology of pleasure through what renders everything that sustained it a little out of date. This by placing ourselves at the level of the means of production in so far as, for us, these are what really condition the practice of this pleasure. It seems to me that I sufficiently indicated already earlier how one can put on one side of a page the publicity for the proper use of holidays, namely, the hymn to the sun, and on the other side the obligatory conditions of the ski-lift. It is enough to add to it that all of this happens completely at

the expense of the simple arrangement of ordinary life and of the cankers of sordidness in the midst of which we live, especially in big cities.

It is very important to recall in order to perceive that in short, the use that we make in psychoanalysis of the pleasure principle starting from the point at which it is situated, where it reigns, namely, in the unconscious, means that pleasure, what am I saying, its very notion, are in the catacombs. And that Freud's discovery about this plays the function of the evening visitor, the one who comes from afar to find the strange slippages that have taken place during his absence. "Do you know where I found it, he seems to say to us, this flower of our age, this lightness, pleasure? Now it is panting in the underground *Acheronta*, says Freud, simply concerned to prevent everything exploding, by imposing a measure on all of these enthusiasts, by slipping into it some lapse or other, because if it worked correctly, where would we be?" There is therefore in Freud's pleasure principle, something like that, a power of rectification, of tempering, of least tension as he puts it. It is like a sort of invisible weaver that is careful that there is not too much heat in the wheels.

What relationship is there between that and the sovereign pleasure of contemplative *farniente* that we pick up in the statements of Aristotle for example? This may be of a nature – if I am coming back to it, it is not in order to be always be going around in a circle – to make us suspect that there is perhaps all the same here some ambiguity. I mean a phantasy that we must also be careful perhaps not to take too literally, even though of course the fact that it comes to us after so much drifting renders it no doubt very precarious to appreciate what it was in its time. This to correct what in my discourse, up to the point that I have got to, may seem to be like a reference to the good old days. We know that it is difficult to escape from it, but it is not a reason (88) either not to mark that we do not give it too much credence.

In any case, the presentation of pleasure, even in Freud, is struck by an admitted ambiguity, the one precisely of the beyond, as he says, of the pleasure principle. We are not going to develop things here. To be quit of it, we will say that Freud writes, "Enjoyment is fundamentally masochistic". It is quite clear that this is only a metaphor, because moreover masochism is something at a level that is differently organised than this radical tendency. Enjoyment would tend, Freud tells us when he tries to elaborate what is at first only articulated metaphorically, to lower the threshold necessary for the maintenance of life. This threshold that the pleasure principle itself defines as an *infimum*, namely, the lowest of the heights, the lowest tension necessary for maintaining this. But one can fall still lower, and that is where pain begins and can only be exalted, if really this movement, as we are told, tends towards death. In other words, behind the affirmation of a phenomenon that we can hold to be linked to a certain context of practice, namely, the unconscious, it is a phylum of a completely different nature that Freud opens up with this beyond. No doubt it is certain that here the ambiguity as I have just stated it has not failed to preserve its agency, that a certain ambiguity is profiled between this theoretical death drive on the one hand and a masochism that is only a much more astute practice, but of what. All the same of this enjoyment in so far as it is not identifiable to the rule of pleasure. In other words with our experience, psychoanalytic experience, enjoyment, if you will allow me this to abbreviate, is coloured. There is a whole background, of course, to this reference. It must be said that with respect to space with its three dimensions colour, if we knew how to deal with it, could no doubt add one or two perhaps three to it. Because from this note, you should note that on this occasion that the Stoics, the Epicureans, the doctrinaires of the reign of pleasure with regard to what is opened up to us as a questioning, this still remains black and white.

I have tried, since I introduced into our handling this function of enjoyment, to indicate that it is essentially a relationship to the body

but not an indifferent one. This relationship that is founded on the exclusion at the same time inclusion and constitutes our whole effort towards a topology that corrects the statements accepted up to now in psychoanalysis. Because it is clear that at every stage people speak only of this – rejection, formation of the non-ego, I am not going to recall all of them for you – but a function of what is called incorporation and what is expressed as introjection, as if what were at stake was a relationship of the inner to the outer and not a much more complex topology. Analytic ideology, in short, as it has been (89) expressed up to now is remarkably awkward and this is explained by the fact of the non-construction of an adequate topology.

What must be grasped is that this topology, I mean that of enjoyment, is the topology of the subject. It is what *poursoit*'s our existence as subject. The verb *poursoir* is a new word that emerged just like that. I do not see why, after all the time that we have been speaking about *en-soi* and *pour-soi* one could not construct variations. It is extraordinarily amusing, for example you could write the *en-soi* like that, *anse-oie* or again *en-soie*. I will spare you. When I am all alone I have great fun! The interest of the verb *poursoir*, is that it immediately it finds little friends, *pourvoir* for example or again *surseoir*. You have to change the spelling if it is on the side of *surseoir* you have to write *pourseoit*. The interest is that if this helps to think out things and in particular a dichotomy: is the subject pursued against enjoyment? In other words does he test himself against it? Is he carrying on his own little game in the affair? Is he master when all is said and done or is he *poursised* to enjoyment? Is he in a way dependent on it, a slave? It is a question that has its interest, but in order to advance in it, you must start from the fact that in any case our access to enjoyment is commanded by the topology of the subject. And that, I assure you gives rise to some difficulties at the level of statements concerning enjoyment.

I speak from time to time with people who are not necessarily in the public eye but are very intelligent. There is a certain way of thinking that enjoyment can be assured by this impossible conjunction that I stated the last time between discourse and formal language. This is obviously linked to the mirage that all the problems of enjoyment are essentially linked to this division of the subject; but it is not because the subject is more divided that one will discover enjoyment. You must pay very careful attention to this. In other words, the subject creates the structure of enjoyment, but as far as we know, all that one can hope from it, are practices of recuperation. This means that what he recuperates has nothing to do with enjoyment, but with its loss. There was someone called Hegel who already posed these problems very clearly. He did not write "*pour-soi*" like me, and this is not without consequences. The way that he constructs the adventure of enjoyment is certainly, as it should be, entirely dominated by the *Phenomenology of the spirit*, namely, of the subject. But the error is there from the beginning as I might say and as such it cannot but have its consequences up to the end of what he says. It is very curious that in making this dialectic start, as it is put, from the relationship of the master and the slave, it is not manifest, and in a quite clear way from the very fact that he begins with, namely, the fight to the death, for pure prestige he insists, that this assuredly means that the master has renounced enjoyment. And since it is for nothing other than for the salvation of his body that the slave accepts to be dominated, it is hard (90) to see why, in such an explanatory perspective, why he should not be left with enjoyment. One cannot all the same have one's cake and eat it. If the master has taken the risk at the start it is indeed because he leaves enjoyment to the other.

Do I have to indicate, to recall, to evoke on this occasion what the whole of antique literature bears witness to, namely, that to be a slave, was not as troublesome as all that. It spared you, in any case, many political difficulties. Please do not misunderstand. I am speaking about the mythical slave, the one at the start of Hegel's

phenomenology. And this mythical slave has his correspondents. It is not for nothing that in comedy – open Terence – the young girl destined for the final triumph of marriage with the nice daddy’s boy is always a slave. For everything to be correct and to make us look foolish, because it is the function of comedy, it happens that she is a slave but from a very good family. It has happened by accident! And at the end everything is revealed. At that point, daddy’s boy has put too much into it to be able to say in all decency “I am not playing the game; if I had known that she was the daughter of daddy’s best friend, I would never have got involved with her!” But the sense of ancient comedy, is precisely that. It is to designate to us, when it is enjoyment that is at stake, that the daughter of the master of the allotment next door, is not the one that is recommended. She has something a little bit stiff about her, she is a little bit too attached to the patrimony that is attached to her.

I apologise for where these little fables take us, but it is in order to say that what historical evolution recuperates by freeing the slaves is of a different order. It frees them from something or other. But there is one thing certain. At every stage, it links them, at every stage of recuperation it links them to *surplus enjoying* which is, as I think I have sufficiently stated from the beginning of this year, something different. Namely, what responds not to enjoyment but to the loss of enjoyment in so far as from it emerges what becomes the cause conjugated by the desire for knowledge and this animation that I recently qualified as ferocious that proceeds from *surplus enjoying*. Such is the authentic mechanism, and it is important to recall it at the moment when all the same we are going to speak about Pascal, because Pascal like all of us is a man of his time.

Naturally the wager has to do with the fact that in the same years – and on these points of the sidelights of history, trust me, I have gone through everything that can be read. I simply signal to you that my friend Guilbaud has written in the reviews, I have only the offprint but

I will try all the same to know where you can get it, some short, very short little articles that are quite decisive as regards the relationship of this wager. He is not the only one moreover. In Brunet's book the (91) thing is also dealt with. The rules of games (*la règle des partis*) are something that one should say a lot about to show you its importance in the progress of mathematical theory. You should simply know that there is nothing more up to date with regard to what is at stake, for us, when it is the subject that is at stake. To interest oneself in what is involved in what is called a game, in so far as it is a practice that is fundamentally defined by the fact that it involves a certain number of events that take place within certain rules. Nothing isolates in a purer way what is involved in our relationships to the signifier. Here, in appearance, nothing else interests us than the most gratuitous manipulation in the order of combination. To pose the question, nevertheless, of what is involved in the decisions to be taken in this field of the gratuitous, is designed to underline that nowhere does it take on more force and necessity. It is in this respect that the wager that is made in it takes on its importance, when we see that everything is lacking to it in terms of acceptable conditions in a game. The efforts of authors to rationalise it, in a way, with respect to what was in effect for Pascal the reference – but he was certainly the first to know it – and to demonstrate that it does not work, gives its value to the way Pascal's wager is handled. And there in the text of Pascal and taken up by the authors in a short sighted way that is here the most exemplary thing and of which one can say that after all the authors do us the service of showing how there is installed the impasse that they persevere in, this way of highlighting, with respect to this decision, the relationships of extension to what is at stake. Namely, on the one hand a life whose enjoyment one renounces in order to make of it, in exactly the same way as Pascal signals it in the study of what is called the rules of games, which is that when it is in play, it is lost. This is the principle of the bet, the bet on the other side, on the side of the partner, is what Pascal articulates, *an infinity of infinitely happy lives*.

I am signalling to you that here a point is opened up of whether this infinity of lives is to be thought of in the singular or the plural. An infinity of life, in the singular, does not mean very much except changing the sense that in this context, the context of the rules of games, the word infinity has. Nevertheless we are here at the mercy of the ambiguity of little sheet of paper. The word happy (*heureuse*) is not finished; why should the word life (*vie*) be complete? The 's' that may well also belong to it, the numeral aspect of a comparison promoted here, namely, the numeral relationship between the stakes, with something that has no other name than uncertainty and that is itself taken, as such, numerically. Pascal writes that with respect even to a chance of gain one may suppose an infinity of chances of loss. To introduce then as a numerical element of chance, while it was properly speaking excluded in what he stated about the rules of games, which in order to be stated involves an equality of chances, shows clearly that in any case it is on the numerical plane that the stake ought to be (92) measured.

I insist, because in this little paper, which is in no way something edited or in a definitive state, which is a succession of written signs that are made, it is moreover stated at other points that to stake what is in question, namely, the fundamental uncertainty, namely, is there a partner. At other points Pascal states "there is one chance in two", namely, God exists or does not exist, a procedure that we of course see to be rather untenable and has no need to be refuted. But can it not be seen that in this everything resides precisely at the level of uncertainty? Because it is quite clear that nothing is imposed by this calculation and that one can always oppose to the proposition of the wager "what I have I hold and with this life I already have enough to do". Pascal lays it on and he says that it is nothing, but what does that mean? No, not zero, because there would be neither game, there would be no game because there would be no stake. He says that it is nothing, which is a completely different business, because this is precisely what is at stake when it is the *surplus enjoying* that is involved. And moreover if there

is something that carries to the most essential, to the most radical point our passion for this discourse, it is precisely because this is what is at stake. The opposition no doubt still holds up. By betting in such a game, am I wagering too much?

And this indeed is why Pascal allows it to be inscribed in the argumentation of his supposed contradictor, a contradictor who moreover is nowhere except in himself because he is the only one to know the contents of his little piece of paper. But he answers him: "You cannot not wager because you are engaged". And in what way? You are not at all engaged except if the fact that you have to take a decision dominates. Namely, what is in the game, in games theory as it is called in our day, which is only the absolutely direct continuation of what Pascal inaugurated in the rules of games where decision is a structure. And it is because it is reduced to a structure that we can manipulate it in an entirely scientific way. Only there, at this level, if you have to take a decision, whichever of the two it may be, if you are engaged anyway, it is from the moment that you are questioned in this way, and by Pascal. Namely, at the moment that you authorise yourself to be "I" in this discourse. The veritable ambiguity, the dichotomy is not between God exists or does not exist, whether Pascal likes it or not. The problem becomes of a completely different nature from the moment that he affirmed we do not know, not whether God exists, but neither whether God is, nor what he is. And therefore the business about God will be – our contemporaries have perfectly sensed it and have articulated it – a matter of fact, which, if you refer to the definition that I gave of fact, is a matter of discourse. The only fact is one that is stated. And that is why we are entirely given over to the tradition of the book. What is at stake in Pascal's wager is the following. Does "I" exist or whether "I" does not exist, as I already (93) told you, at the end of my previous discourse. I have spent a time that was as it happens and perhaps I am a little bit too used to doing this, too much time introducing the core of what is involved, but I think that these premises were indispensable. This leads me then in a

not particularly timely way to our cut today. You should know simply that contrary to what is believed, the wager is not on the promise but on the existence of the "T", something that can be deduced beyond Pascal's wager. Namely, if we put in its place the function of the cause as it is placed at the level of the subject, namely, the σ -object. It is not the first time for me to write it thus, σ -cause. It is precisely in so far as the whole wager has this essence of reducing this thing that is all the same not something that we can, like that, hold in the hollow of our hands, namely, our life of which after all we may have a completely different apprehension, a completely different perspective. Namely, that it comprehends us and without limit, and that we are here a place of passage, a phenomenon. Why should this not be sustained? It has been after all.

That this life should be reduced to this something that can thus be brought into play, is this not the sign that what dominates in a certain rise of the relationships to knowledge, is the σ -cause. And it is here that in our subsequent steps we will have to measure what results, beyond this σ -cause, in terms of a choice. To say *I exist σ* , with regard to this relationship to the σ -cause, a whole succession of consequences perfectly and immediately formalisable. I will do a calculation of it for you the next time. And inversely, the very fact of being able to calculate in this way the other position, the one that speaks in favour of seeking what is involved in the *I* that perhaps does not exist, goes in the direction of the σ -cause, in the sense of what Pascal proceeds to when he invokes his interlocutor to renounce it, here for us there takes on its sense, the direction of a research that is explicitly ours, as regards psychoanalysis.

Seminar 8: Wednesday 22 January 1969

The most difficult thing to think about, is the One. That people strive to do so is not new. The modern approach is scripturist (*scripturaire*).

There was a day when I extracted, to the astonishment, I remember, of one of my listeners who marvelled at it. "Ah! How did you manage to get your hands on that, *einzigster Zug*", which I translated in a way that has lasted as the unary trait. It is in effect the term with which Freud pinpoints one of the forms of what he calls identification. I showed at that time in a sufficiently developed way for me not to have to come back to it today, except simply to recall that in this trait there is the essential of the effect of what for us analysts, namely, in the field that we have deal with the subject, is called repetition.

This thing, that I did not invent, but which is said in Freud, provided only one pays attention to what he says, this is linked in a way that one can call determining to a consequence that he designates as the lost object.

Essentially, to summarise, it is in the fact that enjoyment is aimed at in an effort of rediscoveries and that it can only be so by being recognised by the effect of the mark, that this mark itself introduces into it a blemish from which this loss results. A mechanism that is fundamental and essential to confront with what already appeared in a research that, after all, was pursued along the same path, concerning every essence and culminated at the idea, the pre-existence of every form and at the same time by appealing to this thing that is not easy to think out. This is Plato, it is reminiscence.

These points having been recalled, we are dealing with Pascal's wager. Its relationship to repetition, I think, is not altogether unnoticed by many of you who are here. Why am I now going through Pascal's wager? It is certainly not in order to sound clever, nor as a philosophical reminder, nor of the philosophy of the history of philosophy. What happens at the level of Jansenism, to recall the Pascalian context, is an affair that interests us precisely in this that the historian, as in many other things, is quite incapable of finding his bearings in it.

Read a little *Que-sais-je?* I apologise to its author for having forgotten his name, but I read the text from beginning to end, and naturally not to inform myself about Jansenism. Besides I will not say anything more about what is involved in my relationship to it, it would be too good an opportunity for you to precipitate yourself into the historical or (96) biographical determinations of my interests. In any case, some time ago, as it happens, I was able to get a grasp of it outside this sort of ghost that remains of it, namely, that they were people that are called rigorist, in other words who prevented you from living the way you wanted to. That is all that remains of it in effect, through one of these surprising effects of silting up that it must not be forgotten is also a dimension of history. But in reading this little book then, I was getting the testimony about what is said of it, simply by taking things precisely as the title of the collection indicates, at the level of *Que sais-je?* The author knows a lot of things. He starts from the origin, if indeed there was one, of the questions it gives rise to. He ends up at the point where it is drowned in the upheavals of the French Revolution, and he very nicely admits at the end that in the last analysis, you cannot really see, taking everything into account what Jansenism meant. Which is all the same, for a work of historical review, a rather curious but exemplary conclusion.

One thing appears in this history. It is that in taking it at the level of its historical recording, it begins as an affair among theologians. And moreover it is quite true that Jansenius is found to be the most

representative of them, let us even say the most worthy to represent them, if only because of this exemplary thing which is that it appears that everything that was being stirred up at the epoch around the debate, about the contradiction and condemnations that followed it, the fundamental question, the one that almost none of the participants in the debate does not bring up, is: "And first of all you have not read him!" And it seems indeed in effect that the very great majority of those who were so passionate at that time, not only had not read him but had not even opened him. Some however, the two or three leaders, the Grand Arnaud must have read him; moreover was there any need to read him? People had read a lot of other things that were fundamental and in particular - before, well before this work that appeared posthumously, as you know perhaps, that is called *Augustinus*, by the person that I have just named, Bishop Jansenius - there was the thinking of St Augustine that one cannot deny is at the foundation of Christianity. In a word, the question is obvious once it is precisely Christianity that is at stake.

The measure in which Christianity interests us, I mean at the level of theory, can be measured precisely by the role given to Grace. Who does not see that Grace has the closest relationship with the fact that I, starting from theoretical functions that certainly have nothing to do with the effusions of the heart, designate as $d(O)$, the desire of the Other. Man's desire, I said at one time when, to make myself understood, I had to risk certain improbable words like Man, for example. I could have contented myself with saying, desire as it concerns you, this desire operates in the field of the Other in so far as it is articulated as the locus of the word. Who does (97) not also see what is implied, if what is stated here is correct, this relation orientated by the vector starting from $\$ \diamond D$ on the graph towards this desire, the desire of the Other to question it in an "I ask myself what you want" which is also balanced by an "I ask you what I want". Anything that tends in any manifestation of desire towards a "Thy will be done" deserves to be posited first of all, in any judgement - it is not necessarily the privilege of spiritual people - about what is the nature of

prayer. Its inextricable intermeshing with the functions of desire could be clarified from it.

This *tutoiement*, [Thying], I have said, does not have a simple start, because at the level of the subject, the question of who is speaking remains intact. It is nonetheless essential to note that this Thy is addressed to a faceless Other. There is no need for him to have one at all for it to be addressed to him, if we know how to distinguish this field of the Other from the relationship to one's fellow. Now this is precisely what articulates its definition in my theory. The relationship, the knot, the link between the disputes about Grace, which it seems that those responsible by right, namely, the Church, at the time that we are speaking about, could not get out of in any other way except by prohibiting in a repeated fashion for two centuries that anything whatsoever should be articulated either for or against in this debate. This prohibition of course only made the struggle rebound and multiply the books and the pamphlets. This is something in which what concerns us is that this frenzy that some people say is purely intellectual is completely solidary to a movement whose incidences of fervour there is no question of contesting. Nor in this case the properly convulsive effects. And this was pinpointed at the time. However we may be able to gauge as psychopathological what happened on the tomb of a certain Paris deacon. And when, the doors were closed at the entrance of the cemetery, so that there could be written over them *By order of the king God is prohibited from doing miracles in this place* the aforesaid convulsions continued elsewhere. It seems that even if it were only to pinpoint things in this ultimate consequence, we can see that this field is close to our own. And that after all, to take it in a way that is not altogether at basic, namely, "should they be interned or not?" we have all the same the right to try to articulate something and why not, in the freest, the most lucid, the most speculative way about the wager precisely of Pascal.

The *Name of the Father* – I am going to announce it like that at the start because it will perhaps be the best way to detach you from the effort of

fascination that emerges from these confusions – the *Name of the Father*, that I am insisting on to say that it is not by chance that I was not able to speak about it, the *Name of the Father* takes on here a singular form that I am asking you to carefully locate at the level of the wager. This will change for you perhaps the haggling that the authors on this subject have usually devoted themselves to about whether it is worthwhile to wager. (98) What is worthwhile, is to consider how it is formulated from the pen of Pascal. I would say that this singular form, in the statement of what comes at the top of this little paper, this singular form is what I would call the absolute real; and the absolute real, on this little paper, is what is stated as heads or tails. Heads or tails (*croix ou pile*), it is not a matter of the cross, you can get that out of your heads. “*Croix ou pile*” was the way at the time of saying what we would call today heads or tails.

I want you to get the idea that if it is conceivable that we should arrive, at some point, at the final term of any science whatsoever in the modern sense, namely, by the operation of what is called a measure, it can only be very precisely at the point when what is to be said, is “heads or tails”, “it is that or it is not that”. It is what it is, there, because up to then, nothing confirms for us that we are not just measuring our own measures. It must come to a point, heads or tails, at which it is only the real that is involved as a check.

Pascal’s wager contains at its start something that is referred to this pole point, the absolute real. And this all the more in that what is at stake, is precisely something that is defined: that we cannot know *either whether He is or is not*. This is explicitly what Pascal articulates as regards what is at stake, which of course, at the level of the wager, if the question of its act is posed, may well in effect be expressed by the question of the existence or not of the partner.

But there is not just the partner. There is the stake. And this is the interest of Pascal’s wager. The stake, the fact that he can pose in these terms the question of our measure with respect to the real, the stake

supposes that a step has been taken that, whatever the amateurs of historical ferreting out may say, namely, that already Raymond Sebond, Père Sirmond and Pierre Charron had brought up something of the order of this risk. Overlooking that if Pascal can advance in a fashion that makes it not at all a matter of chance that it has been so profoundly felt in the field of where it thinks, it is because he profoundly modified the approach of what is involved in the "I say", I mean of the I of the gambler. And this by proceeding as I might say to something that might be called an exorcism, the day he discovered the rules of games.

The resistances he encounters after having posed the problem of the just way to divide up the stake when, for some reason or other, necessary or by mutual consent, an interruption takes place during a game whose rules had already been given, the pivot of what allows him to settle it in such fruitful way, that it is through this that he articulates the foundation of what is called the mathematical triangle. This assuredly, of course, had already discovered by someone called Tartaglia. But he did not necessarily have to know that, moreover, besides, he draws different consequences from it. Because it is through it that he rejoins, takes up again and gives a new push to what, in the laws of the maximum and the (99) minimum in Archimedes, a prelude to what is going to be born from integral calculus. All of this rests on this simple remark, to settle what is at stake, which is that the essence of the game, in what it involves in terms of logic because it is regulated, depends on the fact that what is bet is lost at the start. While the question of the lure of gain distorts, refracts, in a way that does not allow theoreticians not to be weakened in their articulations, this initial purification allows there to be stated in a proper way what has to be done in order to carry out at every moment a sharing out of what is there at the centre as stake, as lost.

The question is interesting for us analysts, because it allows us to attach to it the essential motivation for the emergence of such a concatenation. If there is an activity whose starting point is grounded on the assumption of loss, it is indeed because what is at stake in the very approach of any rule -

namely, of a signifying concatenation, of an effect of loss - is very precisely what I have been trying to dot the i's of from the beginning. Because of course our experience, as they say, in analysis confronts us at every instant with this effect of loss. And if one does not grasp what is at stake, one attributes it, under the name of narcissistic wound, to an imaginary injury. This is how innocent experience testifies that this effect of loss is met with at every step. It bears witness to it in an innocent way, namely, in the most harmful way, by referring it to this schema of narcissistic wound, namely, from a relationship to one's fellow that on this occasion has absolutely nothing to do with it. It is not because some fragment that is supposed to be part of the body is detached from it that the wound in question functions, and every attempt at reparation, whatever it may be, is condemned to prolong its aberration. What is at stake, the wound, is elsewhere in an effect that at the start, to recall it, I distinguished from the imaginary as symbolic. It is in the gap that is produced or aggravated, because we cannot plumb how much of this gap was already there in the organism, of this gap between the body and its enjoyment. In as much as then, as I have said, what determines it or aggravates it, and it is only this aggravation that is important, is the incidence of the signifier. The very incidence of the mark, the incidence of what I earlier called the unary trait, which gives it its consistency.

So then what is at stake is outlined by measuring the effect of this loss, of this lost object in so far as we designate it by o , at this locus without which it could not be produced, at this still unknown, still unmeasured locus called the Other. What does it mean, that one must first take this measure of which it is enough to have the experience, indeed the passion for gaming to see its relationship with the way we function as desire. What is going to be involved between this proportion that we must now (100) measure? Well then, there is something very strange. This proportion, this measure, is already there in the figures, I mean in the written signs with which we articulate the very idea of measure.

We do not know anything, at this point, about the nature of the loss. I can behave as if we never give it any particular support. We give points, I will not say where we are able to scoop things out, where we get the wood shavings; but there is no need to know. As I said, on the one hand we only know the function of loss and on the other, we undoubtedly do not know what is involved in the 1 because it is only the unary trait. This *not knowing* is only what we are happy to retain of it. And nevertheless it is enough for us to write $1/o$ in which the proportion is inscribed. Namely, that the relationship of this 1, determining for the effect of loss, is equal and should be, since it seems indeed that it is a loss that is at stake, to something in which there is connected by an additive "and" this 1 and the written sign of this loss, $1/o = 1+o$. Because such indeed in effect is the inscription from which there results what is involved in a certain proportion whose harmony, if it must be evoked, does not depend assuredly on aesthetic effects. Simply I would ask you, in order to measure it yourselves, to allow yourselves to be guided first of all by the examination of what is involved in its mathematical nature. The harmonies in question are not constructed by luck, from a lucky encounter. As I think the bringing together of the series that results from the recurrent function generated from this equality, as I think I can show you that one finds in it the characteristic note, that of o , in a whole other series generated from another starting point, but which interests us just as much. As you will see, it is the one that by taking things from another end would be generated from what we have called the *Spaltung* or the original division of the subject, in other words from efforts to make two disjointed units connect up. This is a field that must be gone through step by step.

It is necessary to write out in a clear way what is involved in the aforesaid series. We write it in the following form. We put here the o and here the 1, a direction, this direction only exists, I underlined it in passing, from the fact of our starting point. After the 1, we put $1+o$. After the o , $1-o$. The series is generated from the addition of two terms in order to produce the following term. So here we have:

o	1
1-o	1+o
2o-1	2+o
2-3o	3+2o
5o-3	5+3o
5-8o	8+5o

(101) from which you can see that it does not fail to present some relationships with the opposite list. I pass on, I pass on because it is easy for you to check the fact that the continuation of these values represents a proportion that is maintained, namely, that 1+o is to 1 as 2+o is to 1+o. It is very exactly what is written in the initial formula. This might just as well be written:

$$1, 1/o, 1/o^2, 1/o^3, 1/o^4, \text{ etc....}$$

a number that, since o is less than 1, will keep on increasing.

Here on the contrary you write o^2, o^3, o^4, o^5, o^6 a number that as I repeat since o is less than one, will always decrease.

Let us not leave our Pascal because, on the little paper where what he is working on is an articulation, therefore there is no need for it to be destined for someone else in order for the exchanges to have a value that is not persuasive but logically constructive. People have seen very clearly in our day that, for certain problems, there is a way to resolve them where the number of attempts counts. Namely, at the end of how many attempts one party has the last word. If he wins because of what one could call, but purely retrospectively, a mistake by the other party, it is clear that the test will consist in connection with the other party in a more risky response.

But that, if the result is the same we can attribute to a logical articulation, I mean one that is accepted. It is enough to define it at the start, by way of a demonstration, which would be articulated as follows:

o	1
$1-o=o^2$	$1+o=\frac{1}{o}$
$2o-1=o^3$	$2+o=\frac{1}{o^2}$
$2-3o=o^4$	$3+2o=\frac{1}{o^3}$
$5o-3=o^5$	$5+3o=\frac{1}{o^4}$
$5-8o=o^6$	$8+5o=\frac{1}{o^5}$
...	...

o	1	
$(1-o)o^2$	$(1+o)$	$\frac{1}{o}$
$(2o-1)o^3$	$(2+o)$	$\frac{1}{o^2}$
$(2-3o)o^4$	$(3+2o)$	$\frac{1}{o^3}$
$(5o-3)o^5$	$(5+3o)$	$\frac{1}{o^4}$
$(5-8o)o^6$	$(8+5o)$	$\frac{1}{o^5}$
$1+o$	1	∞

It is a pity that people forget at an epoch, ours, which has very well been able to codify the laws of this function of yes or no, refutable yes or no, and to notice that it opens up a greater field than the pure and simply demonstrable. It is in this way - I pointed it out, I already announced it, initiated it the last time - that Pascal's process, the one that first of all made him sound out with regard to a pure "heads or tails" what is rational in the engagement of betting something in life which is precisely not defined against something that is at least an infinity of lives qualified, without specifying what they mean, as indefinitely happy. But perhaps it would be worthwhile, if we come after him, for us to re-question the (102) signs. We see that they are capable of delivering up something that necessarily specifies the sense.

This indeed is what we are in the process of carrying out at the level of these signs. And we perceive that if we lay hold of the o whose value we still do not know but only what it generates as a series in its relationship to 1, we see a series, nothing more. And one might even say that the question of what is involved in o and 1 as such, as terms set up in some way or other, even mathematically, does not have a sense. It is not like when it is a matter of defining whole numbers and what one can do with them, neutral elements. This 1 has nothing to do with the 1 of multiplication. Supplementary actions are necessary to put them to use. Nor is the o . The o and the 1 are everywhere, everywhere there is the relation of $1/o$, namely, in the whole series. This is precisely the interest of starting from it because the only reason that requires us to start from it is that it is starting from them that we write. In any real whatsoever that appears to correspond to this scale, they have nowhere a place. Only without them we would not be able to write this scale. It is starting from it, from this scale, that I can allow myself to image, starting from another writing, also the most simple, we remain, it seems, within our limits, within those of the unary trait. Except for the fact that we are going to prolong it indefinitely, to try at least to prolong it indefinitely.

Here is the o , here is the 1. We are not obliged to measure them for them to be correctly written. Here also, I think that you will excuse me for abbreviating and for saying that we project this o onto this field considered in its function as 1. What we have just written indicates to us that what will be here will be o^2 . The folding back of the o^2 gives us here an o^3 ; the folding back of o^3 gives us here an o^4 . I hope you are following. You see then that there is going to be added together by operations that go in a certain direction all the even powers of o : o^2, o^4, o^6 . And that here there are going to be reproduced, because if we refer the o , we will have o^5 , the sequence of the odd powers o^3, o^5, o^7 .

$$\begin{array}{c} \leftarrow \quad \quad \quad \rightarrow \\ \text{0} \quad \quad \quad \text{1} \end{array} \quad \left\{ \begin{array}{l} 1 = 1 \\ o = 0.618 \end{array} \right.$$

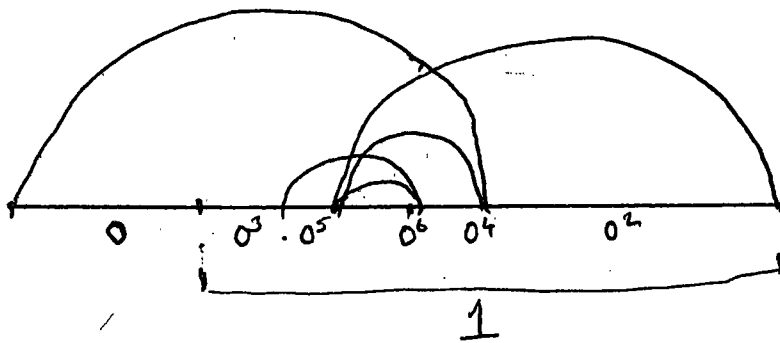

[Reconstructed
Schema based
on LACAN'S
Commentary]

(103) It is very easy to see that in this way, we will find at the converging meeting point of these powers, one even the other odd, the measure of o as a total for all the even powers, o itself being of course excluded. The measure o^2 as a sum of all the odd powers of o , o^2 and o giving a total of 1. Namely, that it is by this very operation of separated addition of even powers on the one hand and odd powers that we effectively find the measure of this field of the Other as 1, namely, something different to its pure and simple inscription as unary trait.

$$\begin{array}{r} o^3 \\ o^5 \\ o^7 \\ \hline o^2 \end{array} + \begin{array}{r} o^2 \\ o^4 \\ o^6 \\ \hline o \end{array} = 1$$

I only obtained this result by taking in isolation the proportional foundation of o . But if I take its development in the sense of growth, you easily see that by simply adding these already growing powers, if I were to tell you what this gives, at the moment that we can add the $1/o$ to some power until there has emerged o^{100} . It is very easy to make a calculation, if you have a page, and this takes no more than ten minutes, not about

what $1/0^{100}$ is but the addition of the whole series. There are very well known and very easy formulae one can see that it is 2,000,000,000,000,000,000,000,000,000.

I mean that in effect, in a sense, we find what? Nothing more wonderful than a series including a growth that is called infinite of whole numbers, but that is all the same in the final analysis of the order of what is called numerable. A series constituted in this way, which is called a geometrical progression, in other words described as exponential, remains numerable.

When I pointed out to you that it is only in a scripturist way that the point where the 1 and the 0 lies is important for us, this is not to neglect its incidence now and to say that it is starting from some points that we see a difference. The decreasing infinity is the same in its generation. Only it culminates, instead of culminating at infinity since all the same we know a little bit more about infinity and we have learned to reduce this infinity of whole numbers to its proper and distinct value. Only on the other hand, as I showed you here, by beginning from there, because this has its interest, you will have a limit, a limit that the series can approach as closely as possible, in a way less than any size that is chosen, however small it may be, namely, very precisely $1 + 0$.

The starting point of Pascal who in his notes writes simply *infinity-nothing* is in effect exactly the point where there lies at once his sureness (104) of touch and the really functional point from which everything that follows is determined. Because what he calls *nothing*, as moreover he indicates in the most explicit fashion in other notations of his, is simply that starting from a point, besides I told you any one whatsoever, we obtain in one direction, the decreasing direction, a limit. But it is not because it has a limit that it is less infinite. On the other hand what we obtain on the other side, namely, a growth that, for its part, has no limit, this does not specify this direction as more specifically infinite. Moreover, when Pascal writes *nothing*, it is not by chance; he himself suspects, that nothing is not nothing, that it is something that can be put on

the scales, and very especially at the level that we have to put it in the wager.

But here does there not appear something, something that must be seen, that in the final analysis, if in the field of the Other there is stated a revelation that promises us, I repeat, an infinity of infinitely happy lives, I am sticking to their numerical statement. And for a while Pascal sticks to it also. Because he begins to ponder, one life against two lives, is that worth the trouble? But yes, but yes, he says; against three lives, still more; and naturally the more of them there are the more worthwhile it is!

Only we see this important thing, which is that in all the cases that we choose even when it is *nothing* that we lose we are deprived of a semi-infinite. This corresponds to the field of the Other and in the way that we can precisely measure it as 1 by means of the loss. As regards the genesis of this Other, if it is true that we can distinguish it from the 1 before the 1, namely enjoyment, you see that by having affirmed the $1 + o$, by having done the addition of it with infinite care, it is indeed about o in its relation to 1, namely, about this lack that we have received from the Other as compared to what we can build up as the complete field of the Other, it is from there, from the o , and in an analogical fashion that we can hope to take the measure of what is involved in the 1 of enjoyment with respect precisely to this sum that is supposedly realised.

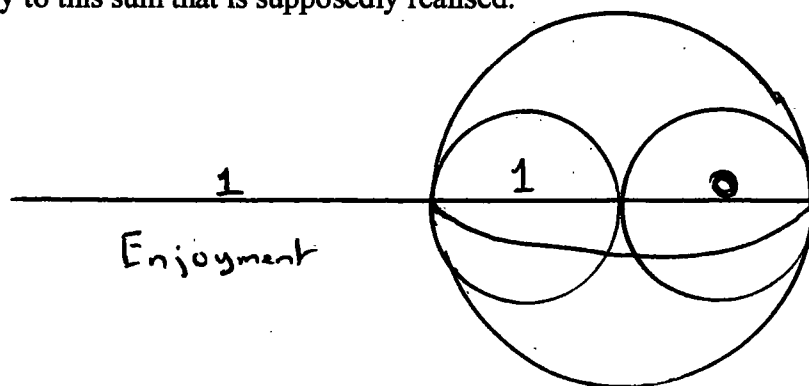

(105) We know that; we find that again, we analysts. The most characteristic, the most subtle form that we have given of the function cause of desire, is what is called masochistic enjoyment. It is an analogical enjoyment, namely, that at the level of the *surplus enjoying*, the

subject takes on in a qualified fashion this position of loss, of waste product that is represented by *o*. And his whole effort is to constitute the Other as the field simply articulated in the style of this law, of this contract which our friend Deleuze has so happily emphasised to supply for the trembling imbecility that reigns in the field of psychoanalysis!

It is in an analogical way and by playing on proportion that there steals away what is approached about enjoyment along the path of *surplus enjoying*. It is through this point, at least that by tackling things along the starting path that we have taken, we see here that we have a way in that experience justifies. The question no doubt is not without interest as regards the way a certain renunciation functions in Pascal. But do not go too quickly. To treat those who have struggled with this logic without knowing it as universally masochistic, this is the order of short circuiting where there is designated what I called in this field blackguardism that turns into stupidity.

Today I was only able to lead you to the following approach: the proportion already inscribed in the simple entry into a field along the simple scripturist path. We have of course to verify it from other angles. If this *o*, I have said - and this is even, I underline, the image, the illustration and nothing more - is what conditions the distinction of the "I" as sustaining this field of the Other and being able to totalise itself as a field of knowledge, what has to be known, precisely, is that by being thus totalised, it will never reach the field of sufficiency that is articulated in the Hegelian theme of *Selbstbewusstsein*. Because precisely in this measure and in the very measure of its perfection the "I" of enjoyment remains completely excluded. What is important for us, is to confirm that not alone would no addition of one to the other not add up in the form of any figure whatsoever, of an added 2, this divided "I" finally connects up with itself. What is most piquant at this point, is to notice, as I will show you the next time, because this field, as you see, far from being interminable is simply long and I need time to articulate it for you, anyone between now and then, and I must say that I hope that there are a good

number who will not need to do it, informs himself about what the Fibonacci series means will obviously be better prepared than the others for what I do for the others. That is, explain to them, namely, and it is very important, that a series constituted by the simple addition of 1 to 1, then of this last 1 to what precedes it to constitute the third term, in other words 2, then $1 + 1 = 2$, $1 + 2 = 3$, then $2 + 3 = 5$ etc. 1, 1, 2, 3, 5, 8, 13 etc. You can note in passing that these numbers are already inscribed and (106) that it is not without reason, only the relation of each of these numbers to the other is all the same not the 0 relationship.

I will start the next time from this fact that in the measure that they grow, namely, for any Fibonacci series – all the Fibonacci series are homologous – you can start from any number whatsoever and make it grow by any number whatsoever, if you simply observe the law of addition, it is a Fibonacci series and it is the same one. And whatever it may be, if you make it grow, you will obtain between these numbers these proportions that are already inscribed, namely, the relationship of 1 to 0. And you will notice that it is from 0 as it was in relationship to 1 that the number leaped from one term to the other. In other words, whether you start from the division of the subject or whether you start from 0, you will notice that they are reciprocal.

I wanted to leave you here, on this approach that I am calling that of pure logical consistency. This will allow us to situate better what is involved in a certain number of human activities. That the mystics should have attempted along their path this relationship of enjoyment to the 1, is not a field that I will be tackling here for the first time. Because already in the first years, the obscure times of my seminar, I put forward for you then, for those who were there, three or four, Angelus Silesius. Angelus Silesius is a contemporary of Pascal. Try to explain what his verse means without having his distichs. *Le Pèlerin Chérubinique*, I recommend it to you; you can buy it at Aubier, it is not out of print!

What is involved in it, certainly, does not directly concern our path. But if you want to see the place that the *I*, the *Ich* holds in it, you will see that it refers back to the question that is here our real goal and that I am repeating at the end today, do I exist (*est-ce que j'existe*)? You see how an apostrophe, is enough to falsify everything. If I say, I exist, that's it, you believe it, you think that I am talking about me, simply because of an apostrophe. Does it exist, speaking this time about the "I". But this it, ough! Third person, we have said that it was an object. There we are making an object of the "I". Simply by omitting the third person, that can be used also to say *it is raining*. You do not talk about a third person, you do not say "he is raining", it is not your pal that is raining. It is raining. It is in this sense that I am using *it exists*. Is there something of the "I" (*du "Je"*) that exists?

Seminar 9: Wednesday 29 January 1969

(107) I left you the last time rather firmly advanced into the field of Pascal's wager at the point punctuated by what I have just written on the board. Namely, on the remark about the essential identity of the series that I told you we place at a starting point situated between 0 and 1 in a completely arbitrary way. Arbitrary takes on its sense with the same accent that de Saussure gives this word when he talks about the arbitrary character of the signifier. I mean that at the point that we have placed the cut between a series decreasing to infinity and an increasing series, in the same way we have no reason to situate this point except from writing. Namely, that here the 1 has no other function than that of the trait, of the unary trait, of a stroke, of a mark. Only, however arbitrary it may be, it nevertheless remains that without this 1, this unary trait, there would be no series at all. This is the sense that must be given in de Saussure – an author who is no doubt super-competent declares that I betray him at my pleasure – that without this arbitrariness, language would not have, properly speaking, any effect.

So then, this series is constructed on the fact that each of its terms is produced by the addition of the two terms that precede this term. This is the same as saying that in the other direction, each is made up of the subtraction of the smaller of the two that follow it from the greater. It is constructed on the principle that the relationship of one of these terms to the following is equal to the relationship of the following one as it is produced by being added to it, which seems to add a second condition to it. To posit that the 0, the term I have just spoken about, is equal to the following 1, in its relationship to what again is going to follow it, namely, to the addition of this 1 to 0, seems to specify this series by a double

condition. Now, this is precisely what is erroneous as can be seen by the fact that if you posit as a law of a series that each of its terms should be formed from the addition – no doubt the function of addition here deserves to be specified in a more rigorous fashion but since it is not a matter here, in this connection, of me having to go into extensive considerations about what is involved in set theory, we will stick to the operation commonly known under this term and which is already, moreover, given at the source of what we have posited, at the source of this series, I mean the first one.

Here then is the series 1, 1. It is enough to establish it to write that in this (108) series U_0 will be equal to 1, that U_1 will be equal to 1 and subsequently that any U_n will be the sum of U_{n-1} and of U_{n-2} . This series is called the Fibonacci series and you see that it is subject to a unique condition. What is going to be produced in this series demonstrates that it is essentially the same as the series first posited. Namely, that if you operate between them by any defined operation whatsoever, if you add for example term to term, if you multiply term to term, also for example, you can also take other operations, there will result another Fibonacci series. Namely, that you confirm for yourself that the law of its formation is exactly the same, namely, that it is enough to add two of its terms to get the following.

What becomes then of this marvellous proportion, this ϕ that seems, in the series that I started with, that you can decorate as you know with the function of the golden number that, in effect, appears there, from the beginning under the form of this ϕ , manifested here by the fundamental position of ϕ : $\phi = 1/1 + \phi$. This little ϕ is not missing in any Fibonacci series, for the following reason. If you make the relationship of each of its terms to the following term, namely, $1/1$ first of all, that I did not write because $1/1$ means nothing, then $1/2$, then $2/3$, $3/5$, $5/8$, you will obtain a result that very rapidly tends to inscribe the first two decimals, then the three, then the four, then the five, then the six, of the number that corresponds to this small ϕ . And it does not matter that it is written as

On the Board

1 1 2 3 5 8

0

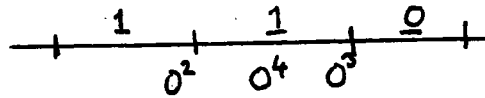

1 - 0	=	0 ²	1/2
2 - 1	=	0 ³	2/3
2 - 3 - 0	=	0 ⁴	3/5
5 - 0 - 3	=	0 ⁵	5/8
5 - 8 - 0	=	0 ⁶	8/13
13 - 0 - 8	=	0 ⁷	13/21
13 - 21 - 0	=	0 ⁸	"
	"	"	"

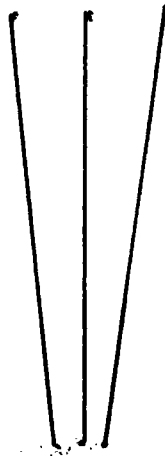

Enjoyment	1 + 0
surplus of enjoyment	1
<u>0</u>	

$$0 = \frac{1}{1+0}$$

False { enjoyment - subject
subject - divided subject

$$1+0 = \frac{1}{0}$$

S (S̄)

$$0 = 0.618$$

S (S → S')

1 (2)

0.618 and what follows, something that is very easy to verify. We already knew that ϕ was less than unity and that the important thing is that we see that this ϕ very quickly, once you get away from the starting point of the Fibonacci series, is going to be inscribed as a relationship of one of its terms to the following term. This to demonstrate that there is not in the choice of ϕ , that we have precisely because it is placed before the problem of the represented command, which is lost in the position, in the fact of posing the inaugural 1 as reduced to its function of mark, this choice of ϕ for its part, has nothing arbitrary because it is in the same way as the loss that we are aiming at, that which, at the horizon, at the goal of our discourse, constitutes *surplus enjoying*. Like this loss, the ϕ , the limiting relationship of a term of a Fibonacci series to the one that follows it, like this loss the ϕ is only an effect of the position of the unary trait.

Besides, if something is necessary to confirm this for you, it is enough for you to look at the decreasing series as I have written it, or rather rewritten it, because I already wrote it the last time on the left. It is enough for you to see how it is constructed. The series of numbers that constitute the Fibonacci series appears there in an alternating fashion, namely, that there is here an ϕ , 3 ϕ , 5 ϕ , 8 ϕ and that as regards whole numbers, they also alternate 1, 2, 3, 5, 8, 13.....it is in an alternating fashion that what is written as whole number is at the right and then on the left and so on.

(110) In the same way as regards what is involved for the number that is affected to ϕ ; but as you see, the ϕ has always here an advance on the whole number. It is 1, here, while the whole number will only be 1 at the following term and so on. That is why it changes places because, for a positive result to be maintained, and what is involved in this series, so that each of its terms should be written in a positive fashion, it is necessary that there should pass alternately from one side to the other what is numbered as a whole number and what is numbered as ϕ . Now, as you see, since ϕ is less than 1 and because we know on the other hand, because of the position of this first equality that it is going to be expressed by a growing power of ϕ , the result of this difference is going to become

smaller and smaller with respect to something that it constitutes as a limit. This is what is called a converging series and converging towards what? Towards something that is not 1 but, as I showed you the last time by the image of the folding back of this o onto the 1, then of the remainder which was o^2 onto the o , which produces here o^3 , the o^3 being folded back, which produces here o^4 , the whole arriving here at a cut that produces $o/o^2 = o + o^2 = 1$.

It is because of this that the limit of the converging series inscribed here is placed at the level of $1 + o$, itself equal to $1/o$. What does that mean? What is represented, properly speaking, by what is functioning here? The question of how it is possible to correctly represent what is involved in a possible conjunction of the division of the subject in so far as it would result from a rediscovery of the subject. Here, a question mark as regards this subject. What is involved in the absolute subject of enjoyment and the subject that is generated from this 1 that marks it, namely, the point of origin of identification. There is a great temptation to put forward the writing of the Hegelian *Selbstbewusstsein*, namely, that the subject being posited by this inaugural 1, has only to connect up with its own figure *qua* formalised. The subject of knowledge is posited as knowing itself. Now, it is precisely here that the fault appears, if it is not seen that this can only be effective by positing the known subject, as we do, in the relationship of the signifier to another signifier. This shows us that here it is the relationship not of 1 to 1 but of 1 to 2 that is at stake, and that therefore, at no moment is the original division abolished.

It is only at the horizon of an infinite repetition that we can envisage the relationship, here simply imitated, as something that corresponds to this relationship of 1 to 1, the subject of enjoyment as compared to the subject established in the mark whose difference remains irremediable since, however far you push the operation that this reduction generates, you will always find between one term and the other and inscribed as the result of the loss, the relationship that you start from, even if it is not inscribed in the original inscription, namely, the o relationship. This is all the more

significant because it is a matter precisely of a relationship and not a simple difference that, in a way, will become more and more negligible with regard to the pursuit of your operation. So that if, as it is easy to (111) verify, you take this operation in the sense of the increasing series here, the difference between the whole numbers, namely, between what is inscribed in 1, the foundation of the original subjective identification and the number of 0 will always continue to increase because here, in the direction of the addition, it is always from the relationship of a number of 0 that corresponds to the smallest term to a number of whole numbers that correspond to the greatest term that is at stake. Namely, with respect as I might say to an extension of the whole numbers of the subject, taken at a mass level, there will always be a greater lack of 0 units. There will perhaps not be 0 for everyone. Take this, I am passing on, I will come back to it perhaps in an apologue question. What is important for us undoubtedly, what is going to count in our plumbing of Pascal's wager is what becomes of it in the sense that, in a no less infinite fashion, the 0 can be approached. That once more there appears to us what gives in an analogical form what is involved in the relationships of 1 to $1 + 0$. Namely, this 0 in which alone there can be grasped what is involved in enjoyment as compared to what is created from the appearance of a loss.

Let it be enough for me to add here this trait or more exactly to this highlighting of the distance between what is involved in the Hegelian solution of *Selbstbewusstsein* from the one that a rigorous examination of the function of the sign gives us every time that there reappears in any way whatsoever that it is in a relationship of 1 to 1 that the solution can be found. I am writing it here in a humorous fashion, make no mistake. Ask yourselves what is involved. What tends to give this image as representing an ideal that one day could be closed by an absolute knowledge? Is it indeed like the H that I have just translated humorously, is it indeed man, *homo*? Or why not the hysteric, because let us not forget that it is at the level of neurotic identification – re-read the text and preferably in German, in order not to be obliged to have recourse to these painful publications that the attention of some zealous people ensures are

the only thing that we have recourse to when we only want to use French. Crappy editions, there is not even a table of contents. Anyway you will see – if you refer to the appropriate article, *Group psychology and the analysis of the ego*, in the chapter on identification, that it is, of the three types of identification stated by Freud, in the middle one that he inserts properly speaking into the field of neurosis, that there appears, that there arises the question of the *einzigster Zug*, this unary trait that I extracted from it. If I recall it here, it is in order to indicate that in the continuation of my discourse I will have to come back to it. Because very curiously, it is in neurosis from which effectively we started, that there appears the most ungraspable form, contrary to what you may imagine - and it is in order to allow you to ward it off that I am announcing it here - the most ungraspable form of the o-object.

(112) Let us come back now to Pascal's wager and to what can be inscribed about it. The fastidiousness of philosophers seems in effect to make us lose the greater part of its meaning. It is nevertheless not because every effort has not been made for that including inscribing the data within a matrix in accordance with the forms in which there are today inscribed the results that are described as those of games' theory. In this form it is put, as I might say, in question. You are going to see how, - strangely, people claim to refute it.

Here in effect is what is involved. Let us clearly observe that the wager is consistent from the following position, we cannot know either whether God is or what He is. The division then of the cases that result from a wager engaged on what? On a discourse that is attached to it, namely, a promise imputed to it, that of an infinity of infinitely happy lives thanks to the fact that I speak and I do not write. Here, even though I speak in French, you cannot know any more, I point out to you, than on the little bit of paper by Pascal which is in shorthand whether this infinity of lives is in the singular or in the plural. Nevertheless, it is clear, in everything that follows in Pascal's discourse that we ought to take it in the sense of a plural multiplication, since moreover he begins to argue that it would be

worthwhile to bet simply in order to have a second life, indeed a third and so on. What is at stake then is indeed a numerical infinity.

Here then is what is engaged, something, as has been said that we have at our disposition for the game, namely, a bet. Let us picture this bet. It is legitimate from the moment that we ourselves have been able to advance in order to grasp what indeed is at stake in the question, namely, this enigmatic surplus that makes us all be in the field of any discourse whatsoever, namely, the o . It is the stake; what we are going to have to justify is why we write it here in this little box. It is the stake and on the other hand, the infinity of infinitely happy lives. What are we dealing with? Ought we to imagine it as this support for the burgeoning of whole numbers, for the burgeoning that is always moreover behind the o -objects by a term. It is a question that is worthwhile evoking here if, as you see, it did not already involve some difficulties. But undoubtedly what was involved was the increasing series.

zero	∞
o	zero

The infinity at stake is the one that Pascal illustrates by representing it by a sign analogous to the one here, the infinity of whole numbers, since it is only in relation to it that the starting element becomes ineffective, I mean neutral. It is under this heading that it becomes zero because it is (113) identified to the addition of zero to infinity, the result of the addition only being able to be represented by the sign that designates one of the two terms. Here then is how things are imaged and if I made this matrix it is not because it appears adequate to me but because it is the ordinary one that people use. Namely, that people remark that according to whether there exists or not what we image here in a legitimate fashion by o , since it is the field of a discourse depending on whether this o is to be admitted or to be rejected. You are going to see there being represented in each of these boxes which here have no more importance than the matrices by which a combinatorial is pinpointed in games' theory.

Subject

zero	∞
o	zero

If this o is to be immediately retained, we have zero as the equivalent of this o , which represents nothing other than a risky stake that in games'

theory must be considered as lost. If we want to articulate in a wager what is involved in Pascal's wager it is not at all a sacrifice. It is the very law of the game that there must be a zero possible, if the promise - just as there is not acceptable anything that is situated beyond death - is no longer tenable, and we ourselves, we have here a zero, but this means nothing, except that here also the bet on the other side is lost.

In fact, in Pascal's wager the stake is identical to the promise. It is because this promise is stated that we can construct this matrix and once it is constructed it is absolutely clear that the asymmetry of the stakes requires that effectively, if the conduct of the subject is only defined by what is determined from a signifying pinpointing, there is no question. The difficulty only begins when we see that the subject is not at all something that we can frame, any more than, earlier, from the relationship of 1 to 1, from the conjunction of any number of signifiers, but from the falling effect that results from this conjunction. And that gives to our *o* here written in the lower left hand box a liaison that is in no way separable from the construction of the matrix itself. It is very precisely what is at stake in the progress that is generated from psychoanalysis. It is this liaison that must be studied in its consequences that precisely creates the divided subject, namely, not linked to the simple establishment of this matrix. Because henceforth it appears obviously quite clear that the zeros in the matrix are themselves only a fiction because of the fact that you can lay out a matrix, in other words, write it. Because the zero written at the bottom is the starting zero, well marked by Peano's axiomatisation as (114) necessary for infinity to be produced from the series of natural numbers. Without infinity, there is no zero to be taken into account because the zero was there essentially to produce it.

It is also indeed from such a fiction as I reminded you earlier, that the *o* is reduced to zero when Pascal makes his argument. Besides, all you are doing is losing zero given that the pleasures of life, this is how he expresses himself, do not amount to much and especially with respect to the infinity that is opened out to you. This is very precisely to use a

mathematical liaison, the one that states in effect that no unit, whatever it may be, added to infinity will do anything more than leave intact the sign of infinity. Except that, nevertheless, as I showed you on several occasions that we can absolutely not say that we do not know whether infinity, as Pascal argues to make it opaque in a way homologous to the Divine Being, that we cannot rigorously say, that it is ruled out that you can say that the addition of a unit will not ensure that we cannot say whether it is odd or even. Since, as you have seen in the decreasing series, all the even operations will be piled up on one another and all the odd operations on the other, to totalise the infinite sum which nevertheless remains reducible to a 1 of a certain type, the 1 that enters into connection with the 0.

You sense here that I am only indicating in passing all sorts of points illuminated by the progress of mathematical theory that in a way, make the veil move. What is under this veil is very precisely what is really involved in the articulation of this discourse whatever it may be, including that of the aforesaid promise. The fact is that in neglecting what it hides, namely, its falling effect at the level of enjoyment you fail to recognise the true nature of the 0-object. Now, what our practice, which is a practice of discourse and nothing else, shows us, is that it is necessary to divide up differently what is involved in the stake if we want to give it its true sense. Pascal himself indicates to us, this is what confuses it in minds, it must be (115) said, that seem to be singularly little prepared by a professorial function to master what is at stake, when what is at stake is a discourse, you are engaged, he tells us, what is less engaging than such a matrix?

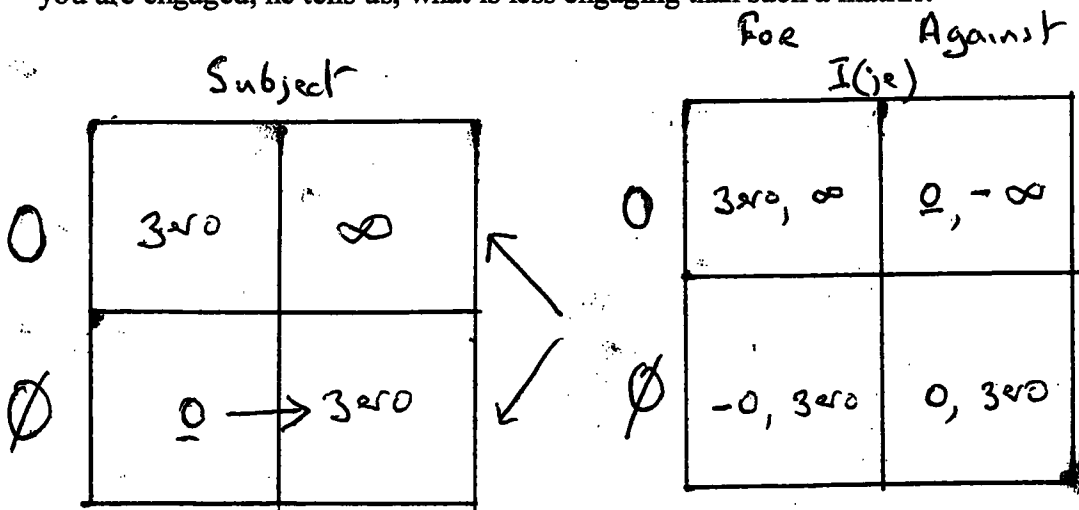

You are engaged, what does that mean if not to play on words, it is the moment of the entry of the "I" into the question. What is engaged is the "I". If there is a possibility in the game of engaging anything whatsoever to be lost, it is because the loss is already there, this indeed is why you cannot cancel the game. Now what we learn from psychoanalysis, is that there are effects that are masked by the pure and simple reduction of the "I" to what is stated. And how can we, for even an instant, when it is a matter of a game imaged by Pascal's pen, neglect the function of grace, namely, that of the desire of the Other. You must not believe that it may also have come into Pascal's mind that even to understand his so ridiculously imaged wager grace was necessary. As I told you, in every naive imaging of the relationship of the subject to demand, there is in short a latent "Thy will be done". This indeed is what is put in question when this will, which is precisely not ours, is lacking. In other words, let us not delay any longer and let us pass on to this God who is indeed the one, the only possible one in question, from Pascal's pen. The fact of giving him the same letters will change nothing about the difference, we are already going to see it being sufficiently articulated in the distribution on the table by which we are indeed going to see that this distribution is no different from itself.

Let us say things crudely: God exists. For the subject supposed to know it, we will then write the couple zero ∞ , in one of the squares of the matrix. I am supposed to know it but something has to be added, that I am for it. And if I am against it, all the while supposing the knowledge that God exists, in that case the choice is between the 0, and this indeed is what is involved throughout the whole thread of the thinking that Pascal states, I deliberately lose the infinity of infinitely happy lives.

And then, I am supposed to know that God does not exist, well then, why not think that I can all the same engage the 0, lose it, quite simply. It is all the more possible because it is its nature to be a loss. Because to measure what is involved in a game where here I keep it at a certain price, the price of less than the infinite, it can be legitimate to ask if it is worth the trouble,

to give oneself so much difficulty to keep it. If there are some people who keep it at the cost of the loss minus infinity you must picture to yourselves that there were many people who threw out the 0 without having any concern about the immortality of the soul. These in general are what are called wise men, the granddads, not simply fathers, granddads. This has a lot to do with the father as you are going to see.

Here, you have those on the contrary who keep the 0 and let nothing (116) disturb their sleep. As regards the next zero, what is striking in this distribution, is the consistency that comes from the subject supposed to know but is it not a consistency made up however little of indifference.

He is, I am wagering for, but I do not know very well what He is. He is not, naturally I wager against, but it is not a wager, all of this has nothing to do with a wager. On the diagonal, you have people who are so certain that there is no wager at all, they go with the wind of what they know, but what does to know mean in these conditions? It means so little that even those who know nothing can form a unique box of it. Namely, that whatever it may be – and you will allow me to remark in passing that I am not extrapolating at all on what is in this respect Freud's tradition, namely, that I am not going beyond my borders – if you consult the volume that I recalled earlier, you will see that all the time Freud makes this calm remark that when all is said and done, everything involved in the belief of a Christian does not lead him to change his behaviour all that much as compared to those who are not so. It is in the position, as I might say, of a purified subject that what happens on the left-hand diagonal can be organised in the little matrix on top. But what is important, what undoubtedly shows us something unexpected is the one who wagers against, on the foundation of what he knows to be and the one who wagers for, just as if what he knows very well not to be, was.

You must think that here this becomes very interesting, namely, that this minus infinity that you see appearing in the top right hand box, this is expressed in the little writings of Pascal by the name of hell. Only this

<u>0</u>	= -∞
0	3 rd AD?

presupposes that there should be examined why the function of the o culminated in this most questionable idea that there is a beyond of death. No doubt because of its indefinite, mathematical slippage, in any kind of signifying chain wherever you pursue the final circumscribing, it always subsists intact as I already articulated at the beginning of the year in a certain schema of the relationships of S and O. But then this may induce us to ask ourselves what is meant by the emergence under the form of minus infinity of something on this table. Is this minus not to be expressed in a way more homologous to its arithmetical function, namely, that when it appears, the series of whole numbers is duplicated which means is divided. There is here the sign of this something that appeared to me the only thing worth recalling at the end of my last discourse. It is that by taking as an o -object and not otherwise what is brought into play (117) in the renunciation proposed by Pascal there is just as much infinity where there is a limit as where it does not encounter this operation of o . In any case, it is a half infinity that we engage with which singularly balances out the chances in the first matrix.

Only it may well be that we should remember differently what is represented in this myth which, even though it forms part of dogma does nothing, as Pascal reminds us, but bear witness that the mercy of God is greater than his justice since he plucks out some chosen ones, while they ought all to be in hell. This proposition may appear scandalous. I am astonished at it since it is quite clear and manifest that we have never been able to imagine this hell beyond what happens to us every day. I mean that we are already in it, that this necessity that surrounds us of not being able, except at a horizon whose limits need to be questioned, to realise the solid o , except by an indefinite repeated measure of what is involved in the cut of o . Is this not enough, just by itself, to make the most courageous lose heart? Only there you are. There is no choice. Our desire is the desire of the Other, and depending on whether grace has been lacking to us or not, what is played out at the level of the Other, namely, of everything that has preceded us in this discourse that has determined

our very conception, we are determined or not to the course of stopping up the o-object.

So then there remains the fourth box, the lower one. It is not for nothing that I allowed myself today to smile about them. They are just as numerous, just as divided up as those who are in the field of the top right. I call them, provisionally, the granddads. You would be wrong nevertheless to minimise the with which they get around, but all the same what I would like to point to you is that, in any case, it is here that we in analysis, have placed the proper norm. *Surplus enjoying* is explicitly modulated as foreign to the question. If the question at stake in what analysis promises us as a return to the norm, how can we not see that this norm is well and truly articulated there as the law, the law on which the Oedipus complex is grounded. And it is quite clear that whatever end one takes this myth from that enjoyment is absolutely distinguished from the law. To enjoy the mother is forbidden, we are told, and this does not go far enough. What has consequences is the fact that to enjoy the mother is forbidden. Nothing is organised except from this first statement. This can be clearly seen in the fable in which the subject, Oedipus, never thought – God knows because of what distraction, I mean because of everything that was developed around him in terms of charm and probably also of harassment by Jocasta – the idea never came to him, even when proofs were flooding in. What is forbidden is to enjoy the mother and this is confirmed in the formulation in another form. It is indispensable to bring all of them together in order to grasp what Freud is articulating, that of *Totem and Taboo*. The murder of the father blinds all these imbecilic young bulls that I see circling around me from time to time in ridiculous arenas. The murder of the father means precisely that you cannot kill him. He has been dead for all time. It is indeed for this reason that something sensible is attached, even in places where it is paradoxical to see there being belled: God is dead. It is because obviously, by not thinking about it, you run the risk of missing one aspect of things.

At the start the father is dead. Only there you are. There remains the Name of the Father and everything turns around that. If that was the way I began the last time it is also with that that I am ending. The virtue of the Name of the Father, is not something I am inventing, I mean that it is not something I made up; it is written in Freud. The difference, he says somewhere, between the field of man and that let us say of animality, consists, wherever it may be, even when this only happens in a masked form, namely, when it is said that there are some people who have no idea of what is the role of the male in generation, why not? What it demonstrates, I mean the importance of this function of the Name of the Father, is that even the very people who have no idea of it invent spirits to fill it. In a word, what is characteristic is that Freud in a very precise place articulates it – I am not going to waste my time telling you on what page and what edition because now there are places where Freudian readings are done and there are all the same competent people to indicate it to those that are interested in it – the essence, in a word, and the function of the father as Name, as pivot of discourse, depends precisely on the fact that after all, you can never know who the father is. You can always look, it is a question of faith. With the progress of science, you manage to get to know in certain cases who he is not, but in any case he remains all the same an unknown. It is altogether certain that this introduction moreover of biological research into paternity cannot be without an impact on the function of the Name of the Father.

Therefore, it is here, at the point where it is precisely only by maintaining oneself in the symbolic, that there is the pivot around which turns a whole field of subjectivity. We have to take the other aspect of what is involved in the relationship to enjoyment and, in a word, to be able to advance, which is our object this year, a little further into what is involved in the transmission of the Name of the Father. Namely, what is involved in the transmission of castration. I will end today, as usual, at the point that one gets to one way or another and I will see you the next time.

Seminar 10: Wednesday 5 February 1969

I am going to restart from where I left you the last time. I said a lot of things the last time, and in particular I succeeded in touching some people by the mathematical evidence that I believe I succeeded in giving of the genesis of what is involved in o , through the simple virtue of the One *qua* mark. This depends on this *factum*, this fabrication that results from the simplest use of this One in so far as it multiplies once it is repeated, since it is only posited in order to attempt the repetition of, to rediscover enjoyment in so far as it has already fled. The first One, by rediscovering what was not marked at the origin, already alters it, since at the origin it was not marked. It is already posited then by grounding a difference that it does not constitute as such but in so far as it produces it. This is this original point that makes of repetition the key of a process about which the question is posed, once it has been opened up, of whether or not it can find its term.

You see that we are immediately brought to the question that is only terminal when applied to a single career, that of Freud, in so far as subject on the one hand, he was also a man of action, let us say a man who inaugurated a path. How did he inaugurate it? This is something that is worthwhile recalling perhaps at a detour in what I will say to you today. But every man's career is committed to something that has death as its limit, and it is only from this point of view that we can find the term of the path traced by Freud in the question that he poses, of the end of analysis, terminable or interminable. This only marks the phase of the question that I am opening up in

saying: is what is engaged for the subject by the fact of repetition as origin, itself a process that has its limit or not? This is what I left open, in abeyance, but nevertheless advanced, by showing on the board the last time in the clearest possible fashion what I was able to express as the division, the bi-partition of two infinities, marking that this is what is fundamentally in question in Pascal's wager. The infinity on which it is based is the infinity of number. Now, by taking this infinity, as I might say, by further accelerating by setting up the Fibonacci series, which it is easy to show is exponential, that the numbers that it generates grow not arithmetically but geometrically. This is the very thing that generates, and precisely in the measure that we are more distant from its origin, the proportion articulated in ϕ . In the measure that these numbers grow, ϕ intervenes there under its inverted form in a more circumscribed and constant fashion. This is all the more striking in that it ties the 1 to ϕ , that it is $1/\phi$, that this proportion of one number to another ends up in the more and more rigorous constant of this $1/\phi$, in the measure that the numbers increase.

I also wrote, taking it at its origin, the series that results from taking things in the other sense. There, because of the fact that ϕ is less than 1, you see the process ends up not simply in a proportion but in a limit. Whatever you add of what is produced, inversely, by proceeding through subtraction, in such a way that it is always true that, in this chain, by taking things in an ascending way, each term is the sum of the two preceding ones, you will find again the function of ϕ in so far as this time it reaches a limit. That in whatever numbers you add these terms, you will not go beyond $1 + \phi$, which seems to indicate that by taking things in this direction, what repetition generates has a term.

This is where there intervenes the well known table in which those, in short, who miss what is involved in Pascal's wager, write what is involved in terms of games theory. Namely, in a matrix that is constructed from distinct boxes, formulate what is involved, if God exists, and write as zero what results from the observation of these commandments, confused here with the renunciation of something. Whether we call it pleasure or something else, it nevertheless remains that here, in appreciating it by a

spontaneity whose astonishing aspect we will see, that they write what is left in this life for believers as zero. As a result of which a future life is marked by the term infinity, an infinity of lives promised to be infinitely happy. In other words, by supposing that God does not exist, the subject, which we write as o , is presumed to be still caught up in the game, make no mistake, literally to know the limited and moreover problematic happiness that is offered him in this life. It is not groundless to choose this if, since God does not exist, it seems clear that there is nothing to expect from the other life.

zero	∞
o	zero

What I am pointing out here is the fragile character of this sort of writing, inasmuch as by following games' theory, the conjunctures can only be determined from the intersection of the play of two adversaries. Namely, that the subject ought to be in this position, while the enigmatic Other, the one involved in short as to whether he holds the wager or not, ought to find himself in that place, God exists or does not exist.

o	zero	∞
\emptyset	o	zero

But God is not involved. In any case, nothing allows us to affirm it. It is from this fact that it paradoxically results that face to face with him, on the table, as I might say, there is not man but the subject defined by this wager. The stake is confused with the existence of the partner, and that is why the signs written on this table have to be reinterpreted. The choice is made at the level of God exists or God does not exist. The formulation of the wager starts from that. And starting from there, only from there, it is clear that if there is no reason to hesitate, namely, that what you may win by wagering that God exists is not comparable to what you can certainly win, even though this certainty can easily be questioned. Because what will you win? o is precisely not defined.

o	zero	∞	
\emptyset	o	zero	

It is here that I open the question - not at the level of a formula that has nevertheless the interest of taking at its source the question of the intervention of the signifier, of what is involved in any act of choice whatsoever. This is where I pointed out the inadequacy of a table that is incomplete because it does not highlight that in taking things at the second stage, the one, perhaps, that restores the correct position of what the matrix involves as it is used in games' theory, is where there should be placed what I distinguish from the subject, the subject that is purely identical to the inscription of the stakes as well as the one that can envisage the case where even if God exists, he wagers against, namely, chooses 0 to his cost. Namely, knowing what this choice involves, that he positively loses the infinite, the infinity of happy lives that is offered him, so that there is reproduced in the two boxes that are marked here what first of all occupied the first matrix, there still remains this fourth to be filled. Namely, that it can be supposed that, even if God does not exist, the 0 as holding the (122) place that you see it occupying in the first box can be abandoned, this time in an explicit way. And because of this fact it appears in the negative, the subtraction of 0 with what we are writing here without any further commentary. And you see that even though it appears to be self-evident as zero, in effect it still constitutes a problem

$$\begin{array}{c}
 \text{I (Je)} \\
 \begin{array}{|c|c|}
 \hline
 \text{zero, } \infty & \text{0, } -\infty \\
 \hline
 -\text{0, zero} & \text{0, zero} \\
 \hline
 \end{array}
 \end{array}$$

In effect, let us now extract in order to isolate it simply in a new matrix something added on by our second composition, namely, 0, $-\infty$, - 0, zero. To be honest, I explicitly mark what I have just indicated in passing in this very discourse, that this zero takes on the value of a question.

$$\begin{array}{|c|c|}
 \hline
 \text{0} & -\infty \\
 \hline
 -\text{0} & \text{zero?} \\
 \hline
 \end{array}$$

In effect, if the zeros were able to be thus posited in the first matrix, this is something that deserves to hold our attention, because what did I say earlier if not that in truth

the only thing that counts in this position of the gambler, of the subject who alone exists, the only thing to be taken into account is the infinite and the finite 0. What do these zeros designate if not that by putting some stake on the table, as Pascal underlined in introducing the theory of gaming, nothing correct can be stated about a game unless you start from this, unless by having a beginning and an end fixed in the rule. What is put on the table, what is called the bet, is lost from the start. The game only exists starting from the fact that it is on the table, as one might say, in a common mass. What the game is is implied and therefore from its constitution the game can here only produce zero. This zero only indicates that you are playing; without this zero, there is no game. Assuredly you could say the same thing about the other zero, namely, this one, that it represents the loss to which the other player resigns himself by bringing this infinity into play. But since precisely what is at stake is the existence of the other player, it is here, in the first matrix, that the zero *qua* sign of the loss becomes problematic.

(123) After all, since nothing forces us to precipitate any movement, because it is precisely in these precipitations that errors are produced, we can indeed abstain from justifying this zero in a way that is symmetrical to what is involved in the other. Because we have something that appears sufficiently in the discussion that the philosophers have had about Pascal's montage. Namely, that it appears in effect that the zero represents not the constitutive loss of the bet but, at least in the dialogue between Pascal and Méré which is not unimportant for the way Pascal writes and at the same time leads us astray – it is never, of course, without our collaboration – about the interest of the montage itself. Namely, that what dominates, is in effect that this zero can be the inscription of one of the choices that are offered which is not to sit down at this table. This is what is done by the person who, in this not simply ideal but effective dialogue, the one to whom there is addressed this schema of the wager. The zero does not mean the constitutive loss of the bet, but inscribes on the table the “no bet”, namely, the one who does not sit down at the gaming table.

zero	∞
0	→ zero

It is starting from there that we have to question what is produced in the second matrix to see how, in it, there can be divided up what is involved in the game. In effect, I already indicated the last time the representations that can be given in the text of our practice. In truth, I was able to indicate it as rapidly as I did because already a certain graph of it had been constructed with what I recalled earlier at the beginning of my articulation. Namely, not the hypothesis, but what can be inscribed and hence the tangible. This means that o itself may well be only the effect of the entry of the life of man into the game. Pascal warns us about it in these terms no doubt not explicitly formulated, I mean in the very one that I am going to state: "You are engaged", he tells us, and it is true. It does not seem necessary to him, because he grounds himself on the word, on the word that for him of course is that of the Church. It is curious that he does not distinguish from it what – this is the blind point of centuries that were not for all that obscurantist – nevertheless provides him with a lot. It is assuredly because of the uneliminatable character of Holy Scripture throughout centuries of thought, that the most radical writing that, for us, appears in it in filigree is not really distinguished. But if I go looking for the weave of this writing in mathematical logic, this leaves my position homologous to his, except that, for us, we can no longer avoid (124) posing the question whether the stake itself is not as such essentially dependent on this function of writing. Let us observe yet another difference, the one that I put as an exergue in the first phase of my statements this year and which can be expressed, since it is not the exact formula, as simply: what I prefer, is a discourse without words, which means nothing other than this discourse that writing supports.

Here a little time to measure the import, the line, the absolutely solidary character of what I am stating at this point this year, with everything that I began to announce under the triad of the Symbolic, the Imaginary and the Real. Note carefully, and this is something that should be insisted on, the difference between philosophical discourse, whatever it may be, and what we are introduced to by this nothing other that is distinguished by starting from repetition.

Philosophical discourse, whatever it may be, always ends up by detaching itself from what it nevertheless brandishes as a system in the material of language. The whole philosophical tradition comes up against the refutation by Kant of the ontological argument; in the name of what? Of the fact that the forms of pure reason, the transcendental analytic, fall under the influence of an imaginary suspicion, and this moreover is what constitutes the single objection, it is philosophical, to Pascal's wager. *"This God whose existence you may conceive to be necessary, says Kant, it nevertheless remains that you only conceive of him in the framework of a thinking that is only based on the prior suspense from which there comes the aesthetic"* qualified on this occasion as transcendental. This means nothing other than: you cannot state anything, state anything in words, except in the time and in the space whose existence, by philosophical convention, we put in suspense in so far as it is supposed to be radical.

Only there is a problem, and this is what gives Pascal's wager its interest. That is why I will permit myself, whatever people may think about having recourse to outworn ideas, to find in it an exemplary turning point. The fact is that in no case is the God of Pascal to be put in question on the imaginary plane because it is not the God of philosophers; it is not even the God of any knowledge. We do not know, writes Pascal, either what he is, of course, or even if he is. This indeed is why there is no way of leaving Him in abeyance by means of any philosophy, because it is not philosophy that grounds him.

Now what is at stake and what my discourse in particular means, when I take up again that of Freud, is very precisely that in grounding myself on what this discourse has opened up, it is essentially distinguished from philosophical discourse, in the fact that it is not detached from what we are caught up and engaged in, as Pascal says. But that, rather than making use of a discourse, when all is said and done, to fix its law to the world, its norms to history or inversely, it puts itself at this place where first of all (125) the thinking subject perceives that he can only recognise himself as an effect of language. In other words that before being thinking, to go quickly, to pinpoint in the

shortest possible way what I am in the process of saying, once you set up the gaming table, and God knows if it has already been set up, he is first of all o. And it is afterwards that the question is posed of harmonising with it the fact that he thinks. But he did not need to think to be fixed as o. It is already done, contrary to what can be imagined, precisely because of the lamentable shirking, of the more and more striking futility of all philosophy, namely, that you can upset the gaming table. I can upset this one, of course, and blow up the tables at Vincennes and elsewhere, but that does not prevent the real table, the gaming table from being still there. It is not the university table that is at stake! The table around which the boss is reunited, whether with the pupils in a pretty little interior, when this interior is his own, nice and warm and grandfatherly, or the one in which it is framed in model nurseries!

This precisely is where the question is. That is why I allowed myself, in a scribbling that I do not know whether you will see appearing or not – it is not at all a scribbling, I spent a lot of time on it the day before yesterday – anyway I do not know whether you will see it appearing, because it will appear in only one place or it will not appear at all, and I am interested in whether it will appear or not appear! In short I went as far as this delusional exorbitance – because for some time I have been deluding in my own heart, these things always come out one day, in one form or another – I would like it to be noticed, this is my delusion or not, that it is no longer possible to play the role that is necessary for the transmission of knowledge if it does not involve the transmission of value, even though now this is inscribed in the registers of credits (*unité de valeur*), but to grasp what can be called a formation effect. This is why, in any case, whoever in the future, precisely because something has happened to this value of knowledge, wants to occupy a place that contributes in any way to this place of formation, even if it is mathematics, biochemistry or anything else whatsoever, would do well to be a psychoanalyst, if this is how there must be defined someone for whom there exists this question of the dependence of the subject with respect to the discourse that holds him, and not that he holds.

So then it is worth saying, since you see that I have just avoided something because of the fact that you are all products of the school, namely, of philosophical teaching. I know that I cannot tackle in too abrupt a fashion what is involved in terms of the change that is written in the second matrix, namely, pose the question of what is meant by the fact that here it is not o or zero because it has never been o or zero as I have just indicated it to you and as Pascal says. But since it is only ever philosophers that have read him, everyone has remained deaf. He said o is zero, which means that (126) o is the bet. It was nevertheless clearly specified in games' theory. No, that changed nothing, they remained deaf! And zero is zero with respect to infinity. Rubbish! What is changed by the fact that there is now not, as has been vainly said, in an imaginary fashion o or zero, but o or $-o$. And if $-o$ effectively means what it seems to say, namely, that it is inverted, what can this thing be? And then also that in one case, whatever happens, even if it is at the cost of something that to be inscribed, appears to need to be costly, what again is this correlation, this equivalence that perhaps allows us to put elsewhere, to perceive that our connecting signs are upset. In any case here are two links that appear to me to be worth questioning. You see that they are not classified quite like the earlier ones.

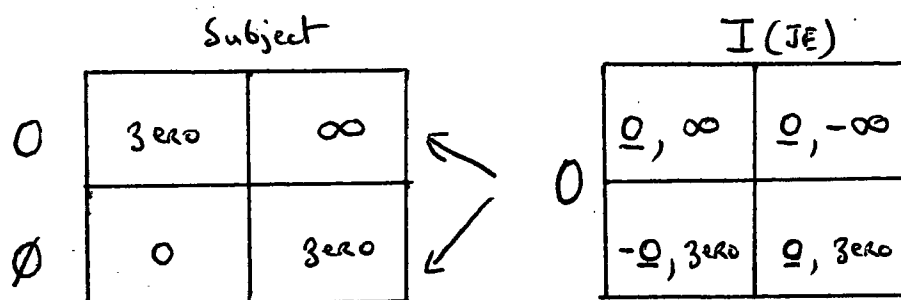

Here, I regret not being further on than what I already, but too quickly, articulated in the last minutes of the last time. Namely, that I recalled that to start from the figure that is indicated here in Pascal's scribbling, the first link, this horizontal line from small o to $-\infty$, we say, is hell. I shouted it out to people who were already making for the exit. But, on the whole, I pointed out to you that hell is something we know. It is everyday life. A curious thing, people know it, people say it, people say nothing but that. But it is limited to discourse and to some symptoms of course. Thank God,

if there were no symptoms, it would not be noticed! If neurotic symptoms did not exist, there would not have been Freud! If the hysterics had not already opened up the question, there is no chance that even the truth would have show the tip of its ear!

So then here, we must make a short halt. Someone that I thank – because you should always thank people through whom presents arrive – reminded me for external reasons about the existence of the chapter of Bergler called “The underestimated superego”, it is in the famous *Basic neurosis* that explains everything. You are not going to tell me that I explain everything. I explain nothing, precisely. This is even what interests you! I try at different levels, not simply here, to ensure that there are (127) psychoanalysts who are not imbeciles. My operation is an advertising operation, not to draw people into the hole of a school, but to try to give the equivalent of what psychoanalysts ought to have to people who have no means of getting it. It is a despairing enterprise. But experience proved that the other also, that of teaching it to psychoanalysts themselves, seems destined to fail, as I already wrote. Imbeciles, I mean as subjects, because as regards getting on in their practice, they are pretty smart! And it is precisely a consequence of what I am in the process of stating here. It is in conformity with the theory. This is what proves not alone that there is no need to be a philosopher but that it is much better not to be one. Only that has a consequence, which is that one understands nothing. Hence what I also spend my time stating, that it is much better not to understand. Only the problem is that they understand all kinds of little things, so it is swarming. For example “The underestimated superego” is a brilliant chapter, first of all because it collects together all the ways in which the superego has been articulated in Freud. Since he is not a philosopher, he absolutely does not see that they all hang together. Moreover he is charming, and he admits it. That is what is good about psychoanalysts, they admit everything! He admits that he has written to a gentleman, it is in a note, Mr H H Heart, who was making extracts from Freud. So then he wrote to him: “Send me some quotations about the superego”. After all that can be done; it is moreover also in conformity with the theory; you can take things like that, with a pair of scissors, if writing is so important, everywhere there is superego, snip, snip, you cut it out! You

make a list of fifteen quotations. And I must say that here I am being humorous. But he is reaching out to help me. Because of course Bergler has read Freud, anyway I like to imagine it! But all the same he admits that in order to write this chapter, he wrote to H H Heart to give him quotations about the superego. The result is that he can obviously clearly mark, exactly at the same level that all the existing psychoanalytic reviews are at, except mine, of course, the degree to which it is incoherent. It begins with the censor at the level of dreams; people believe that the censor is an innocent, as if it were nothing precisely to have the pair of scissors with which one subsequently constructs the theory. And after all, this becomes something that titillates you. And then afterwards it becomes a big bad wolf. And then after that, there is nothing more. And after that, Eros is evoked, Thanatos and the whole caboodle! Thanatos is going to have to find its place there. And then, I make arrangements with this superego; I bow and scrape to it. Ah! Dear little superego!

Good. Thanks to this presentation, of course, you get something it must be said that is rather laughable. You really have to be in our epoch for no one to laugh. No one laughs. Even a professor of philosophy. It must be said that they have got to a point, (128) in our generation! Even a professor of philosophy can read this stuff without laughing. They have been checkmated! There was all the same a time when there were people who were not especially intelligent, a chap called Charles Blondel, who shouted and roared about Freud. At least it was something. Nowadays even the people least in a position to imagine what is involved in a psychoanalysis read these absolutely astounding things without complaint. No. Everything is possible, everything is accepted. We are – moreover things are showing their lineaments elsewhere than in the real before descending into it – really in a regime of intellectual segregation.

Well then, this chap has noticed a whole lot of things. When something is there, under his nose, he understands it. And I would say that this is what is sad because he understands it at the level of his nose, which cannot of course be absolutely like that; it is necessarily pointy. But he sees a tiny little thing. He notices that what is

explained to him, like that, in the quotations from Freud, as being the superego, he notices, that this ought to have a relationship with what he sees all the time. So then he begins by noticing, but like that in an intuitive way, at the level of sensation, that what is called *Durcharbeitung*, *l'élaboration* as it is translated in French – people spend their time noticing that it is untranslatable. *Durcharbeitung*, is not *élaboration*, we can do nothing about it; since there is not in French a word to say “work through”, drilling, it is translated as *élaboration*; everyone knows that in France, people elaborate; it is something like smoke.

Analytic elaboration is not at all like that. People on the couch see that it consists in coming back the whole time to the same thing. At every turn one is brought back to the same thing. And it is necessary for that to last in order to get precisely to what I have explained to you, to the limit, to the end, naturally when one is going in the right direction, when one encounters a limit. He says “That’s an effect of the superego”. Namely, he notices that this kind of big wicked thing that nevertheless is supposedly extracted from the Oedipus complex, or again from the devouring mother, or from anyone of these see-saws. He notices that this has a relationship with this exhausting, boring, necessary, especially repeated aspect by which one arrives at something that, in effect, sometimes, has an end. How does he not see that this has nothing in common with this kind of picture of a scenario where the superego is, as people say, an agency, which would be nothing, but where people make it live like a person. Because, people have not well understood what an agency is, we attach the idea to the superego.

All of this must happen not on the other stage, the one that Freud spoke about, the one that functions in dreams, but in a kind of little play, where what is called analytic (129) teaching makes you play with puppets. The superego is the police superintendent and he hits the Guignol, which is the ego, on the head. Why, by simply seeing this rapprochement that he senses so well from the clinical point of view, with elaboration, *Durcharbeitung*, does this not suggest to him that the superego may well be found in something that would not require, like that, the

multiplication of agencies in the personality. And then at every instant he lets it slip, he admits it, namely, that people have clearly mapped out, he says, that this has a relation with the ego ideal. But it must be admitted that absolutely nothing is known about it; no one has yet put things together.

All the same, in order that these discourses should be something other than memoirs of the psychoanalyst, namely, evoking the case of a young woman who, in this connection, one sees clearly that it was a guilt feeling that made her come into psychoanalysis. Let us hope that it was the same thing that made her get out of it! You can perhaps all the same note that, for example, this kind of little manoeuvre of a measure that is precisely the measure of what cannot be measured because it is the starting bet. This can in effect in some cases be represented with the greatest precision and be written on the board. It is in the manner of a certain way of regularly balancing that one manages to fill up this something that can in certain cases be represented as the One. You can all the same see that there is some interest in articulating in a way that is really precise something that allows it to be conceived that it is not at all in effect an abuse of terms to bring together, even in the name of a minimal intuition like that, the *élaboration*, the *Durcharbeitung* in the treatment, with the superego.

So then you have to choose. You cannot tell us that the superego is the big bad wolf and rack your brain to see whether it is not in the identification that I have with some person that this severe superego is born. That is not how questions should be put. It is like the people who tell you that if so-and-so is religious, it is because his grandfather was. That is not enough for me, because even if you had a religious grandfather you may also perhaps see that it is stupidity, is that not so?

It is necessary all the same to distinguish the direction of identification as compared to other things. It is necessary to know whether identification in analysis is the goal or is the obstacle. But this might well perhaps be the means by which one engages people precisely no doubt to do it, but by the same fact, it is abolished. And it is in the fact

that it is abolished precisely because one has done it that they can appear something else that we can call the hole on this occasion.

I am going to leave you there today. I tried at the end of this discourse, to show you that it is a discourse that is of direct importance to bring some fresh air into our (130) practice. By that I mean that by using what were certainly not experiments in smell, it was not by following his nose that Freud advanced, one can in effect see in it, in the development of a function through his thinking, the framework that allows its consistency to be given. But it is indispensable if one wants to advance with something other than little stories, to assemble this coherence and to give it consistency and solidity. This would perhaps allow there to be seen quite different facts than simply analogical facts.

What I am saying does not take anything away from the importance of detail, precisely as Bergler insists. But read this chapter to see that even something that is relevant, well oriented, but oriented like particles of iron filings when you tap into a field already magnetised, contains no kind of true motivation for the power and the importance of detail. And why in effect it is only the details, it is quite true, that interest us. Again it is necessary to see in every case what is interesting. Because if one does not know it, one brings together disparate details in the name of pure and simple resemblance, while this is not what is important. We will take it up the next time at the level of the third figure.

Seminar 11: Wednesday 12 February 1969

(131) Very bored with everything that is happening, huh! You too I think. One cannot all the same not notice it, because I am in the process of asking myself whether I am here to do my usual thing or whether I am occupying the place! Anyway! Some benevolent ears were prepared to understand that some of the things that I put forward, specifically during my second last seminar, had some relationship with a science – who knows? With perhaps not a new science, but with a bringing up to date of what is involved for the conditions of science.

Today I sense, for all sorts of reasons, even if it is only because we are getting close to Mardi-Gras, so then it is appropriate, that I should gently change the direction of things. I sense it, like that, after balancing what I thought out this morning before seeing you. I am going to bend myself a little bit towards something that you can call whatever you want, but which is rather a moral note. How could one moreover escape it, in the aura, in the margin, in the limits of that through which I tackled something which is Pascal's wager. It is certain that we cannot fail to recognise this incidence, even though, of course, what inspired me to speak to you about it, is that Pascal's wager is at a certain joint, and this, all the same, I am going to recall,

But, like that, as a way of introducing things a little and of relaxing, however little, the atmosphere – I told you that we were getting close to Mardi-Gras – I am going to read you a letter that I received. I am

not going to tell you who sent it to me, nor even from what town it came.

“Dear Mr Lacan. We are students and we have read almost all of your Ecrits. We find a lot of things in it. Obviously it is not always easy to approach but this all the same deserves our congratulations.....” I don’t get those every day! *“We would really like to know how one sets about writing such difficult things...”* I am not sending anyone up, and certainly not these chaps that I find really... anyway I will tell you what I think about it; there must have been two of them to write that! *“...it would be useful to us in our examinations. We may well have a degree in philosophy, but it is getting more and more complicated to get through the selection. We think that it would be better to use trickery and astonish the teachers rather than persisting in a style of banal down-to-earth discourse”.* And they add *“make no mistake. Could you point us to some little fiddles in this direction?”* That strikes (132) me, because all I am saying is that, fundamentally, that is what I am in the process of doing! *“On the other hand, we would like again to ask you something if it’s not too daring: Do you think you could send us as a souvenir one of your lovely bow ties? We would really like that. Thanking you in advance, we say farewell, Mr Lacan, and please receive our most respectful homage.”* I am not going to leave that lying around because ...they are not really up to date. They do not know that I have been wearing a polo neck for some time!

For me, that gives an echo, confirmation, a resonance to something that moves me when I hear right minded people going on, like that, since the month of May: “Things are no long the way they were”. I think that where we are at, it is more than ever like it was before. And after all, I am very far of course from limiting the phenomenon to this little report that this letter gives of what is a corner of the affair. Obviously there are many other things at stake.

Only what is striking, is that from a certain point of view, this letter in my eyes may very well sum up the way people have listened to me, but in a zone that is not at all as distant from me as this town which is all the same a good distance away. As you see, they are not very up to date! But in any case, it is an aspect of the way that teaching is received. And then I do not see why one would blame them for the bow tie. Because there is someone who played a pivotal role in a certain examining board, like that, that a certain British Society sent us a long time ago, who put that down as a point that was quite worthy of putting in the scales with the rest of my teaching. I mean that that was how it was, this was on one pan and on the other, my bow tie. Namely, with the help of this accessory the identification of those who presented themselves at that time as my pupils was supposed to be possible. So then you see that this is not limited to the level of these little dears, nice naive people. They are perhaps not so naïve as that because, as they told you, you have to be a little tricky. We will come back to it.

So then we will take things up where we had dismantled them a little, namely, in the table of the wager. On the left – the blue lines are made to show where the limits of each one of these schemas stop, so that they do not overlap one another, either really or in your minds – so then the one on the left is the one with which I believed I should complete the matrix in which, in imitation of what is practised in games theory, one could schematise what was effectively discussed throughout the whole of the nineteenth and even during a good part of the beginning of our century around Pascal's wager. Namely, the way of demonstrating how, in a way, Pascal was trying to swindle us.

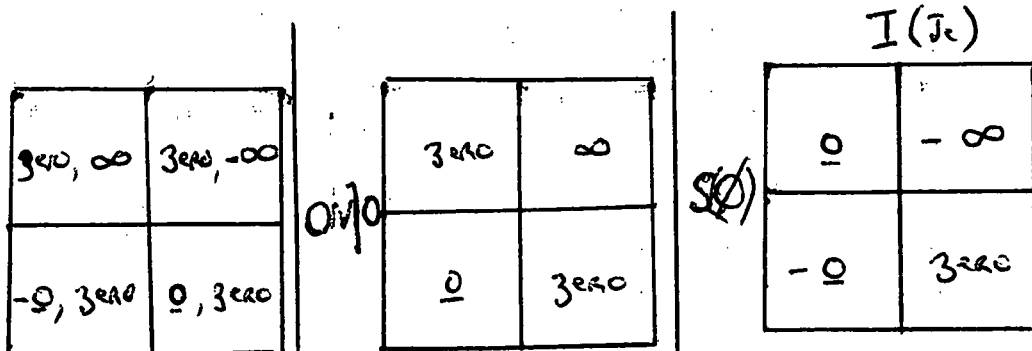

I think that I have sufficiently made you sense that by reason of the (133) function of the zeros that do not really form part of the results of a wager that might be made against a partner, because it is precisely the existence of the partner that is in question and that it is what you have to wager on. In these conditions the two lines of possibility that are offered to the gambler do not intersect with any line of possibility that might belong to the Other, since one cannot even be sure of the existence of the Other. It is then at the same time on the existence or non-existence of the Other, on what promises his existence and what allows his inexistence, it is on this that the choice is brought to bear, and in this case it is plausible – I am saying, it is plausible, of course if one has a mathematical mind – to wager, and to wager in the sense that Pascal proposes.

Only, you will not forget that I introduced at this state of the affair, in order of course not to give rise to misunderstanding and the belief that here I am lending myself to something which would be the indication of the advantage of this solution, I effectively remarked the following. And in the very introduction to the reminder of the wager as it is presented, much less than it is through the grid of the discussions that have become classic, I pointed out that at this level one could substitute for the choice to be made on the subject of the existence of God, the remark that one would fulfil the function – which would completely change its sense – this remark that what is at stake, that what could be at stake, is this radical formulation which is that of the real, in so far as we can conceive of it and as moreover we sometimes put our finger on it, that it is not conceivable to imagine any other limit of knowledge than this stopping point at which one has only to deal with this, something unsayable and which either is or is not. In other words something that is related to heads or tails.

This was of course to put you in tune with what is involved in not losing the plot. Namely, that we are not amusing ourselves. We are in the process of trying to give articulations of such a kind that there can

be played out for us the most important decisions that are to be taken. As it happens our times mark more and more that these most important decisions, in so far as they may be those of the psychoanalyst, may (134) also coincide with those required at a key point in the social body, namely, the administration of knowledge, for example.

But then, even though on this point it is well understood that I cleared the board, that I am not doing history and that I do not see why such a precise system, especially if we correctly conceive the joint at which it is situated, that Pascal's wager would have less resources for us than it had for its author. And we will indeed come back to this question of the situation, all the better because we are going to illuminate it now. It is therefore not, as you are going to see right away, doing history, to remind you, as I recalled the last time to remind you that in Pascal's time, Revelation existed. And I even stressed what was at stake with these two levels, the word of the Church, and then Sacred Scripture, and the function that Sacred Scripture played for Pascal. And it is obviously not to remind you that Newton also, who had other things on his mind, produced a big book – my hobby being bibliophilic, it happens that I have it, it is superb – which is a commentary on the Apocalypse and of Daniel's prophecy. He gave just as much care – I mean in the calculation, in the manipulation of numbers that are nevertheless extremely problematic as those that are at stake when it is a matter of situating the reign of Nebuchadnezzar for example – as in his study on the laws of gravity. This should be remembered then in the margin, but it does nothing for us.

What is at stake at this stage, is to remark that at the level that Pascal then proposes his wager to us, whatever may be the relevance of our remarks about what is involved in it in the final term, namely, that such a proposition can only be conceived of when the knowledge of science is born, it nevertheless remains that, for him, the wager reposes on what we can call the word of the Other, and the word of the Other naturally conceived of as truth.

So then, if I am taking things up again at this point, it is because some people are not unaware, and I am informing the others - it would moreover be easy if they had behaved like my charming correspondents, if they had read almost all my *Ecrits* - that they should know about the connected and disconnected function that I articulated in a dialectic, as distinguishing if not opposing knowledge and truth. It is the last article that I collected; its title is very precisely *Science and Truth*. And as regards what is involved about the truth, everyone also knows, that in another one of these articles called *The Freudian Thing*, I wrote something that could certainly be understood as follows: that its property is that it speaks. We are thus supposed to be, or rather I am, I am supposed to be on a certain axis that, why not, could than be described as obscurantist since it connects up with this. Namely, that I am supposed to be giving a leg up to what Pascal is instilling, in so far (135) as he tries to bring us back to the plane of religion. So then, obviously, the truth certainly speaks, you will tell me. But obviously it is what you would say if you have understood nothing about what I say - which is absolutely not to be ruled out! - because I never said that. I made the truth say: "Me the truth I speak". But I did not make it say: "Me the truth I speak, for example, to express myself as truth", nor "To tell you the truth". The fact that it speaks does not mean that it tells the truth. It is the truth. It speaks. As regards what it says, you are the ones who are going to have to sort yourselves out with that. That could mean, this is what some people do: "Talk away, it's all you are able to do". If I may dare say so, I grant a little bit more to the truth. I have since even attributed to it the fact that it talks (*cause*), in effect, and not simply in the sense to which "talk away" (*cause toujours*)". It even causes, talks at full tilt. I mean that, in the same article, I recalled Lenin's word on the Marxist theory of society, which, he says: "Will triumph because it is true". But not necessarily because it tells the truth. That can be applied there also.

Naturally, I am not going to dwell too long on it. Because it is said that my name is quoted to advantage – I did not go looking for it, I must say, because I did not have the time – in *l'Humanité*, because supposedly I am supposed to have begun this year, like that, seeing the way the wind was blowing, by making a mediation between Freud and Marx. Thank God, since I had the flu last weekend, this gave me all of a sudden a stimulus for what is called work, namely, great agitation. I set about going through the terrifying quantity of paper that I must make sure to destroy before I die, because God knows what would be done with it otherwise! I notice that I spoke about Marx, of use value, of exchange value, of surplus value. I noticed, in a word, that my Italian translator, whom I pinpointed, when I made the leap, to draw this sort of analogy between surplus value and *surplus enjoying*, that my Italian translator, it happened that she was there two years ago, had no merit in telling me that, in short, this was surplus value. Because I already spoke so much about Marx in connection with a certain number of fundamental articulations around what is involved in psychoanalysis that I ask myself whether I contributed anything new except this name *Mehrlust*, *surplus enjoying* as an analogy for *Mehrwert*. All of this to indicate moreover that through these radical points, naturally they absolutely do not develop in the same field, but since we are evoking Lenin, it is not any worse then to recall that what is at stake in Marxist theory, in so far as it concerns the truth, is what it states in effect. The fact that the truth of capitalism is the proletariat. It is true. Only it is from that very thing that there emerges the series and the import of our remarks about what is involved in the function of the truth. It is that the revolutionary consequence of this truth, this truth from which Marxist theory starts, naturally it goes a little bit (136) further since what it constructs the theory of, is precisely capitalism, the revolutionary consequence is that the theory starts in effect from this truth, namely, that the proletariat, is the truth of capitalism.

The proletariat, what does that mean? It means that labour is radicalised to the pure and simple level of merchandise; which of course means that this reduces the worker himself to the same measure. Only once the worker, because of the theory, learns to know of himself as that, one can say that through this step, he finds the paths of a status – call that what you will – of a *savant*. He is no longer a proletarian, as I might say *an sich*, he is no longer pure and simple truth, he is *für sich*; he is what is called class consciousness. And he can even at the same time become the class-consciousness of the party in which people no longer speak the truth.

I am not satirising. I am only recalling that obvious things – that is why it is a relief – do not arise in any way from the scandal that is made of them, when people understand nothing about anything. Or that, if one has a correct theory of what is involved in knowledge and the truth, there is nothing easier to expect, that in particular it is hard to see why people should be astonished that it is from the most Leninistically defined relationship to the truth that there flows this whole Leninising in which the whole system is swamped! If you get it into your heads that there is nothing more soothing (*lénifiant*) than the hard men, you will be recalling, like that, a truth that has already been known for a long time. And then truly has that not always been known from all time? If people had not for some time, and I will tell you why, been so persuaded that Christianity is not the truth, people would have been able to recall all the same that for a certain time and not a short one, it was. And that what it proved is that around every truth that claims to speak as such, there prospers a clergy that is necessarily lying.

So then I ask myself why people are so high and mighty about the functioning of socialist governments! Will I go so far as to say that the pearl of the lie is the secretion of the truth? That would sanitise the atmosphere a little, an atmosphere moreover that only exists because of the fact that a certain type of cretinisation whose name I must give

right away because at the end of what we have to say today, I will have to pin it again into one of these little squares. It is what is called a belief in progress (*progressisme*). I will try, of course, to give you a better definition than this reference to these effects of scandal, I mean producing scandalised souls. These things ought to have been ventilated a long time ago by a reading of Hegel, the law of the heart and the delusions of presumption. But in the way of all things that are a little rigorous, when they come out, of course, no one thinks of remembering them at the appropriate moment. That is why I put as an (137) *exergue* at the beginning of my discourse this year something that means that what I prefer, is a discourse without words.

So then what is at stake, what might here be in question if one wished, as they say, to lick the plate to the point that we can profit from it, putting our finger on it, is to notice that things do not have such bad effects as all that. Since, when I say that the service of the field of truth, the service as such – a service that is not asked of anyone, you have to have the vocation for it – necessarily leads to lies, I want also to point out the following, because one must be fair. This gives rise to enormous work. For my part I adore that, when it is the others, of course, who work! That is why I treat myself to the reading of a good number of ecclesiastical authors and I admire the patience and the erudition they must have had to cart around so many quotations that come at the right point for me or that are of some use to me. It is the same thing for the authors of the communist church. They are also excellent workers. I may well, like that, for some of them, in day to day life, not be able to tolerate them any more than personal contacts with priests. That does not prevent them from being capable of doing very good work and I enjoy myself when I read one of them on *The hidden God*, for example. This does not make the author any easier to associate with.

So then, in short, the fruit of what is involved, after all, all the same, for knowledge is not at all to be neglected. Because people are a little

bit too concerned with the truth and they are so bogged down in it that they end up by lying. The only real question – because I said that here I would go to the limit – is not at all that this should have consequences. Because you see that after all it is a form of selection of elites, that is why they pick up also, in one field as in the other, so many mentally handicapped. There you are, that is the limit! That is the limit. But you must not believe that it is simply to amuse myself, by giving like that a little rap on the nose to groups of whom one does not know, after all, why they should be any more preserved than others from the presence of the mentally handicapped. It is because we analysts can perhaps on this point begin something that is precisely very important.

Here I refer you to the key that was quietly contributed by our dear Maud – Maud Mannoni for those who do not know who she is – the relationship of the mentally handicapped to the configuration that interests us, that for us analysts, is obviously burning precisely at the level of the truth. That is even why we are not able any more than the others to take precautions; even our lies, to which of course we are forced, are less impudent than the other – less impudent but more timid, it must be said. There are some all the same that, in this relationship, preserve some vivacity and precisely the works that I am evoking on the subject of what all of a sudden starts floating into (138) mental handicap with which, I must say that in my own regard, I got rather used to in the first phase of my experience. I was full of admiration at seeing the armfuls of flowers that I collected, flowers of truth when, inadvertently, I took into analysis what Freud, and how wrong he was, seems to have thought one should exclude from it, namely, a mentally handicapped person. There is no psychoanalysis, I must say, that goes better, if one means by that the joy of the psychoanalyst. It is perhaps not altogether uniquely what one might expect from a psychoanalysis, but in any case it is clear that, as regards what it conceals in terms of truths that precisely he brings out as pearls, unique pearls. Because here I only evoked this term in connection

with lies, it must all the same be, that in the mentally handicapped person not everything is as handicapped as all that. And what if the mentally handicapped person were – you will understand better what I mean if you are able to refer to good authors, namely, to Maud Mannoni – a little trickster? This is an idea that came to some people. There is someone called Dostoyevsky who called one of his characters the Idiot, the one who conducted himself most marvellously, no matter what social field he was traversing and whatever embarrassing situation he found himself in.

I sometimes evoke Hegel, it is not a reason not to recast him. “The ruse of reason”, Hegel tells us, I must say that this is something I have always been suspicious of. For my part, I have very frequently seen reason being screwed, but as for succeeding in one of its ruses, I must say that during my lifetime I have not seen it. Perhaps Hegel saw it. He lived in the little courts of Germany where there are many mentally handicapped and in truth, it was perhaps there that he found his sources. But as regards the ruse that may be in simple spirits, and it is not for nothing that someone who knew what he was saying baptised them as blessed, I am leaving the question open. And I am ending with this simple reminder very necessary and very healthy to recall in the context that we are living in.

What I would like to do now, is to take up at the level at which I left you the last time, namely, in the matrix that is isolated by the fact that it is no longer a matter of knowing what one is playing, a game where after all, all that Pascal’s wager means, is that you cannot play this game in a correct fashion unless you are indifferent. Namely, that it is in the measure in which there is no doubt that the stake, infinite in so far as it is on the right, on the side of the existence of God, is a much more interesting stake than this kind of thing that I do not know what it is and that is represented as what? After all, in reading Pascal, this comes down to saying all the dishonesties that you will not do by following the commandments of God, and by following the

commandments of the Church, some little supplementary inconveniences specifically in the relationships to the holy water font and some other accessories.

(139) It is a position of indifference, when all is said and done, with regard to what is involved. And this properly speaking all the more easily reaches the level of the wager as Pascal presents it in that after all, this God, he underlines it and it is worthwhile having it from his pen, this God, we do not know what he is nor if he is. It is in this sense that we can take Pascal. And it is here, namely, that there is an absolutely fabulous negation. Because, after all, in the preceding centuries, the ontological argument – I am not going to let myself be drawn into it but, to the eyes of all sensible spirits, and we would do well to follow its grain – had its whole weight. This amounted to nothing except to say what I am also in the process of teaching you, namely, that there is a hole in discourse, there is somewhere a place where we are not able to put the signifier that is necessary for all the rest to hold together. He thought that the signifier God could make things stick. In fact, it works at the level of something, about which after all it is a question of whether it is not a form of mental handicap, namely, philosophy. In general it is accepted, I mean among atheists, that the Supreme Being has a sense. Voltaire, who is generally thought to be pretty smart, held onto it *mordicus*. He had respect for Diderot, who had a clear advance, a good length over him as can be seen in what he wrote. It is also probably for that reason that almost everything that Diderot wrote that was really important only appeared posthumously, and then that as a total it is much less substantial than in the case of Voltaire. Diderot for his part had glimpsed that the question is that of the lack somewhere and very precisely in so far as naming it means putting a stopper into it, nothing more.

It nevertheless remains that in Pascal, we are at the point of the joint, at the point of the leap where someone dares to say what was there from all time. It is like earlier, it is more like before than ever, only there is

a moment when that is separated. It ought to be known that he says “the God of Abraham, of Isaac, and of Jacob”, has nothing to do with “the God of the philosophers”. In other words he is one who speaks, I would ask you to pay attention to it, but he has this originality that his name cannot be pronounced, so that it is in this way that the question is opened up.

That is why, a curious thing, that it is through a son of Israel, someone called Freud, that we find ourselves really seeing for the first time at the centre of the field, not simply of knowledge, but of what makes knowledge grab our guts and even, if you wish, our balls, that here there is properly speaking evoked the Name of the Father and the tralala of myths that he lugs about. Because if I had been able to do my year on the Name of the Father, I would also have told you the result of my statistical researches; it is extraordinary that even in the Fathers of the Church people speak so little about this business of the Father. I am not talking about the Hebrew tradition, where very obviously it is everywhere in filigree and also, of course, if it can be in (140) filigree, it is because it is very veiled. That is the reason why, in the first seminar, the one after which I closed shop that year, I had begun by speaking about the sacrifice of Isaac, noting that the sacrificer is Abraham. These are obviously things that there would be every interest in developing, but that by reason of the change of configuration, of context and even of audience, there is in effect very little chance that I will ever be able to come back to it.

Nevertheless, a tiny little remark because there are words that are very much *à la mode*. From time to time, I pose questions like that; does God believe in God, for example? I am going to ask you one. If at the last moment, God had not held back Abraham’s arm, in other words if Abraham had been in too much of a hurry and had butchered Isaac, would it have been what is called a genocide or not? People are talking a lot at the moment about genocide and the fact of pinpointing the locus of a truth about what is involved in the function of genocide

especially concerning the origin of the Jewish people, I believe that this landmark deserves to be noted. In any case, what is certain, as I underlined in this first lecture, is that to the suspension of this genocide there corresponded the butchering of a certain ram that is quite clearly there as a totemic ancestor.

So then here we are at the second phase, the one that is brought out by taking what is involved when there is no longer indifference, namely, the initial act of what is involved in the game. What is in the game, Pascal settles. I have already lost it, or I am not playing at all. This is what is meant by each of the two zero's that are there in the central figure (page 3); they are only the indices of the bet on the one hand or the "no bet" on the other. Only, all of this only holds up if the bet, as Pascal says, is taken to be worth nothing. And in a certain way it is true. The o-object has no use value. It has no exchange value either as I already said. Only this, what was in question in the bet, once one has noticed the way it functions, and that is the reason that psychoanalysis is what has allowed us to take a step into the structure of desire, it is in so far as the o is what animates everything that is at stake in the relationship of man to the word. Precisely that a gambler, but a different gambler to the one that Pascal speaks about, namely, the very one that, because he sensed something all the same, Hegel understood, even though despite appearances his system is faulty. Namely, that there is no other game except risking everything for everything, that this is even what is called simply to act. He called that the fight to the death for pure prestige. This is precisely what psychoanalysis allows to be rectified. It is a matter of much more than life about which we do not after all know very much. We know so little about it that we do not hold onto it all that much, as can be seen every day provided you are a psychiatrist or simply are 20 years old. It is a matter of what (141) happens when something different, which has not been named and which is not any more so because I have called it o, is at stake. And this has meaning precisely only when it is brought into play with, on the opposite side, what is nothing other than the very idea of

measure, measure in its essence that has nothing to do with God but that is in a way the condition of thinking. Once I think about something, however I name it, it comes back to calling it the universe, namely, One.

Thanks be to God, thinking has had enough of swarming around inside this condition to notice that the One, does not happen just by itself. And what is at stake, is to know the relationship that this has with this "T". This is described by the fact that in the second table there is an o on the one hand, which is no longer the o abandoned to the destiny of the game, the bet, which is the o in so far as it is me who represents myself, that here I am playing against, and precisely against the closure of this universe that will be One if it wishes, but that I am an extra o.

This ineradicable God who has no other foundation when one looks closely at him, than being the faith in this universe of discourse which is certainly not nothing. Because if you imagine that I am in the process of doing philosophy, I am going to have to give you an apologue. It is necessary to put in the corners big figures to make what is meant understood. You know that the modern era began like the others, this is why it deserves to be called modern, because otherwise, as Alphonse Allais says, look how modern we were in the Middle Ages! If the modern era has a sense, it is because of certain breakthroughs one of which was the myth of the desert island; I could just as well have started from it as from Pascal's wager. This still continues to worry us. What kind of book would you take with you onto a desert island? Ah! That would be amusing, a pile of the Pléiade, what fun one would have behind the leftover shrimps, somewhere, in reading something from the Pléiade, it would be really exciting! Nevertheless that has a sense. And to illustrate it I am going to give you my response. A moment of suspense: "What book would he take onto a desert island?" So then, tell me!

X – The Bible.

Lacan: The Bible, naturally!!! I can do without it! What do you think I would do with it on a desert island! Onto a desert island I would take Bloch et Von Warburg. I hope all the same that you all know what it is, it is not the first time that I have spoken about it. Bloch and Von Warburg is entitled - that lends itself to misunderstanding of course - *Dictionnaire étymologique de la langue française*. Etymological does not particularly mean that you are given the sense of words starting from the thinking that preceded their creation. It means that in connection with each word, you are given a little pinpointing with the dates of their forms and of their uses in the course of history. This has (142) such an enlightening, fruitful value, that just by itself, in effect, one can do without anyone. You see the degree to which language, is company all by itself. It is extraordinarily curious that Daniel Defoe, to take the one who did not invent the desert island – the one who invented it, is Balthazar Gracian, who was someone of a different class. He was a Jesuit, and moreover not a liar. It is in *Criticon*, in which the hero, returning from somewhere or other in the Atlantic, spends a certain time on a deserted island, which has for him at least the advantage of protecting him from women. It is extraordinary that Daniel Defoe did not notice that Robinson did not need to wait for Friday. That already the simple fact that he was a speaking being and knew his language perfectly well, namely, the English tongue, was an element absolutely as essential for his survival on the island as his relationship with some tiny natural trifles from which he succeeded in making a hut and feeding himself.

Whatever may be the case for what is at stake in this world which is that of signifiers, I cannot do better today, with the advancing time than to draw again what I gave here in the first terms that I put forward, namely, those to which the moment we have got to in mathematical logic allows us to give some rigour to. And in starting from the definition of the signifier as being what represents a subject

for another signifier, this signifier, I am saying, is other, which simply means that it is signifying.

$$S \rightarrow O.$$

Because what characterises, what grounds the signifier, is absolutely nothing whatsoever that is attached to it as sense as such. It is its difference. Namely, not something that is stuck to it, to itself, and would allow it to be identified but the fact that all the others are different to it. Its difference resides in the others. That is why this constitutes a step forward; but an inaugural step by asking oneself whether from this Other one can make a class, one can make a sack, and one can, in a word, make what is involved in this famous One.

Because then, as I have already drawn it, if the O is 1, it must include this S in so far as it is the representative of the subject, for what? For O. And this O, by being the same as the one that you have just seen here, as you see, is found to be what it is, a predicate in so far as the 1 in question is no longer the unary trait but the unifying 1 that defines the field of the Other. In other words, you see there being indefinitely reproduced the following, with here something that never finds its name, unless you give it in an arbitrary fashion. And that it is precisely in order to say that it does not have a name that names it that I designate it by the most discreet letter, the letter o.

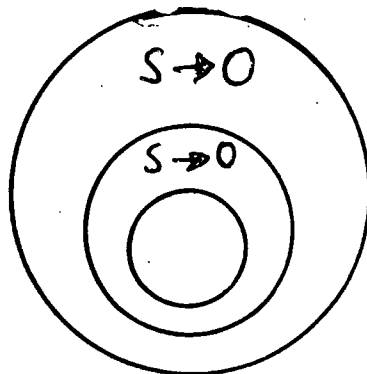

What does that mean? Where and when is there produced this process (143) which is a process of choice? It is very precisely as regards the One, the game that is involved in so far as he really plays, not *jocus*, here a play with words, but *ludus* as it is forgotten from its Latin origin

of which many things are to be said but undoubtedly this comprises this deadly game that I spoke about earlier, and that this varies the ritual games that Rome had inherited from the Etruscans – the word is very probably itself of Etruscan origin – up to the games of the circus, neither more nor less. And something else again, that I will signal for you when the time has come. It is in so far as in this game there is something that, with respect to the 1, is posited as questioning what the 1 becomes when I, o, am lacking to him. And at this point where I am lacking to him, if I posit myself once again as “I”, it will be to question him about what results from the fact that I posited this lack.

It is here that you will have the series that I already wrote as the decreasing series, the one that goes towards a limit, in the series that I do not know how to describe otherwise, the series that is summarised by the double condition which is only one because of being the Fibonacci series, whatever it may be, namely, the relation between 1 and o.

I already wrote the results of this series in this line that continues to infinity, and signalled for you the total of that which, from the value of these different terms, is necessary in the measure that you continue towards the formulae of a decreasing order that culminate at a limit. Culminate if you have started from the withdrawal of o at something that, in totalising the even powers and the odd powers of o, easily realises the 1 as their total.

$$\begin{array}{l} \downarrow \\ 1 - o = o^2 \\ 2o - 1 = \frac{o^3}{1} \end{array}$$

It nevertheless remains that, up to the end, what defines the relationship of one of these terms to the following one, namely, its true difference, is always and in a way that does not decrease but that is strictly equal, the o function.

This is what is demonstrated by the written statement, formulated from (144) this decreasing chain. It is that, whatever may be the appearance linked to the schematisation, it is always the same circle that is at stake. And that this circle, in so far as we ground it, but in an arbitrary, chosen fashion, it is by an act that we posit this Other as field of discourse – namely, what we take care to distance any divine existence from – it is by a purely arbitrary, schematic and signifying act that we define it as One, namely, faith in what? Faith in our thinking. While we know very well that this thinking only subsists from signifying articulation, in so far as it already presents itself in this indefinite world of language. What then are we going to do and what are we doing in the logical order about this circumscribing in which we try to make appear in this all the o as remainder, if nothing more than, by having let it go, by having lost it, by having played in the knowledge of some “the loser wins” or other, to arrive at nothing other than identifying what is involved in the Other itself as o. Namely, by finding in the o the essence of the supposed One of thinking. Namely, to determine thinking itself as being the effect, I am saying more, the shadow of what is involved in the function of the o-object. The o at the point where here it appears to us, deserves to be called the cause, certainly, but specified in its essence as a privileged cause, plays an admirable sense...that play precisely gives us, the play of language in its material form. Let us call it as I already called it more than once on the board the o-cause (*l'a-cause*). Moreover in French does this not make an explosive sound because there exists the expression “à cause de”. And have its resonances always been clearly seen? “A cause de”, does this constitute the avowel that this “à cause de” is only an o-cause. On this every language has its price. And Spanish says “por l'amor”. One could easily take the same effect from it.

But this - at which the limit of time that is imposed on us every time stops me - makes me have to announce to you that I am confirming it. And in confirming it completes the inverted test, namely, the one belonging to the field, to the goal, to the career in which there is

engaged for us the relationship to knowledge. Not that of questioning the One in so far as at the start I put this lack into it and that then I find from the fact that it is identified to this lack itself, but to question this 1 because I am adding this o to it $1 + o$; $1 + o$, such is the first form, such is the upper line as I have written it in the matrix on the right.

What does the $1 + o$ give when it is in its field that there is engaged the radical questioning of knowledge? Knowledge added to the world in so far as, let us say it can, armed with this formula, with this preliminary banner, transform it. What is the logical consequence of it, questioned in the way in which I did it at the level of progressive differences? This is what will perhaps allow us to clarify more radically what is involved in the function of o . Its correlative is in which it is easy to glimpse many things, this thing that the authors were deluded by for a long time, and not just at an indifferent epoch, (145) precisely at the moment when the ontological argument had a sense. Namely, that what is lacking to desire is properly speaking the infinite; perhaps we will say something about it that will give it a different status.

Notice again that the fourth box of the matrix on the right, this zero is found, in the way in which I articulated it by the schema entitled the relationship of S to O, to clearly present the way it is radically distinguished from what is on the first schema, namely, the bet or on the contrary indifference. It well and truly represents the hole and, in a third phase, we will have to demonstrate what it corresponds to in the analysis of what takes its origin in this very hole.

Seminar 12: Wednesday 26 February 1969

(147) You have been good enough to follow me up to the present along narrow paths and I think that, for a number of you, the line I am taking seems to pose the question of its origin and its sense. In other words, it may easily happen that you no longer know very well where we are. That is why it seems an opportune time to me, and not in a contingent way, to pose the question of my title, for example, *From an Other to the other*, under which my discourse for this year is presented. It is indeed in effect conceivable that it is not at the start, by way of a preface, indeed by way of a programme, that something can be elucidated about the end. It is necessary to have travelled at least a bit of the path so that the start is illuminated by retroaction. This not simply for you, but for myself. Since for me this means, in what I might call this drilling operation, which is indeed what interests you, what holds your attention, this means that for at least for a certain number of you who are here, if not for all, I must spend some time to take my bearings in what constituted its stages in the past.

Thus it is that I happened to take up the text – who knows, perhaps with publication in mind – of what I stated ten years ago now, I mean in the seminar 1959-60, it is a long time ago, under the title of *The Ethics of Psychoanalysis*. It gave me some satisfactions of an intimate order to bring to light something that strives to reproduce as faithfully as possible the outline of what I did at that time. This of course, cannot but have all these retroactive effects from what I have stated since, and

specifically here. This is therefore a delicate operation and the only thing that meant I could not keep to the excellent summary that had been done two years later by one of my listeners, namely, Safouan. I would have to give the reasons why I did not publish this summary at that time, but it will rather be the object of a preface to what will come out of it. My satisfaction on this occasion, that you can share if you trust me about the fidelity of the outline that I will try to produce of it, is due to the fact that not only does nothing force me to revise what I put forward at that time but that after all, I can lodge in it, as in a sort of little cup, the more rigorous things, let us say, that I am able to state today about this project.

In effect, what I thought I had to start from during this putting into (148) question, which had never before been done, of what is involved, on the ethical plane, is a new term. This, in a first attempt at an initial drafting that I tried to give of what new things are contributed by what I am stating in the way that seems to me to be the most rigorous, by the Freud event (*l'événement Freud*). I now have, at the date that we are at, the satisfaction of seeing for example as regards what is involved in the function of an author like Freud, I would say that a very broad minded society finds itself in a position of being able to measure his originality and in connection with him, as Michel Foucault did for example last Saturday, in a sort of evil place called the *Société de Philosophie*, in posing the question "What is an author?". And this led him to highlight a certain number of terms that deserve to be stated in connection with such a question, what is an author? What is the function of the name of an author? It was really, at the level of a semantic interrogation properly speaking that he found the means of highlighting the originality of this function and its situation closely internal to discourse. This involves, of course, a putting into question on this occasion, an effect of splitting, of tearing apart of what is involved in it for everyone, namely, for what is called the society of fine minds or the republic of letters, of this relationship to discourse. And whether Freud, in this respect, did not play a capital role, that

moreover the author in question, Michel Foucault, not only accentuated but properly speaking put at the high point of his whole articulation. In a word, "The function of the return to..." he put three dots after it, in the little announcement that he had made of his project of questioning "*What is an author?*". "The return to..." was found at the end, and I must say by that very fact I considered myself as having been invited, there being no one after all, in our day who, more than me, has given weight to "return to..." in connection with a return to Freud. Moreover he highlighted it very well and showed how perfectly well informed he was about the very special sense, the key point that this return to Freud constitutes, compared to everything that is currently a slippage, an alteration, a profound revision of the function of the author, especially of the literary author. And of what in short is provided by this circle in terms of a critical function which, after all, there is no reason to be astonished in our day lags behind, or backwards, with respect to what is happening. Something that in other times, a critical function thought it could pinpoint with this bizarre term that undoubtedly none of those who are in the forefront of it accept but by which we now find ourselves affected as it were by a bizarre label that has been stuck on our backs without our consent, structuralism.

So then ten years ago, in beginning to introduce the question, as I told you, which had never even been raised, which is quite curious, about the ethics of psychoanalysis, assuredly perhaps the strangest thing is (149) this remark by which I thought I should illustrate it, not immediately certainly but I do not even know if I gave enough support at that moment to the thing, I had an audience of psychoanalysts, I thought I would be able in a way to address myself directly by something that must be given a name, when it is a matter of morality, of conscience, add on moral, so I did not remark too much at that stage that the ethics of psychoanalysis as it is constituted by a deontology did not even give a sketch, a beginning, the smallest feature of the beginning of the ethics of psychoanalysis. On the contrary, what I

announced from the beginning is that, through the Freud event, what has been brought to light, the key point, the centre of the ethics is nothing other than what I supported at that time by the final term of these three references, categories, from which I had started my whole discourse, namely, the Symbolic, the Imaginary and the Real. As you know it is in the Real that I designated the pivotal point of what is involved in the ethics of psychoanalysis. I pre-suppose, of course, that this Real is subjected to the very severe interposing, if I can express myself in this way, of the conjoined function of the Symbolic and the Imaginary. And that it is inasmuch as the Real, as one might say, is not easy to gain access to that it is for us the reference around which there ought to turn the revision of the problem of ethics. In effect it is not by chance that, in order to connect it, I started then from the reminder of a work that, even though it has remained a little bit in the shade, and, a curious piece of luck, was only resurrected by the operation of these people that we can consider as not being the best oriented as regards our questioning, namely, those we can call neo-positivists, or again those who believe that they have to question language from the angle of something whose futile destiny I pointed out at one time, to question something that they express in an exemplary fashion, namely, the question put about *the meaning of meaning*, about what is involved in the sense of the fact that these things have a meaning. It is quite certain that this is a path completely opposed to what interests us. But it is also of course not by chance that it should be them, and specifically Ogden who brought out or brought out again, edited rather, this work of Jeremy Bentham called *The theory of fictions*.

It is quite simply the most important work in what is called the utilitarian perspective, and you know that at the beginning of the nineteenth century people were trying to find a solution to the very current problem at that time, and with good reason, an ideological one in a way, described as the sharing of goods. *The theory of fictions* is already at this level, and with an exceptional lucidity, the putting in

question of what is involved in all human institutions. And, properly speaking, nothing could be done, taking things from the sociological angle, that better isolates what is involved as such in this category of the symbolic which is found to be precisely the one that is reactualised, (150) but in a completely different manner, by the Freud event and what came after it. It is enough to understand the term fictions as not representing, not affecting by its domination, what it regards as in no way having an illusory or deceptive character. The way in which the term fictions is put forward does nothing other than overlap what, in an aphoristic way, I promoted by underlining the fact that the truth, in so far as its locus could only be the one where the word is produced, that the truth in essence, if one can express it in this way, forgive me this "in essence", it is to make myself understood, do not give it the whole philosophical stress that this term involves, the truth, of itself, let us say has the structure of fiction.

Here is the essential starting point that in a way allows there to be posed the question of what is involved in ethics in a way that can moreover accommodate all the diversities of culture. Namely, from the moment that we can put them within the brackets, in the parentheses of this term of the structure of fiction, which supposes, of course, reaching a state, acquiring a position with regard to this character in so far as it affects the whole foundational articulation of discourse in what one can call in general social relationships. It is starting from this point, that cannot of course be reached except by starting from a certain limit, let us say once again to evoke our Pascal, all of a sudden, at this turning point I remember him, who therefore dared before him to note simply as something that ought to form part of the discourse that he left incomplete, the one rather legitimately, rather ambiguously also collected under the term of *Pensées*, the formula "truth on this side of the Pyrenees, error on the other side". It is starting from certain degrees of relativism, and of the most radical type of relativism with respect not simply to morals and institutions but to truth itself, that there can begin to be posed the problem of ethics. And it is in this way

that the Freud event shows itself so exemplary. In the fact, as I underlined it and with some support, with some stress in the first trimester of the articulation of the ethics of psychoanalysis, namely, the radical change that results from an event which is nothing other, as we are going to see, than his discovery, namely, the function of the unconscious. It is correlatively that we are going to see later why, in a way that, I think, will sufficiently strike you by its elegance, he made the pleasure principle function in a radically different way to everything that had done up to then. In short, I think that there are enough of you, after all, who have found themselves in one way or another permeated or traversed, let us say, by my discourse that I only need to recall in the briefest fashion what is involved in this principle.

The pleasure principle is essentially characterised at first by this paradoxical fact that its surest result, is not, even though it is written in (151) this form in Freud's text, hallucination, let us say the possibility of hallucination. But let us say that hallucination in Freud's text is its specific possibility. What in effect does the whole apparatus that Freud constructs to account for the effects of the unconscious show us? As you know this is found in Chapter VII of the *Traumdeutung*, when it is a matter of clarifying dream processes, *Traum-Vorgänge*. But we have had the chance, the luck, to see falling into our possession and under our examination what is in a certain way its underpinning in a certain *Entwurf*, in a certain outline that corresponds to these years when, correlatively to the discovery that he was making, guided by these admirable theoreticians that hysterics were – that hysterics are! - guided by them he had his experience of what is involved in the unconscious economy, correlatively he wrote this *Entwurf* to Fliess. A really very developed project, infinitely richer and more constructive than what he thought he could summarise of it, because it is sure that he himself could not fail to preserve a reference to it in this chapter of the *Traumdeutung*. What he constructs at that moment then, under the terms of the psi-system, inasmuch as it is what regulates in the organism the function of what he calls the pleasure principle, let us say

to schematise it roughly, we can put it at the heart of something that is not simply a relay in the organism but a veritable closed circle that has its own laws. And that in order to be inserted into the cycle classically defined by the general physiology of the organism, of the stimulus-motor activity arc, and not response, which is an abuse of the term because response has a sense that ought to have for us a much more complex structure where something is interposed in the function, is defined very precisely not simply by being the hindrance effect imposed on the basal arc but properly speaking creating an obstacle to it, namely, constituting an autonomous psi-system within which the economy is such that it is certainly not the adaptation, the adequation of the motor response that, as you know, is far from being always sufficiently adapted, we suppose it to be free, but everything that happens at the level of the fact that a living animal, in so far as it is defined by the fact of being gifted with a motor activity that allows it to escape too intense stimuli, destructive stimuli that may threaten its integrity, it is clear that what is at stake at the level of what Freud articulates, is that something is lodged as such in certain of these living beings, and not just any ones. And without him being able to say certainly that the same apparatus may be defined simply from the fact that the being in question is a superior vertebrate or something simply provided with a nervous system, it is about what happens properly speaking at the level of human economy that is at stake. And it is at (152) this level, even if from time to time he risks the possibility of interpreting what is happening at the level of other neighbouring beings in reference to what happens in the human being defined in a necessary fashion simply through the consequences and the text of Freud's discourse as a speaking being, it is at this level that there is produced this homeostatic regulation which is defined by the return to perceptual identity. Namely, that in his research, in the broadest sense of the word, in the detours that this system carries out to maintain its own homeostasis, what its functioning ends up with as constituting its specificity, is the fact that what will be rediscovered about the identical perception inasmuch as what regulates it is repetition, what will be

rediscovered does not carry in itself any criterion of reality. It can only be affected by these criteria in a way from outside and through the pure conjunction of a little sign, of something qualificatory that a specialised system already distinguishes from the two preceding ones that you see inscribed in this schema, namely, the reflex circle *qua* constituting the phi-system, the central circle that for its part defines a closed area and constituting the proper type of equilibrium, namely, the psi-system. It is from this afferece of something whose function he closely distinguishes from energetics that can be applied to each of these two systems, and that for its part only intervenes in function of signs qualified through specific periods and which are those afferent to each of the sense organs and that eventually come to affect certain of the perceptats [?] that are introduced into this system of a *Wahrnehmungzeichen*, from a sign that what is at stake here is something that is an acceptable perception with respect to reality.

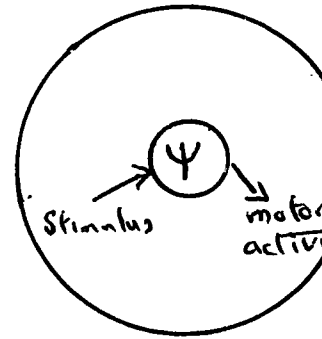

What does that mean? Certainly not that we should approve this use of the term *hallucination* that for us has clinical connotations. For Freud also, certainly, but he no doubt wanted to accentuate very particularly the paradox of the functioning of this system *qua* articulated onto the pleasure principle. Hallucination requires quite different co-ordinates. But moreover we have in a text by Freud himself what constitutes its major reference. It is enough that he refers to exemplify it to the function of the dream to help us find our feet again; it is essentially the possibility of the dream that is at stake. In a word, we find ourselves before this adventure that, to justify what is involved in the functioning of the apparatus that regulates the unconscious in so far as, we are going to recall it later and in the appropriate style, it governs an absolutely essential and radical economy that allows us to appreciate not simply our behaviour but also our thinking. Here the world, in a (153) completely opposite way from what is traditionally the support of philosophers when it is a matter of tackling what is involved in the good of man, here we have the world entirely suspended on the dream of the world.

This means that this step, the Freud event, which consists in nothing other than properly a supposed arrest of what, in the traditional perspective, was considered as the foundation encompassing every reflection, namely, the rotation of this world, celestial rotation so manifestly designated in the text of Aristotle as constituting the referential point where every conceivable good ought to be attached. The radical questioning then of every effect of representation, of any connivance of what is involved in the represented as such, not at all in a subject, let us not say it too early because if in Aristotle this term of *upokeimenon* is put forward exactly in connection with logic, it is nowhere isolated as such. It took a long time and the whole progress of philosophical tradition for knowledge to be organised in its final term, the Kantian term, from a subject relation and something that remains entirely suspended, this is the sense of idealism in so far as there appears, with the *phainomenon*, leaving out the *noumenon*, namely, what is behind, again this representation is comfortable. What is to be underlined in the essence of idealism, is that after all, the thinking being is only dealing with his own measure, that he poses as a terminal point, the referential point that is in question for him. Now it is from this measure that he believes he is able to state in an *a priori* fashion at least the fundamental laws. It is properly speaking in this that the Freudian position differs. Nothing is tenable any longer about what is involved in representation except what is articulated at a point profoundly motivating for behaviour. And this by passing completely outside the circuit of any subject in which the representation is claimed to be unified, to a structure, to a structure made up of a weave and a network. And this is the true sense of these little schemas that the recent discovery of neuronal articulation allowed him to construct. It is enough to refer to this project, to this *Entwurf*, to see the decisive importance in the articulation of what is involved in this trellis, lattice, of this texture and since of course it has not been possible for us for a long time, as already Freud had no doubt a suspicion of, to identify to

these movements, to these transfers of energy that we have been able to map out moreover, by other physical means, to these displacements that happen all along the neuronal texture. It is in no way under this mode that proves from experience to be quite distinct, that we can find the appropriate usage of these schemas that I have just qualified as network, lattice. We see clearly that what Freud used these schemas for, was in a way to support, to materialise in an intuitive form nothing more than what was at stake and that moreover is displayed on the (154) same schemas. At every one of these crossing points it is a word that is described, namely, the word that designates a particular memory. This word articulated as a response, a particular word striking, marking, engraving as I might say the symptom. And what is at stake in these little schemas that I would ask you to refer to – buy *The origins of psychoanalysis*, as a collection of letters to Fliess, to which is joined this *Entwurf*, is translated – and you will clearly see that in effect what Freud found a convenient support from in what was as that time within his hand's reach by what had also just been discovered, namely, neuronal articulation, was nothing other than the articulation, under the most elementary form, of signifiers and of relations that can be fixed in a way that, in our day the same schema that would have the same shape. Buy the last little book that has appeared, or rather buy *The axiomatic theory of sets* by M Krivine. You will see there exactly Freud's schemas except for the fact that what is at stake are little schemas oriented more or less like this, and that are necessary to make us understand what is involved in set theory. This means that every point, in the measure that it is linked by an arrow to another, is considered in set theory as an element of the other set. And you will see that it is a matter of nothing less than what is necessary to give a correct articulation to what is most formal in order to give its foundation to mathematical theory. And already you will see there, by simply reading the first lines, what is involved in every axiomatic step that is taken. Namely, the veritable necessities taken from the formal angle in what is involved in a signifying articulation taken at its most radical level. Notably this particularly

exemplary one, the notion defined there of a part concerning its elements, elements that are always sets, the way it is said that one of these elements is contained in another, depends on these formal definitions which are such that they are distinguished, that they cannot be identified to what a term like “be contained in”, intuitively means. Because if you suppose that I make a schema that is a little more complicated than that one and that I write on the board as a note “the identification of each one of these terms in the set (*ces termes ensemblistes*)”, it is not at all enough that one of them is written, namely, constitutes in appearance a part of the universe that I am establishing here, for it to be able in any way to be said that it is contained in any of the other terms, namely, to be an element of it. In other words what is articulated from a configuration of signifiers in no way signifies that the entire configuration, that the universe thus constituted can be totalised. Quite the contrary, it leaves outside its field as not being able to be situated as one of its parts, but only articulated as an element in a reference to others, the sets thus (155) articulated. It leaves the possibility of a non-coincidence between the fact that intuitively we might say that it is part of this universe and the fact that formally we can articulate it to it. This indeed is an altogether essential principle and is the one through which mathematical logic can essentially instruct us, I mean allow us to put in their correct place what is involved for us about certain questions. You are going to see which ones.

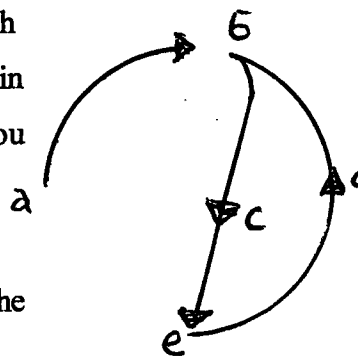

This minimal logical structure as it is defined by the mechanisms of the unconscious, I have for a long time summarised under the terms of difference and repetition. Nothing else grounds the function of the signifier except its absolute difference. It is only in the way that the other signifiers are different from it that the signifier is sustained. On the other hand these signifiers should be and function in a repetitive articulation. This is the other part of what is involved in the other characteristic, that a first logic can be established from what on the one hand results from this signifying pinpointing itself, not to fix but on the

contrary to slide, that what fixes is a reference to the signifying pinpointing, is destined to slide from this pinpointing itself. Here is the fundamental function of displacement. That on the other hand it is of the nature of the signifier *qua* pinpointing to allow the substitution of one signifier for another, with certain expected effects that are effects of sense. That is the other dimension. But the important thing is the following and it is appropriate for us to accentuate it here to allow us to grasp what is really involved in our functions, I mean psychoanalytic functions. If at the level of the possibility of the dream, namely, of this pleasure principle through which essentially and at the start the function of the reality principle is constituted as precarious – certainly not cancelled out for all that but essentially dependant on the radical precariousness to which the pleasure principle subjects it – what must be grasped is the fact that what we see in the dream, since at the start it is here that there takes place essentially the approach of this function of the signifier, of this minimal logical structure whose terms I articulated again just now, there must be pushed to the end what is involved in the Freudian perspective. If, as everything seems to (156) indicate in our way of treating the dream, what is involved are sentences – let us leave aside for the moment the nature of their syntax – they have an elementary one at least at the level of the two mechanisms that I have recalled of condensation and of displacement. What must be seen, is that the way in which it appears hallucinatory for us, with the accent that Freud gave to this term at this level, what does it mean if not that the dream is already in itself interpretation, a wild one certainly, but interpretation. It is there besides that it can be grasped that this interpretation, which is to be taken as Freud himself quite calmly wrote – if I have underlined it, I am certainly not the one who discovered or invented it in the text – that if the dream is present as a rebus, what does it mean if not that to every one of these articulated terms that are signifying from a diachronic point of its progress where there is established its articulation, the dream, through its function, and the function of pleasure, therefore this imaged translation that itself only subsists because it can be articulated in a

signifier, what do we do then in substituting for this wild interpretation our reasoned interpretation? On this it is enough to invoke the practice of each person but for the others, let them re-read in the light of this the dreams quoted in the *Traumdeutung* in order to grasp that what is at stake, is in this reasoned interpretation, nothing other than from a reconstituted sentence, to grasp the point where there is a flaw which is the one where, *qua* sentence, and not at all *qua* meaning, it allows there to be seen what is not working, and what is not working, is desire.

Take the dream, something really exemplary, and in a way put by Freud at the very start of the chapter where he questions dream processes, the *Traum-Vorgänge* and in which he tries to give what he calls their psychology. There you will read the dream of "*des alten Mannes*", of the old man that tiredness had forced to abandon in the room next door the body of his dead son to be watched over by another old man. What he dreams about, is about this son standing, alive, who comes close to his bed, who grasps him by the arm and in a voice full of reproach says: "*Vater, siehst du denn nicht dass ich verbrenne?*", father, do you not see I am burning? What could be more moving, what could be more pathetic than what happens. Namely, that the father awakes and going into the next room sees that effectively a candle has fallen over and has set fire to the sheets that are already licking at the body while the watcher has fallen asleep? And Freud tells us that undoubtedly apart from the fact that the dream was only there to prolong sleep in the face of the first signs of what had been perceived of this horrible reality, do we not further grasp that it is precisely by considering that reality overlaps this dream that proves that the father is still sleeping. Because how can we not understand the accent there is in this word when Freud tells us moreover that there is no word in the dream that has not come somewhere in the text of (157) words effectively pronounced. How can we not see that it is a desire that burns this child, but in the field of the Other, in the field of the one to whom he addresses himself, to the father on this occasion? What is at stake is some flaw that comes from the fact that he is a

desiring being, some flaw he had shown with respect to this beloved object that his son was. And that it is from this which, Freud tells us, is not analysed but very sufficiently indicated, it is from this that reality itself protects him, in its coincidence. The interpretation of the dream is not in any case, and Freud agrees with this, what caused it in reality.

So then, when we interpret a dream, what guides us, is certainly not “what does that mean?” nor is it “what does it mean in saying that?” but “what by saying that does it wish?” Apparently it does not know what it wants. Here indeed is where the question lies and our formulae, in so far as they establish this first relationship linked in a way to the most simple function of number in so far as it is generated from this most elementary something that has a name in mathematics and that is called a sub-group where there intervene additions, what I called the Fibonacci series, simply the joining up of the two preceding terms to constitute the third: 1 1 2 3 5 ... that it is from that very place, as I told you, that there is generated this something that is not of the order of what is called the mathematical, the rational, namely, this unary trait, but something that, at the origin, introduces this first proportion, the most original one of all that we have designated and that is designated in mathematics where it is perfectly well known:

$$o = \frac{\sqrt{5}-1}{2}$$

simply by this proportion $o/1-o = 1/o = 1+o$.

Now at the place of o , write knowledge. We do not know yet what it is since this is what we are questioning ourselves about. If 1 is the field of the Other and the field of truth, the truth in so far as it does not know itself, we write:

$$\frac{\text{knowledge}}{\text{truth} - \text{knowledge}} = \frac{\text{truth}}{\text{knowledge}} = \text{truth with knowledge added}$$

o.7

Let us try to see what these relationships mean. This means that knowledge about the unconscious, namely, that there is a knowledge

that says "there is somewhere a truth that does not know itself" and it is this that is articulated in the unconscious, it is here that we ought to find the truth about knowledge. Does our relationship, the one that we made earlier, between the dream – I am isolating it from the totality of the formations of the unconscious – this is not to say that I could not (158) also extend it but I am isolating it for clarity, this role of which we may wrongly pose the question "what does that mean?". Because this is not what is important, it is where is the flaw in what is said? This is what is important for us. But it is at a level where what is said is distinct from what it presents as meaning something. And nevertheless it says something without knowing what it is saying since we are forced to help it by our reasoned interpretation. To know that the dream is possible, that is to be known, and that this is how it is. Namely, that the unconscious should have been discovered, is what indicates to us the singular proportion that we can write with the help of the term *o qua* original effect of the inscription itself, provided we simply give it this little push of being able to renew itself by connecting repetition and difference in this minimal operation called addition.

It is there that, inasmuch as in this register it is written $o/1-o = 1/o$ we can see that this knowledge about the diminished truth of knowledge, it is there that we have to take not simply the truth, namely, a word that is affirmed, truth about what is involved in the function of knowledge, but even on this occasion to be able to confront them on the same line and, in a word, to question what is involved in this junction which ensures that we can write truth plus knowledge.

Now all I am able to do, since I am pressed for time, is to recall the economic analogy that I introduced here about what is involved in truth as work, an analogy that is very sensitive to something in our experience. The fact is that a discourse, at least the analytic one, the work of truth is more obvious because it is painful. To make one's way without falling to the right or to the left into some intuitive

identification or other that short-circuits, in a way, the sense of what is at stake in the least relevant references, that of need for example. And on the contrary, it is to the function of price that I homologated knowledge. Now price is certainly not established by chance, any more than any effect of exchange. But what is certain, is that the price in itself does not constitute a work and here indeed is the important point. It is that neither does knowledge, whatever may be said about it. It is an invention of pedagogues that knowledge is acquired by the sweat of your brow, we will soon be told, as if it were necessarily correlative to burning late oil. With good electrical light one can do without it! But I ask you: have you ever, I am not saying learned anything, because to learn is a terrible thing, you have to go through all (159) the stupidity of those who explain things to you. This is painful to bring up, but is it not a fact that getting to know something always happens in a flash?

Everything that is said about any learning by experience, having something to do with one's hands, knowing how to handle oneself on a horse or on skis, that has nothing to do with knowledge. There is a moment when you know how to sort out the things that are presented to you, which are signifiers, and in the way that they are presented to you, it means nothing. And then all of a sudden it means something and that from the very beginning. It is tangible from the way in which a child handles his first alphabet that what is in question is not any learning but the collapse that unites a big capital letter with the shape of the animal whose initial is supposed to correspond to the capital letter in question. The child makes the connection or does not make it. In the majority of cases, namely, in those where he is not surrounded by too much pedagogical attention he makes it. And that is what knowledge is. And every time a piece of knowledge is produced, of course, it is not useless for a subject to have passed through this stage in order to understand what happens from an effect of knowledge in the little schemas that I feel scrupulous about not having made you

sense properly earlier on, but I was pressed for time, set theory. We will come back to it if necessary.

What is it to know? If we ought, pushing things further, to question what is involved in this fundamental analogy, the one which means that knowledge still remains perfectly opaque because it is a matter for the numerator of the first relation of a singular knowledge which is the fact that there is truth, and perfectly articulated to what it lacks *qua* knowledge. And that, by reason of this relation, it is from this very relation that we are expecting the truth about what is involved in knowledge. It is clear that I am not leaving you here at the level of a pure and simple riddle and that the fact that I have introduced it through this term *o* shows you that it is effectively in the articulation that I already, it seems to me, sufficiently circumscribed about the *o*-object that there ought to depend any possible manipulation of the function of knowledge.

Will I here, at the moment of ending, need to have the necessary boldness to give a plausible sense to what will be written in terms of a cross conjunction of the type that people use in arithmetic. From this knowledge about the unconscious to this knowledge questioned as a radical function. In so far, in short, as it constitutes this very object towards which there tends every desire in so far as it is produced at the level of articulation. How knowledge *qua* knowledge is lost at the origin because desire appears in every possible articulation of discourse. This is what we will have to consider in the talks that follow.

Seminar 13: Wednesday 5 March 1969

I left you the last time on a formula balanced according to what we will call a harmonic proportion that I developed before you in these terms that

$$o/1-o = 1/o$$

which I was able to translate easily, because of what had been previously said, by something that carries in itself a certain degree of obviousness and is of a nature to satisfy by an *a priori* formula what is commonly accepted as being what the analytic conquest is. This is the fact that we know that somewhere, in this part that we call the unconscious, a truth is stated which has this property that we can know nothing about it. This, I mean this very fact, is what constitutes a knowledge. I therefore wrote: knowledge over the function of truth minus knowledge, this is what ought to give us the truth about knowledge.

$$\text{Knowledge/Truth} - \text{Knowledge} = \text{Truth/Knowledge}$$

At this point, to give you notice of a tiny episode among my encounters, I happened this week to hear a formula – I apologise to its author if I distort it a little. It was a matter of a formula at the beginning of a research into the line of my teaching, which was to situate the function of psychoanalysis not at all costs as a science but as an epistemological indication. Since research on the function of science is on the agenda, the formula is the following:

“Psychoanalysis is supposed to be, in the sciences, something that one could formulate as a science without knowledge”. My interlocutor went as far as that. And carried along no doubt by what is involved in a certain current movement, in so far as at a level that is indeed also one of experience, there is posed a question of what is involved in terms of a sort of relativity that is accused of being the style of social domination in the transmission of knowledge. I took up my interlocutor sharply, precisely in the name of the fact that it is false to say that nothing of psychoanalytic experience, that nothing in a (162) teaching could be properly articulated, be put forward as knowledge. And that because of that fact, because this is what is at stake at present, able to be stated in a magisterial fashion in the terms that are precisely those in which I state this knowledge here. And nevertheless from a certain angle, in a certain fashion, what my interlocutor was putting forward was the truth.

It is the truth at the level of this analytic knowledge that is not one, of knowledge, as compared to what it seems to be. What one might take it for if, under the pretext that it has stated the original, radical relationship of the function of knowledge to sexuality people precipitated themselves too quickly – this is a pleonasm! – to deduce from it that it is a knowledge about the sexual. Who has ever learned in psychoanalysis how to treat his wife properly? Because it is a fact that a wife counts! There is a certain way of taking her from the right angle, she is to be held in your arms in a certain way and she for her part has no doubt about it! She is capable of saying to you: “You are not holding me the way a woman should be held”. That in an analysis the paths that prevented this man, to whom this woman was addressing herself in the way I have just said, from doing it properly can be clarified, is what people like to believe happens at the end of an analysis. And as regards technique, if you will permit me to express myself in this way, the result depends on his natural knowledge, his skill (*adresse*), if you will allow me to use this word, with all the ambiguity it possess in French from the ordinary resources of the

language: the faculty pinpointed by this name and also the sense of whom that is addressed to, the address that is supposedly given at the end of a certain clearing out.

It is clear that there is nothing in common between the analytic operation and anything whatsoever pertaining to this register that I have just now called technique. Its extent can be measured when one maps out this domain, as Mauss did incidentally, for example, speaking about the characteristics in culture of this very widespread function, for which it is not without reason that in our civilisation, it is not properly speaking eluded but repressed into corners, this function he calls "the techniques of the body". I have here only to make an allusion to the dimension of properly erotic techniques in so far as they are put forward in one or other culture that one could not in any way describe as primitive, the Hindu culture for example, to make you sense that nothing of what is stated in what for you, in no case reaches you except under the heading of playthings, of pornography, in reading a book like the Kama-Sutra for example. And nevertheless, in another dimension that this text can be understood, it can take on an import that, with regard to the complete confusions about this word, the one that I am going to use, will be mapped out, not incorrectly, but approximately, as metaphysical. The angle then from which sexual knowledge is tackled in psychoanalysis, is why it takes on its weight in (163) the way that I write it. There again, once more, what is at stake, is a recourse to what is obvious from the start, and this is indeed the prohibition properly speaking that can cover this knowledge, sexual knowledge. The angle from which I would not say we enter into it but are confronted by it, is again the following, in the sense that this angle was never taken. It is to tackle it from the point where this prohibition is brought to bear, and that is why the first statements of Freud with respect to the unconscious put the accent on the function of censorship as such.

This prohibition is exercised as affecting a certain “there”, that place, where it speaks, where it avows itself, where it avows that it is preoccupied by the question of this knowledge. And admire there, in passing, once again the riches of language. Is not this “preoccupied” to translate *Besetzung*, the Freudian *Besetz*, not better than this “investment” or this “invested” that the translations deafen us with? It is pre-occupied, occupied in advance by this something whose position, henceforth, is going to become more ambiguous. What can be meant – and this is what requires us to return to it again, to this function of the unconscious – what can be meant by this knowledge whose mark at a certain level that is articulated from truth is defined by the fact that this knowledge that preoccupies you is what you know least. And this is what allows us to state perhaps, to clarify things that one can say from a certain point of view, that in our culture, our civilisation, in our sauce, for this frying pan or in any case it is indeed the only term that justifies this gathering here, one could go as far as to sustain that psychoanalysis has this function of maintaining this sort of hypnosis which means that after all, it is quite true, huh, among us the sexual is maintained in an unprecedented torpor.

All of this is not a reason for psychoanalysis to be used in any way to contest - because this is what is at stake - the well-foundedness of the transmission of any knowledge whatsoever, not even its own. Because after all it discovered something, however mythical its formulation, it discovered what in other registers is called the means of production, of what? Of a satisfaction. It discovered that there was something articulatable and articulated, something that I pinpointed, that I exposed as *montages*, and literally not being able to conceive of itself otherwise, that it calls the drives. And this only has meaning – which means that it does not present them as such – in as far as on occasion it is satisfying, and that, when one sees them functioning, that implies that it brings satisfaction with it. When, from the angle of a theoretical articulation, it exposes in behaviour the functioning of oral drives, anal drives, and of others again, scopophilic or sado-masochistic drives, it

is indeed to say that something is being satisfied and it is self-evident that it cannot be designated otherwise than as what is underneath, a subject, an *upokeimenon*, whatever division must necessarily result for (164) it, because here it is only the subject of a functioning instrument, an *organon*. The term is used here less with an anatomical accent, a prolongation, the more or less animated natural appendix of a body, than properly in its original sense, where Aristotle, uses it in logic as an apparatus, as an instrument. Naturally, the domain is no longer limitroph. And it is indeed because of this that some organs of the body that are moreover ambiguous in different ways, hard to grasp, because it is too obvious that some are only waste products, are found to be placed in this function of instrumental support. So then a question is opened up. How can we define this satisfaction? We have to believe that there must here be something, all the same, that is not working because what we spend our time on, with regard to these *montages*, is dismantling them. Does that mean that the pure and simple dismantling implies in itself, as such, in the foreground, that it is curative? If that was how things were, things might have gone a little quicker, and we would perhaps have covered the whole area a long time ago! If we put forward the function of *fixation* as essential, it is indeed because the affair is not so easy as that. And that what we have to retain in the psychoanalytic field is perhaps in effect that there is something that is inscribed as its horizon, and that this is the sexual. And that it is in function of this horizon, maintained as such, that the drives are inserted into their function as system.

You see then the prudence with which I am bringing forward my assertions here. I spoke about horizon; I spoke about field. I did not speak about sexual act, since moreover for those who were already here two years ago, I posed for the question of the act different premises, undoubtedly, than those that take it as a given that there is a sexual act. They will remember that I concluded that by taking as an aim the question of the sexual act, we can state that by taking the act with the structural emphasis where alone it subsists, there is no sexual

act. We will come back to it. Moreover, you can be sure that it is indeed in order to return to it from another angle, that of this year, the one that goes from an Other to the other, that we find ourselves on this path where there deserves nevertheless to be recalled what we concluded using a different approach.

What is questioned about satisfaction as essential to the drive we are also forced to leave in suspense, if only in order to choose our path in order to be able to define it. For the moment we can make the leap from the living experience that is found somewhere at the level of the equals sign of the equation written here. Here indeed is what is at the centre of our questioning today. To what satisfaction can knowledge itself correspond, a knowledge that it is not for nothing I am, in short, putting forward here as notionally approachable, as the knowledge that will be identical to this field that I have just circumscribed, which would be “knowing one’s way around, *savoir y faire*” in this field. Is (165) this even enough? This knowing one’s way around it is still a little too close to know-how (*savoir faire*), about which there may have been earlier a misunderstanding that I encouraged, moreover, as a way of catching you where you have to be caught, in the gut. It is rather “knowing how to be with it, *savoir y être*”, and this brings us back to the angle that is in question for us here. This always brings us back, as it should, to the basis of what is at stake for us. That what the Freudian discovery puts forward is that one can be with it without knowing that one is with it. And that to believe oneself more certain by being wary of this being with it, to believe oneself to be elsewhere, in a different knowledge, means one is fully in it. This is what psychoanalysis says, one is in it without knowing it; one is in it in all the fields of knowledge. And that is why it is from this angle that psychoanalysis is found to be important for putting knowledge in question. It is nowhere from any truth and specifically not from any ontology. Wherever one may be, wherever one functions, through the function of knowledge, one is in the horizon of the sexual.

You must admit that it is all the same worth the trouble to look more closely at this. One is in it without knowing it. Does one lose oneself in it? There seems to be no doubt about that, because that is what people start from. One is screwed up to the hilt. The dupery of consciousness lies in the fact that it is used for something that it does not think it is used for. I said dupery, not deception. Psychoanalysis does not question itself about the truth of the matter. Nowhere can we extract from it discourses about the veil of Maya or about the fundamental illusion of the *Wille*. Dupery implies something, but it is here less easy to resolve than elsewhere. A dupe, is someone that someone else exploits. Who exploits here? The accent being put on dupery, all the same the question spreads out (*fuse*). And that is why in a zone which is the continuation of Marxist theory, there is some unease. Might this bloody psychoanalysis not give here – this is the term that I heard advanced like that, emerging in these words, I prefer, as I told you, a discourse without words but when I go to see people it is in order to talk, so they talk, they talk more than me, and then they say something like that: “After all, psychoanalysis might well be a further guarantee for the theory of social exploitation”. They are not wrong; only here the exploiter is less easy to grasp; the style of revolution also. It is a dupery that benefits no one, at least in appearance.

So then is the knowledge of analytic experience only the knowledge that can be used not to be a dupe to the tune that is being played? But what use is it if it is not accompanied by a knowledge of how to get out of it or even, more specifically an introit knowledge, knowing how to enter into what is in question as regards this flash that can result from it because of the necessary failure of something which is perhaps not the privilege of the sexual act. It is this question about which psychoanalysis, in fact, has remained on the threshold. Why has it remained on the threshold? The fact that it remains on the threshold in

(166) practice, is something that can only be justified in a theoretical way. This is what we are striving for. But that it should also have remained there on the theoretical plane is, I would say, its problem. Let us leave it to get out of it by itself; that does not prevent us, all of us as we are here, in so far as we are in the frying pan, from trying, we also, like the others, to go further.

It is certain that here, precisely, we find ourselves at the crossroads where, in a completely inverse way to what I stated earlier, we have perhaps to learn from the experience of other dimensions with regard to a certain text which proves with time not to be too different to ours, since the function of the sign and even of the signifier here has its own value, namely, the Marxist critique. It would perhaps be enough for a little bit less belief in progress on one side and the other for us to arrive at fruitful conjunctions - I mean theoretical ones. On this point, everyone knows that I am contributing something that is also an *organon*, precisely the one that may be of use to cross this frontier, and that some people pinpoint as the logic of the signifier. It is true, I managed to make some statements about this. And they stimulated in a lively way minds that nothing coming from psychoanalysis had prepared, but who found themselves stimulated by things that came from elsewhere. Elsewhere, which is not so simple to specify, because it is not simply a matter of political allegiance. But, moreover, a certain number of styles that in the present time, namely, well after I began to state the aforesaid logic, there were produced all sorts of questions about the handling of this signifier, about what a discourse is, about what a novel is, even about what the proper use of formalisation in mathematics is. So people are, there as elsewhere, in a bit of a hurry. Haste has its function, I already stated the logic of it. Again I only stated it to show the mental traps, I would go as far as to qualify them as such, into which it precipitates. People will end up, by wanting to accentuate the degree to which what I am stating as a logic

of the signifier remains in the margin, in some way, of what a certain frenzy, adherence to pure formalisation would allow to separate out from it as, they say, metaphysics. We will end up with the notion that, even in the domain of pure mathematical exercise, the use of formalisation does not exhaust everything but leaves in the margin something in connection with which the question about what is involved in the desire to know is still valid. And, who knows, someone around me suggested it a few days ago, there will be perhaps despite myself one day in mathematics something that will be called the Lacan theorem! It is certainly not what I would have looked for, because I have other fish to fry, but this is precisely the way these things happen. By wanting to consider as closed – and this is indeed a characteristic of something that normally ought to end up elsewhere – an uncompleted discourse, one produces waste products like that. One (167) can still leave the statement of this theorem to an obscure future.

For the moment, let us come back to knowledge and let us start again from what is being stated here. It is not the same thing to state a formula if you start at one end rather than the other. Knowledge, one can say, contrary to our experience, is what truth lacks. That is why truth – which obviously, just by that, puts out of synch the debate of a certain logic, the logic of Frege in so far as it starts on the two crutches of two very notable values, 1 or 0, truth or error. Observe carefully the trouble he has in finding a proposition that he can describe as truthful. He has to invoke the number of satellites that Jupiter or some other planet has. In other words something nice and round that can be isolated, without noticing that this is only to have recourse to the oldest prestige of the way the real first appeared as what always comes back to the same place. Because he cannot advance anything other than the recourse to these astronomical entities, because of course there is no question of a mathematician stating as a formula bearing inherent to itself the truth of 2 and 2 are four. Because it is not true if by chance in

each of the 2 there was one that was the same. They would only add up to 3. There are not many other formulae that can be stated as truth.

That the truth is the desire to know and nothing else is obviously only designed to put in question precisely the following, whether there was a truth before? Everyone knows that this is the sense of the Heideggerian *letting be*; is there something to *let be*? It is in this sense that psychoanalysis contributes something. It is there to say that there is something, in effect, that one can let be. Only it intervenes in it. And it intervenes in it in a way that interests us, beyond the threshold behind which it lies, in so far as it makes us question ourselves about what is involved in the desire to know.

That is why we come back to the drive. It is no doubt mythological, as Freud himself wrote. But what is not so, is the supposition that a subject is satisfied by it. Now it is not thinkable without the implication already, in the drive, of a certain knowledge, of its character of taking the place of the sexual. Only there you are, what does that mean, that it is not thinkable? Because things can go as far as to question the effect of thinking as suspect. Perhaps we know absolutely nothing about what that means, to take the place of the sexual (*tenir lieu du sexuel*). The very idea of the sexual can be an effect of the passage of what is at the heart of the drive, namely the o-object. As you know, that was done a long time ago. Dear Eve passed him the fatal apple! After all, this is also a myth. It is starting from there that he sees her as a woman. He becomes aware of all the things I told you about earlier. Beforehand, he had not noticed that she was (168) something extracted from the side of his ribcage. He found it, like that, nice, very agreeable. They were in Paradise! It is probably at that very moment – and in reading the text there is no doubt about it – that not only does he discover that she is the woman, but he begins to

think, the little dear! That is why that to say "it is not thinkable" that the drive already involves, implies a certain knowledge, does not take us very far. And the proof, moreover, is that here is the connecting point with idealism. There was someone called Simmel who spoke, in his time, about sublimation, before Freud. It was in order to start from the function of values. And so then he explains very well how the feminine object comes to take on, within this, a privileged value. It is a choice like any other. There are values, one thinks in values; and then one thinks in accordance with values; and then one builds up values.

I told you that psychoanalysis and Freud are not worried either about illusion nor the veil of Maya, it is precisely because one and the other, the practice and the theory, are realist. Enjoyment is something that is only noticed by seeing how constant it is in Freud's statements. But it is also what is noticed from experience, I mean psychoanalytic. Enjoyment is here an absolute, it is the real, and in the way that I have defined it as what always returns to the same place. And if one knows it, it is because of the woman. This enjoyment as such is such that originally only the hysteric puts it in order logically, it is she in effect who posits it as an absolute, that is why she unveils the logical structure of the function of enjoyment. Because if she posits it in this way, which makes her a correct theoretician, it is at her own expense. It is precisely because she posits it as an absolute that it is rejected, and can only respond to it from the angle of a desire unsatisfied with respect to herself.

This position in logical unveiling starts from an experience whose correlation is perfectly tangible at every level of analytic experience. I mean that it is always from a beyond of enjoyment as an absolute that all the articulated determinations of what is involved in desire logically

find their correct place. This reaches a degree of consistency in the statements that refutes all the out-of-datedness linked to the randomness of origins. It is not because the hysterics were there at the start through a historical accident that the whole affair was able to take its place. It is because they were at the right point where the incidence of a word could highlight this hollow which is the consequence of the fact that enjoyment plays here the function of being outside the limits of the game. It is because as Freud says, the enigma of what a woman wants is there, which is an altogether displaced way of pinpointing what is involved, on this occasion, about her place, which takes on its value from what a man wants. That the whole theory of analysis, as is sometimes said, has developed along an androcentric channel, is certainly not the fault of men, as is believed. It is not because they are (169) dominant, in particular, it is because they have lost their way and that from then on, it is only women, and especially hysterical women, who understand something about it.

If in the enunciation of the unconscious as I have written it, the mark of \circ is raised to the level where knowledge is lacking, it is in the measure that we know nothing about this absolute and this is even what constitutes it as absolute. It is because it is not linked in the statement but that what is affirmed, and this is what stating is in its unconscious part, is that this is what desire is *qua* lack of the 1. Now this does not guarantee that this is what desire is *qua* lack of the 1. This does not guarantee that the lack of the 1 is the truth. Nothing guarantees that it is not the lie. That is even why in the *Entwurf*, in the *Project for a scientific psychology*, Freud designates what is involved in the unconscious concatenation as having its start in a *proton pseudos*, which can only be translated correctly, when one knows how to read, by the sovereign lie. If that is applied to the hysteric, it is only in the measure that she takes the place of the man. What is at stake, is the function of this 1 in so far as it dominates everything that is

involved in the field that has correctly been pinpointed as metaphysics. It is what is put in question much more than being by the intrusion of psychoanalysis. It is what has forced us to displace the accent from the sign to the signifier.

If a field were conceivable where sexual union functions, it would only be a matter, where it appears to work, in the animal, of the sign. "Make me a swan (*cygne*)", as Leda said to one of them! After that, everything is fine. Each one has been given a half of the dessert, we are united, that makes One. Only, if analysis introduces something, it is precisely that this One does not work. And that is why it introduces something new, in the light of which moreover even the exploits of eroticism that I made an allusion to earlier, in so far as it engages with them, can alone take on a meaning. Because if sexual union, at the same time, only involved its goal of satisfaction, there would be no subjective process to be expected from any experience. By which I mean not those that, in analysis, give the configurations of desire, but those that, well beyond, in a terrain that is already explored, already practised, are considered to be the paths of an asceticism where something of the order of being can come to be realised. Enjoyment, this enjoyment that is here only highlighted from the exclusion in a way of something that feminine nature represents. Do we not know that nature does not always seem to need to have recourse to it, in order to provide for the necessity of union in its thousands and ten of thousands of species? There are many other systems other than tumescent systems that function in particular arthropoda or arachnida. What is involved in enjoyment can in no way be reduced here to a (170) naturalism. The naturalistic aspect of psychoanalysis is simply this natural aspect of the systems that are called drives, and this natural aspect is conditioned by the fact that man is born into a sea of signifiers. There is no reason to give it any consequence at all in the sense of nature worship.

The question that we are going to open up and which will be the object of our next talk will be clarified, I think, by these premises that I put forward today. How can it happen – it is from here that the question should be taken up - not that sublimation, which is the point where Freud himself marked what I called earlier the coming to a halt of analysis on a threshold. About sublimation he has only told us two things: that it had a certain relationship *an Objekt*. *Am, an*, you already recognise the *an sich*. It is not at all the same as the French *en*. When the *an sich* is translated by *en soi*, it is not that at all. This indeed is why my “*en-je*” when it is the *o* that is at stake is also ambiguous. I would have liked to have called it “*o-je*”, putting in an apostrophe, *l’o-je*”, and you will see immediately in this way where we are sliding. This is the correct use of tongues in practice. But, to take up again what is involved, when Freud articulates sublimation, he underlines that if it has a relationship with the object it is through the intermediary of something that he exploits at the level at which he introduces it and that he calls idealisation. But that, in its essence it is *mit den Trieb*, with the drive. This is in the *Einführung zur Narzissmus*. But to refer you to other texts, there are a certain number, I do not think that I need to enumerate them for you, from the *Three essays on sexuality* to *Group psychology*, the accent is always put on the fact that as opposed to the censoring interference that characterises *Verdrängung*, and, in a word, from the principle that creates an obstacle to the emergence of work, sublimation is properly speaking and as such a mode of satisfaction of the drive. It is with the drive, a drive that he qualifies as *zielgehemmt*, diverted, people translate, from its goal. I already tried to articulate what is involved in this goal, and that perhaps it is necessary to dissociate at the level of the goal what is the path for what is properly speaking the target in order to see more clearly into it. But what need for such quibbling after what I have produced before you today. How can it not be seen that there is nothing easier than to see the drive being satisfied outside its sexual goal. However it may be defined, it is outside the field of what is defined in its essence as the system of the drive.

In a word, to conclude, I would only ask one thing of you, to see where it has ended up everywhere when, not through instinct, that we would have a lot of trouble from today on to situate somewhere, but a social structure that is organised around the sexual function. We may be astonished that none of those who have applied themselves to showing us the society of bees or of ants have not put the accent on the fact that while they are occupied with quite different things, with their groupings, with their communications, with their revels, with their (171) marvellous little intelligence, to see that an anthill like a hive is entirely centred around the realisation of what is involved in the sexual relationship. It is very precisely in the measure that these societies are different from ours, that they take on the form of a fixedness which proves the non-presence of the signifier. This indeed is why Plato, who believed in the eternity of all relationships between ideas, created an ideal *Politeia* where all the children are in common. From that moment on, you are sure of what is involved, it is a matter of properly speaking centring society on what is involved in sexual production. The horizon of Plato, however idealistic you may imagine him to be, was nothing else, except of course a sequence of logical consequences of which there is no question that they carry in their fruits to cancel out in society all the effects of his dialogues. I will leave you with this for today and I am giving you a rendezvous the next time on the subject of sublimation.

Seminar 14: Wednesday 12 March 1969

(On the board)

The Woman?

The Other?

The Thing?

X

The locus of the word
with which one
makes love

the vacuole of
enjoyment

Enjoyment

The object
(otolithic)



Sublimation to reach the Woman
courtly love, the idealisation of the object
Sublimation to reach Enjoyment
with the drive
The representative of representation.

(173) I put some little words on the board so that they may serve you as hooks for some of the remarks that I will make before you today. In fact, with the time that has passed, that ought to be enough for you! I mean that starting from these hooks that figure on the first line, question marks, I ought to be able to hand over to at least some of you

so that they can carry out in my place this weekly work that consists in drilling into this discourse. In truth, it would not be a bad thing for people to take up the baton. I mean that, as has been done moreover in previous years, there should be people who are willing to devote themselves to pushing further along a certain number of subsisting objects, that it would be no harm to bring up to date after a certain lapse of time.

(174) It is quite obvious in effect that in what I state, there are phases, levels, especially if you think of the point from which I had to start in order first of all to hammer home this point that was nevertheless clearly visible in what I occupy myself with. Namely, that the unconscious, I mean the unconscious that Freud speaks about, is structured like a language. This is visible to the naked eye, there is no need for my spectacles to see it but in fact they were necessary. A friendly person said to me recently that reading Freud, in short, is too easy, because one can read him and be completely hoodwinked. After all, why not, because taking things in the round, this has been clearly proven by the facts. And the first massive thing, the one that people had to disentangle themselves from had not even been noticed, thanks to a sequence of configurations that one can call the operation of popularisation. Nevertheless time was necessary for me to get it across, and this even in the circle that in this respect had been most alerted to notice it.

Thanks to all these delays things happen that I cannot say are discouraging for me, far from it. It happens, for example, that a M Gilles Deleuze, continuing his work, has brought out in the form of his theses two capital books the first of which is of the greatest interest to us. I think that simply from its title *Difference and repetition*, you can see that it ought to have some relation with my discourse, of which of course he is completely aware. And because like that, without any delay, I had the happy surprise to see appearing on my desk an additional book that he is giving us. This moreover is a real surprise

because he had not announced it in any way to me the last time I saw him after passing his two theses. It is called *The logic of sense*. It would be no harm all the same for someone, for example, among you to get to know a part of this book. I am not saying the whole thing because it would be a lot to bite off, but in any case it is constructed in a way that a book ought to be constructed. Namely, that each of its chapters implies the whole, so that by taking a well chosen part, it would not be a bad thing to notice that he, with his felicitous style has been able to take the time to articulate, to assemble in a single text not simply what is involved at the heart of what my discourse has stated – and there is no doubt that this discourse is at the heart of his books since it is admitted there as such and that the seminar on the purloined letter forms in a way the opening step of it, defines its threshold – but in any case he, he was able to have the time for all these things that have nourished my discourse, have aided it, have occasionally given it its apparatus, such as the logic of the Stoics, for example. He allows himself, he is able to show its place as essential support, he is able to do so with this supreme elegance of which he has the secret. Namely, he takes advantage of the works of all those who have clarified this difficult point of Stoic doctrine, difficult because moreover it is only left to us in scattered pieces, outside testimony, with which we are forced to reconstitute, in a way by tiresome illuminations, what (175) effectively was its relief, the relief of a thinking that was not simply a philosophy but a practice, an ethics, a way of conducting oneself in the order of things.

It is moreover why for example the fact of finding on a particular page, page 289, something, the only point on which, in this book where I am evoked on several occasions, he indicates that he separates himself from a doctrine that is supposed to be mine, at least, he says, if a certain report that at a turning moment of my teaching brought before the assembled psychiatric community the essential of my doctrine on the unconscious, that of the two excellent workers that Laplanche and Leclaire were. How on this point, to keep to it, he says, he makes this

reservation. But he does not hesitate, of course, given the great relevance that on the whole this report has, to ascribe to me also something that seems to imply, namely, what he calls, what he translates as the plurivocity of signifying elements at the level of the unconscious. Or more exactly what is expressed in a particular formula that in re-reading this report, because I had my attention drawn to it by this remark of Deleuze, the possibility of any sense, it is written there, is produced from this veritable identity of the signifier and the signified that results, as perhaps some of you may remember, from a certain way of manipulating the metaphorical function, a little bit beyond the way I had done it. And to make the S, rejected below the limit, the bar, by the metaphorical effect of a substitution, function, to bring into play this S joined to itself as representing the essence of the relation in question and operating as such at the level of the unconscious. Undoubtedly, this is a point that I would leave all the more willingly to the authors who represented me in this remarkable report, represented me, because it is in effect what results from a certain manipulation by them of what I had stated up to then.

If anyone was willing to spend some time here going into the detail, that assuredly the excessive duties of my progress which is destined of its nature not to be able to stop at, given that it must still be a long one. If someone were able, in bringing together what Deleuze states in the whole of this work about what is here advanced absolutely not without relevance but undoubtedly in a way that represents a flaw, to establish why it is a flaw, to circumscribe in a more precise fashion what is faulty there, and what makes that fault very precisely consistent with what in this report plays around what I insisted on on several occasions the previous years, namely, what is essential in a correct translation, which comes back to saying in a correct articulation, of the function described as *Vortellungsrepräsentanz* and of its effective incidence with respect to the unconscious. If someone were willing to propose himself to clarify this which would have the advantage, as is always (176) necessary, to allow, and on this occasion in a public way, those

who refer to my teaching - and who, of course, complete it, nourish it, accompany it - from what was able to be stated in a way that they complete and sometimes in a clarifying way, the works of my pupils. To allow there, all the same, to be clarified what in one or other place of this work does not entirely express not, I would say, what was at that moment the axis of what I was stating but what subsequently was demonstrated to be its true axis. While waiting for someone of good will to put himself forward, I underline that the article that I am alluding to *The unconscious, a psychoanalytic study* was published, moreover I do not know why, in *Les Temps Modernes* in July 1961, namely, a considerable time after this report had been given at a congress described as that of Bonneval, the one to which there refers what I contributed myself in something edited that itself was much later, in my *Ecrits*, under the title of *Position of the unconscious*.

I am returning now to our agenda and I pursue my remarks of the last time and along the axis of what I announced to you as being on the agenda today, which is sublimation. The last time, I highlighted and stressed two things: that what was at stake, from Freud's point of view - there are of course many other passages to be quoted but this one is capital, it is in the *Introduction to narcissism* - first of all of the relation of idealisation *am Objekt*, to the object, and on the other hand the fact that sublimation is essentially attached to the fate, to the avatar, to the *Schicksal* of drives. It is one of those avatars, the ones stated by Freud in the article entitled *Trieb und Tribschicksal*, drives and their avatars. It is the fourth of them, and this fourth is characterised by the fact that it is constructed *mit dem Trieb*, with the drive. This term "with" that it is striking to rediscover here from Freud's pen, at least for those who have heard me in the past hammering out this "with" on several occasions. And particularly in taking up the formula of Aristotle: "it must not be said that the soul thinks but that man thinks with his soul". Something is satisfied with the drive. What is it when on the other hand Freud tells us that this drive that he dismantles for us, from these four dismantled terms - it is the formula that I have always underlined

as essential to the drive, it is a *montage* of these four terms: the source, *Quelle*, the *Drang*, the pressure, the *Objekt*, the object, and the goal (*but*), *Ziel* – the drive will find itself satisfying what? This is today what is in question, very precisely because of the fact that it is inhibited as regards the goal, that it elides what is involved in the sexual goal.

It is not enough all the same to translate this into what is undoubtedly the usual thing by thus imagining that it is at the expense of their sexual satisfaction that the authors, whoever they may be, whose works we appreciate, whose works take on a social value, because this is the term with which Freud himself accentuates the matter, that there is (177) here some obscure substitution or other. It is not enough to stay there to give its import to what Freud has stated. This indeed is why the premises, the time that I spent in tackling this subject by articulating explicitly in our two last meetings that sexuality, with respect to what interests us from the psychoanalytic field, certainly constitutes a horizon, but that its essence is much further away again, as I said. Neither its knowledge nor its practice, I am speaking about that of sexuality, are for all that either illuminated or modified by it.

This is what I would like to bring your attention back to again at a time when, on the biological plane, things are certainly clarifying a little. Everything we discover at the level of regulatory structure sometimes take on a strange isomorphism with our statements about the functioning of language. It is assuredly more than prudent not to remain, with regard to sex, at these crude schemas. If you approach with a little attention the works of someone like François Jacob on what is called bacteriography and everything that a rigorous experimental technique allows to begin to be seen about what is involved in the operation of living material, it may enter your head that even before there is a question of sex, there is a lot of copulating in it! That is why perhaps it is not unrelated that at another end of the field, our one, that has certainly nothing to say on the subject of biology,

people also notice that it is a little more complicated than that to speak about sex. And that, for example, it would be well not to confuse what is involved in the relationship, this term being taken in its logical sense, of the relation that grounds the conjoined function of two sexes. This seems like that to be self evident, huh, that there should only be two! Why should there not be three or more? There is not the slightest allusion here to the frivolous uses that have been made of this term of the third sex, for example – a book that is particularly remarkable, I am saying in parenthesis, for the irresponsibility it bears witness to – biologically. Why in effect should there not be three of them? The fact that there are two constitutes certainly one of the fundamental bases of reality. In this regard it would be well to notice how far its logical incidences go. Because, by a curious return, every time we have to deal with the number two, behold, at least in our mental arithmetic, sex re-enters by the side door. This all the more easily because one knows nothing about sex. A little indication, like that, that there is an extra chromosome somewhere. It is rather curious moreover that one can never say in advance for a particular species on what side, male or female, this extra chromosome, this disconnected, asymmetrical chromosome is going to be found. So then people would do better to pay attention to the fact that to state something about the sexual relationship, has nothing to do with what is completely substituted for it, and especially in psychoanalysis. Namely, the phenomena of identification with a type described, on this occasion, as male or female.

(178) Having said that, despite appearances, what psychoanalysis demonstrates, is precisely that even this identification with a type is not so easy as that. On the whole, it is only with great awkwardness that people manage to state something about it. The masculine position or the feminine position, people say. Very quickly people slip, people talk about the homosexual position. The least of things, is to be even the slightest bit struck that every time that Freud wants to make a precise statement, he admits himself that it is altogether impossible to

rely on this opposition of male or female, and that it is that of active or passive that he substitutes. It would be interesting to pose the question of whether if any one whatsoever of the two terms masculinity, maleness or femaleness (*'malité' ou 'femellité'*) femininity is an acceptable qualification as a predicate. Can one say "all males", can this even be stated in a naïve manipulation of adjectives. Why should an Aristotelian proposition not be dressed up as follows: "Every male in creation", for example? It is a question that would involve the following: does all the non- males, mean the females? The abysses opened up by such a confident recourse to the principle of contradiction might perhaps also be taken in the other sense and make us question ourselves, as in the approach I earlier announced, about what recourse to the principle of contradiction may itself contain in terms of sexual implications.

Of course there are modes other than yes or no that come into play in these phantasies coming from the improbable approach of the sexual relationship. There is the polarity, for example, of the sexual couple. This in the name of a more microscopic view of these filaments that are produced at the moment that, when the fecundating of the egg has taken place, something is established like a field between the two nuclei, a field that should be conceived of less as a kind of field of gradation than as a field involving, according as one approaches the two poles, an increasing and decreasing bivectoriality. Is the fact that it is supported in this way by this image of the field so fundamental in other domains, that of electromagnetics, for example, sufficient to allow us to think that sex and its fundamental relationship, is of that order, two poles, something that is organised, a texture of a spherical order between the two? Naturally, if one begins to ask oneself the question, one sees that the foundations are perhaps not so obvious as that. If we have forms that favour such a support, there are many other questions that may be raised, effects of dominance, influence, repulsion, indeed of rupture that are perhaps indeed of a nature to encourage us to put in question again what, I am saying, is only

possible to put in question of course starting from the moment that people perceived the degree to which what controls it is not discussed, is naïve as they say.

In any case, it is very necessary, when people speak about (179) *Fortpflanzung* for example, of what is going to be made, speaking about the finality of sex, namely reproduction, to see that it is not simply at the level of, when two people sleep together, from time to time a little baby arrives, that this is what gives the image of what is involved in sex. If I began by starting from the effects of sexual copulation at the cellular level, it is quite obviously to indicate that what is at stake is less the third that is produced than the reactivation in sexual union of a fundamental production which is that of the cellular form itself that, stimulated by this passage, becomes capable of reproducing something that is at its very heart, namely, its arrangement. Let us pay attention therefore to these contaminations which make it so easy for us to cover over a function the whole essential of which escapes us perhaps, with the position of plus or minus in mathematics, indeed that of the one or zero in logic. And this all the more because, as I might say, Freudian logic puts us precisely at the sharp end of the fact that it cannot function in polar terms. Everything that it has introduced as a logic of sex comes under the jurisdiction of a single term which is truly its original term, namely, the connotation of a lack, an essential minus that is called castration. Without this, nothing would be able to function at its level in so far as its level is of a logical order. All normativity is organised for the man as for the woman around the transfer (*passation*) of a lack. This is what we see at the level of the logical structuring such as it flows from Freudian experience.

I ought to recall here what I developed at length in a year that I evoked at one of our last encounters under the title of the *Ethics of psychoanalysis*. It articulates that the very dialectic of pleasure, namely, what it involved in terms of a level of stimulation that is at

once sought and avoided, a correct level of a threshold, implies the centrality of a forbidden zone, let us say, because the pleasure would be too intense. This centrality is what I designate as the field of enjoyment, enjoyment itself being defined as everything relating to the distribution of pleasure in the body. This distribution, its inner limit, is what conditions what at that time and of course with more words, more illustrations than I can give here, what I put forward, I designated as a vacuole, as this prohibition at the centre that constitutes, in short, what is nearest to us, while at the same time being outside us. It would be necessary to make up the word “extimate, *extime*” to designate what is at stake. At that time, I drew out of Freud’s texts – I do not have time to expand on which ones – the putting into operation from his pen of this term that I picked out, all the more striking in that it is distinguished from everything that he may have been able to say about things. Things are always *Sachen* for him. Here, he says *das Ding*. I am not going to take up again here, because again I do not have the time, the stress I put on this *das Ding*. All that I can say or recall is (180) that Freud introduces it through the function of the *Nebenmensch*, this man who is closest, this man who is ambiguous because one does not know how to situate him. Who then is he, this neighbour who resonates in the evangelical texts in the name of the formula “love your neighbour as yourself”. Where can he be grasped? Where is there, outside this centre of myself that I cannot love, something that is more neighbour to me? This moreover is what Freud, at the moment when, forced in a way by its necessity along deductive paths, cannot characterise it otherwise than by something absolutely primary that he calls the scream. It is in this ejaculatory exteriority that this something is identified, through which what is most intimate to me is precisely what I am constrained to recognise only outside. This indeed is why this scream does not need to be emitted to be a scream. I demonstrated in this magnificent engraving called *The scream*, by Munch, that nothing is more appropriate to its value as expression than the fact that it is situated in this calm landscape, with, not far down the road, two people taking their distance

and not even turning back. It is of the essence that from the twisted mouth of the feminine individual that represents this scream in the foreground, nothing should emerge but absolute silence. It is from the silence that this scream centres that there emerges the presence of the closest being, of the being all the more awaited in that he is always already there, the neighbour, who has no *Erscheinung* except in the acts of the saints.

This neighbour, is it what I have called the Other, what I make use of to make function the presence of signifying articulation in the unconscious? Certainly not. The neighbour, is the intolerable imminence of enjoyment. The Other is only its cleared out terreplein. I can, all the same, say these things rapidly, like that, given how long I have articulated for you the definition of the Other. It is precisely that, it is a terrain cleared of enjoyment. It is at the level of the Other that those who take the trouble will be able to situate what, in the book by Deleuze, is entitled with an admirable rigour and correctness, and as distinct, in agreement with everything that the modern thinking of logicians allows to be defined from what are called events, the production (*mise en scène*), and the whole carrousel linked to the existence of language. It is there, in the Other, that there is the unconscious structured like a language.

The question for the moment is not that of knowing how and by whom this clearing out was able to be made. We must begin first of all by recognising it. Perhaps afterwards we will be able to say sensible things. Only it is very important to define it like this because it is only starting from there that one can even conceive of what is perfectly well expressed in Freud, what I expressed in two terms that I think it is important to emphasise. On the one hand the formalisation, on the other hand the impassability, of what? Of desire. Because this is what Freud expresses, it is the last sentence of the *Traumdeutung*, the desire that is at stake, unconscious desire, maintains itself in its stability in an (181) impassable way, transmitting the requirements of what Freud

calls, rightly or wrongly, the past. It is not because there is *Vergänglichkeit* that this ought right away to make us drift towards thoughts of good or bad impressions, of the traumatic neurosis of the little child that still persists in each one of us, and other commonplaces that, of course, are not unusable. But what is essential, is this permanence, this constancy, and by the fact itself, what is meant by this impassability of desire that can therefore be completely reduced to the formal. So then, at what level is the sexual relationship situated as regards what we can formulate about it? This is the sense of the question as it is written on the first lines on the board: the Woman, the Other, the locus of desire that slides intact, impassable under every word or indeed the Thing, the locus of enjoyment?

So then, of course, this indeed is the moment to remind you that if there is a point where what I said to you - there is no sexual relationship - is affirmed, quite calmly in analysis, it is that one does not know what a woman is. Unknown in the box, except, thank God, through representations, because of course from all time she has never been known except like that. If psychoanalysis highlights something precisely, it is that it is by one or several representatives of representation, this is indeed a case of highlighting the function of this term that Freud introduces in connection with repression. It is not a matter of knowing at the moment whether women are repressed, it is a matter of knowing whether the Woman as such is, and of course moreover, and why not in herself, of course. This discourse is not androcentric. If the Woman in her essence is something, and we know nothing about it, she is just as repressed by women as by men, and she is doubly so. First of all by the fact that the representative of her representation is lost, we do not know what the woman is. And then that the representative, if it is recuperated, is the object of a *Verneinung* because what else can be attributed to her as a characteristic except that of not having what precisely there was never any question of her having. Nevertheless, it is only from this angle that, in Freudian logic, the woman appears: an inadequate representative, alongside the phallus

and then the negation that she has it. Namely, the reaffirmation of the solidarity with this thing that is perhaps indeed her representative but that has no relationship with her. So then, this ought to give us just by itself a little lesson in logic and see that what is lacking to the whole of this logic, is precisely the sexual signifier. When you read Deleuze – there are perhaps some who will take the trouble – you will be initiated into things that the weekly frequentation of my discourses was apparently not enough to make familiar to you, otherwise I would have more productions of this style to read. The fact is that the essential, as is said somewhere, of structuralism, if this word has a sense – only since it has been given a sense at the level like that of a whole forum, I (182) do not see why I would take on the privilege of it – the essential is at the same time this blank, this lack in the signifying chain, with what results from it in terms of wandering objects in the signified chain. So then the wandering object, here, for example, is a pretty little bladder that has been blown up, a little balloon, with two painted eyes and a little moustache on it. You must not believe that this is the man. What is written is that this is the woman, because it is indeed like that that one sees this ungraspable woman going about everyday; this is even what allows us to have a certain sense of the relative with regard to the fact that it might not be like that.

In a less logical epoch, when we go back into pre-history, where perhaps there was not yet the Oedipus complex, there are made little statuettes of women that must all the same have been precious for them to be still discoverable – they must all the same have been stuck into corners – who had a shape like that (drawing on the board). Here there is no longer a little bladder, or eyes or moustache, here huge buttocks and good, that is how a prehistoric Venus is composed. I have not drawn it very well but it was to give you an impression. It was less ~~andromorphous~~. This does not at all mean what palaeontologists imagine, that does not at all mean that they were like that. The representative of the representation was different than it is for us. It was ~~not~~ one or two balloons. If you remember also the breasts of

Tiresias, "Fly away, birds of weakness...". The representative of the representation was undoubtedly like that. This proves to you that depending on the times, the representative of the representation can be different.

So then, on these premises, we can now advance a little as regards what is involved in sublimation and I told you enough earlier about how Freud articulated it in order not to have to repeat it, *Zielgehemmt*, idealisation of the object, and working with the drive. Freud takes a certain number of doors through which it can happen. The simplest are obviously the *Reaktionsbildung*. If we know where the barrier is, namely, on the side of enjoyment, it is quite clear that one can imagine it, classify it, which moreover does not clarify it, among the *Reaktionsbildung*, the formation of reactions at the approach of enjoyment. But this is still not enough to explain to us how it gets out of step. Now Freud indicates to us in a little note, a sentence at the end, that there are outside all the approaches that he defines as possible for sublimation, other quite simple ones. Simply he does not say what they are. Perhaps he had some trouble thinking them out, in function of the fact after all that if he gave us the elements that can be called intuitive or again much more improperly naïve in mathematical logic about what constitutes our logical material, this does not mean for all that that he himself quite realised that it lent itself to formalisation.

(183) One sublimates, he tells us, with the drives. On the other hand, what do we know? Where do these drives come from? From the horizon of sexuality. Not in the slightest way clarified up to the present because of the fact that they involve a sexual satisfaction. But what we are told, is that their enjoyment is linked to sexuality. It is not a bad thing at this level that we first began by positing that we know nothing about sexuality. On the contrary what we have articulated and what I have articulated, is that in the drive there intervenes what is called in topology an edge structure, that it is the only way of explaining some of its traits. Namely, that what functions is essentially

something always roughly characterised by orifices and where there is found the edge-structure. Because only this edge-structure, taken in the mathematical sense, allows us to begin to comprehend what Freud articulated no less at the level of *Drang*, of pressure. Namely, the constancy of the flux that this edge conditions. I put in a note on this, I improved it again in the last edition, referring to what, in vector theory is defined as rotational flux.

The drive, in a word, just by itself, designates the conjunction of logic and corporeality. The enigma is rather the following: as edge enjoyment, how was it able to be called to the equivalence of sexual enjoyment? If you have all the same a little imagination, I mean the possibility of linking up what you cogitate somewhere in your convolutions with your experience that is certainly obviously accessory and always between two doors, you might all the same say, at the level of sexual enjoyment, it is rather a matter of tumescence for example, and then of orgasm, what does that have to do with the functions of the edge? If there were not the configuration of the vacuole, of the hole proper to enjoyment, to this something intolerable for what is essentially regulated as a tempered tension, you would see nothing in the sexual that is analogous to what I am calling in the drive an edge structure. Here the edge is constituted by a sort of logistics of defence. If one did not know after all that this logistics of defence is met at every turn, even in sexual practice, and precisely in the measure that this practice is something different to what is done in a rush, like that, with the vague little directive flotsam that remains to you from the Freudian vocabulary about the enjoyment of the woman, perhaps something might begin to interest you in a closer, more intimate, more direct way about what is involved, not in the sexual relationship about which you cannot say very much, but about what is involved in the handling of sexual enjoyment. All the enigmas that appear, we do not know why, when people study feminine sexuality, the enigma the sensitivity of the vaginal wall presents to the eyes of some people and makes it in a way I am not saying unsituateable but limitrophe to

(184) feminine enjoyment is something that will find itself much more easily in agreement with the topology that we are trying to approach here. But it is not our subject in its details. What is important is what I am putting forward, that something here resembles the Thing. And this indeed is why we give this Thing, that I made speak at one time under the title of the Freudian Thing, the features of a woman when, in the myth, we call it the Truth. Only it must not be forgotten – this is the sense of these lines on the board – that the Thing, for its part, is undoubtedly not sexed. This is probably what allows us to make love with her, without having the slightest idea of what the Woman is as a sexed thing.

So then that will perhaps allow us to introduce, given the time, the two directions from which sublimation can be studied. If I took care in my seminar on ethics to give a large place to courtly love, it is because this allowed us to introduce the fact that sublimation concerns the woman in the love relationship at the cost of constituting her at the level of the Thing. It is necessary, alas, because I am not going to redo all that ~~this~~ year, for you to refer – but I will try to make sure that you will have the text soon – to the long study I carried out at that time on courtly love to give its import to this. It is very enlightening, and it could be very advantageously re-read in the light of the formulae that I can finally now give in their absoluteness. The ritual of approach, the stages of gradus, as I might say, towards an enjoyment that is arranged, but moreover almost sacralised, is not one of the least amusing aspects of the affair, when one approaches and studies it. To see the awkwardness and I do not mean it is touching, it is simply repugnant, with which the people in these places where there is concentrated the run of the mill of these texts which, of course, no longer interest anyone. These people are irreducibly professors, namely, living in conditions that we all know when we go to visit them. Their major symbol I would say was very prettily given by Anatole France under the title of *Le mannequin d'osier*. I should also have made another drawing for you of the wicker mannequin, it would be in the opposite

direction. This kind of stupor, of bewilderment that lays hold of them, and then, my God, how these people, at that epoch, the dark night of the Middle Ages were so unrefined – can you imagine they were less refined than the professor in question and his little wife. How were these people able to imagine such exalted homage, what does all that mean, all these women that the poets sing to us about, they are all, all of the same characteristics. Obviously they all have the same characteristics, it is also a representative of representation, they are like the prehistoric Venus, they all have the same characteristics. That does (185) not mean that these women did not exist nor that the poet did not make love to them in function of their merits! There were many other things again that stupefied them, including the stress put on trials, cruelty, a thousand things of this kind. I had great fun for two and a half months, and I hope those who were listening to me at that time also had, I will try to clean this up in a way that it can be transmitted. In any case it is a homage, anyway this is what remains to us of it, restored by poetry to what is its principle, namely, sexual desire. The attempt, in other words, to go beyond what is involved, whatever is said about it in Freud's text, in accessible love, outside special techniques, namely, to remain always narrowly narcissistic.

Only there is the other aspect, the relationship of sublimation to what is called the work of art. When Freud tells us that sublimation gives the satisfaction of the drive and this in a production regarding which the characteristic of esteem that society gives it is quite unexplained. Why the devil, when we have so many concerns, if it is not indeed on the hypothesis of diversion. Namely, that it is precisely in order not to be occupied by worries that are much more important that we get a taste for some of the things that are poured out within reach of our purses in the form of novels, paintings, poetry and novellas. Taking the thing from this angle there appears to be no way out. Nevertheless, I will give you, as regards what I will introduce the next time, too rapid a way in. The relationship of sublimation to enjoyment, since this is what is in question, in so far as it is sexual enjoyment, can only be

explained by literally what I will call the anatomy of the vacuole. That is why I made on the right the outline of this something circumscribed that represents the vacuole. Imagine for a moment this vacuole as being the auditory apparatus of one these little animals that are called, I do not know why, primitive – nothing is more primitive than anything else – but take a daphne [?], it is like a tiny shrimp, but much simpler, it is found in waterways. The daphne, in something or other that one can say serves it as an auditory organ but at the same time as a vestibule, namely equilibrating, has what is called an otolith. If I know all that, it is because I have looked at the reviews....it is an article by a psychoanalyst, I will tell you who the next time, that drew my attention to it. It becomes very amusing, if, in place of the otolith you put a little piece of iron and afterwards you play around with magnets. This gives him enjoyment! Naturally one can presume it from the extraordinarily different attitude it takes up. Altogether a man in its moral life!

This is what I want to indicate to you as an introduction to the next time. It is that the *o-object* plays this role with respect to the vacuole. In other words it is what tickles *das Ding* from the inside. There you are. This is what constitutes the essential merit of everything that is (186) called a work of art. Nevertheless the thing deserves to be detailed. And since the *o-object* has more than one form as Freud explicitly states in saying in his analysis of the drive that the object can be very variable, it waltzes around, nevertheless we have managed to state four of them, between the oral object, the anal object, the scopophilic object and the sadomasochistic object. What is that one? Let us say that in connection with this one I am reserving some surprises for you the next time.

Seminar 15: Wednesday 19 March 1969

I am laying my cards on the table, I am not going to give my seminar – you can call it what you like: my seminar, my lecture, in any case, my thing...I will start again. It is not for nothing that you did not hear me at first. I am not inclined to speak loudly, because I am not inclined to speak at all. And besides that is what I am going to do, or, more exactly, not do. My intention is not to speak to you today. There is a certain relief in that. Because it may be that I have had enough! But in any case, precisely, there is not much relief in it because, as you see, I am rather tired. Imagine whatever you like, a little Hong-Kong, like that, during the weekend, because naturally a psychoanalyst cannot allow himself to be sick except at the weekend. Anyway, the result is there, I will not speak to you today. Moreover this is what I had resolved, to say to you: “Listen, there you are, I am reporting sick; the seminar, as you call it, will not take place today”, and then clear off.

It would be too simple. I already announced the last time the pleasure that it would give me to be able to hear something that might come to me as a response, a certain testimony that might come to me of what you are making of what is happening to you in terms of what I am trying to outline this year. It is obvious that many things push me to want it. First of all, a certain feeling, at the limit, of what I might be doing in pursuing here could be, what is pinpointed, it is hard to know why, in fact, as teaching. Does it really fit into the framework of teaching, apart from the fact that it takes place within the perimeter of

the Ecole Normale? It is not certain. And then, my God, it has to be said today, why are there so many people? It truly is a problem. But it must be all the same that there is something interesting in it, like that. I have no reason to believe that it will be long lasting, at the rate things are going, I mean this interest taken in what is happening here.

I happened this week, which was necessarily not very stimulating - I rarely get a temperature of 39°, I spent a certain time, I spent two days telling myself that it is surely because there must be something like that not very stimulating in this state that I am still in - to ask myself what is happening here. So then I made a working hypothesis, make no mistake, that what I was doing here whether you know it or not, has (188) really all the nature of a work. This is what perhaps may allow you to glimpse certain things that I said this year. But in any case it is certain. The way I usually talk to you, when I have my little notes, that may astonish you, I more or less look at them; there are a lot of them, there are surely too many, it has really all the characteristics of what happens on a work bench, and why not? Indeed on an assembly line. The papers come from somewhere and will end up also by being transmitted to others. And with that, in effect, something happens as regards which, when I go out, I am always rather perplexed to question, with sometimes a little anxiety, those whom I know are able to say something that interests me. It is certain that I did on this something that has really the character of a work that has been produced with a certain material and which is something constructed, realised, a production.

Obviously, it is interesting; it is interesting to see it being done. It is not all that widespread to have the opportunity of seeing someone doing his work. For most of you in any case, I have the feeling that what this work is aimed at, what it is destined for, cannot but completely escape them. This is still more interesting. Only this gives to the thing, the fact of looking at someone working without knowing where it is going, of what use it is, this gives a rather obscene

dimension to the thing. Naturally, it is not true for everyone. There are those who know well of what use it is. Anyway, what use it is in the short term. Since I am in the process of pushing this working metaphor, I would say that my bosses, for their part, know what use it is. Or, inversely, if you wish, those who know what use it is are my bosses. There are some here who are part of them. It is for them that I work. And then there are some others who are between the two classes and who, for their part also, have an idea of what use it is. These are the ones who, in a way, insert the work that I am doing here into a different text, or into a different context, which is that of something that is happening, for the moment, at what one can call the level of the University. I am very interested in it. I mean that there is something in what is happening anew in the University that has the closest relationship with the work that I am doing.

Because of this temperature and this pause that it gave me, anyway, you cannot imagine how happy one can be in taking advantage of having a temperature of 39°, I mean one is necessarily, one can usually put oneself in a horizontal position; it is very agreeable. Finally, when it subsides a little, at a certain turning point, one can open things, entertaining journals. There is one, as you know, the one managed by someone called Jean Daniel called *Le Nouvel Observateur*. It is no doubt called that in order to make you believe that there is something new in what is observed. You would be wrong to expect it, and the proof is that what I was able to read in it like that, horizontally, is the (189) sort of thing that, if I remember rightly, is something that is called "*The young ensnared, La jeunesse piégée*". I do not know why, it is perhaps due to my 39°, but this absolutely enraged me. First of all the title. Let every person that uses the word *piégé* know that the use of this word is considered to be repugnant – this is my own idea – a way of crudely stirring up castration anxiety, especially when one is talking to the young, and for the moment that seems to me to be in very bad taste. And then, faith, there is nothing in it but things that are very astute, very relevant. There is perhaps not a single one that, taking it

as a sentence, as an indication of the justification, legitimising of whatever you want, not a sentence against which I could obviously, seriously raise any opposition. All of that is very good. It is very boring because it leaves completely to one side what is at stake. Because of course, I am not against any of the forms, even the most extreme ones, of what associates, for the moment, the contestation, as the student contestation is described, with the most revolutionary unions. But I think that none of this goes beyond the axis of something that has happened as a consequence of certain facts, of certain facts which are the following. "The university was inadequate in fulfilling its function and, all of a sudden, it had got to such a point, to such an excess, people believe, that was why 'May' happened." It is a very serious point as regards the interpretation of the thing. It was inadequate with regard to a certain traditional function, a certain glorious time that it had enjoyed and which had responded to the use at different epochs, of different functions, that had different incidences, precisely according to the epochs, about the transmission of knowledge.

If we place ourselves from the point of view of quality, lustre, historical influence, it is certain that for some time this had taken a turn that was not particularly brilliant, but in any case, there were islands that still held up very well. If it proved to be inadequate at a certain level, it is that because of certain social requirements it was no longer up to the task. The question should be posed if the fact that it was no longer up to the task – not of all, but of certain tasks – it was not, when all is said and done, intentional. I mean that, if, taking things from the angle of power, it was not something that was regulated precisely in a way not to embarrass it too much. It is certain that a certain evolution, which is that of science, risks posing altogether new and unexpected problems to the functions of power. After all, the thing had been announced perhaps for some time. This is how it is perhaps and, it must be said, it would really have a retroactive sense effect to notice that it is perhaps in function of this that the word revolution has taken a

different sense, a different accent from the one it always had in history, where revolutions, by definition, were not new. From all time powers only came to an end by revolutions. The Revolution, like that, with a (190) capital R, did not notice soon enough that it is linked to something new which is highlighted from the side of a certain function of knowledge, something that is happening, which in truth renders it difficult to handle in the traditional way.

In order to indicate a little bit what I mean by that, I will bring it back to this something that I indicated earlier, namely, the fascination that can be produced about a work whose meaning people do not know, nor where it is leading. As a way of exemplifying, taken in the model given by what might motivate, in this supposition, your presence here, because obviously, from a certain angle, the reference that I found in the worker-boss relationship also has its prolongation here. The boss knows what the worker is doing, in the sense that he is going to bring him profits, but it is not sure that he has a clearer idea than the worker about the sense of what he is doing.

When you are dealing with the assembly line in Fiat or elsewhere, I am talking about that of Fiat because I already evoked it, here or elsewhere. I was there. I really had this feeling, in effect, of seeing people occupied with work and my absolutely not knowing what they were doing. That made me feel ashamed. It does not make you so, so much the better. But in any case, I was very embarrassed. I was precisely with the boss, Johnny, as he is called, as I call him. Johnny was also obviously...in any case, he too was ashamed. That expressed itself afterwards by the questions he asked me, which all had the obvious aim designed to dissimulate his embarrassment, the obvious aim of telling me that, to all appearances, they were happier there, with him, than in Renault.

I did not take this question seriously and I only interpreted it as you see, as a displacement, or perhaps as a way of avoiding on my part the

question: "Finally, of what use is all of this?" Not that I am say that capitalism is of no use. No. Capitalism is precisely of use for something and we ought not to forget it. It is the things that it makes that are of no use. But that is a completely different affair. This is precisely its problem. In any case, what it is supported by, and it is a great force, ought to be clarified. It operates in the same sense as the one that I was telling you about earlier, it goes against power. It is of a different nature. And it causes great embarrassment to power. There also, it is obviously *nachträglich*, it is subsequently that we have to see the sense of what is happening. Capitalism completely changed the habits of power. They have perhaps become more excessive, but in any case they have changed. Capitalism introduced something that had never been seen before, what is called liberal power.

There are very simple things about which, after all, I can only speak from very personal experience. Observe that as far as historians can remember we have never heard tell of an organ of government that one leaves by handing in one's resignation. Where authentic, serious, subsistent powers exist you do not hand in your resignation, because it (191) has very serious consequences. Either it is a simple way of expressing oneself, you hand in your resignation, but you are shot on the way out. I call those places where power is serious. The idea of considering as a progress, and again as a liberal one, institutions where, when someone has completely bungled everything that he had to do for three months or six months and has proved to be incompetent, he has only to hand in his resignation and nothing will happen to him. On the contrary, he is told that he will have a wait before he comes back the next time; that all the same means what? That had never been seen in Rome! In places where it was serious! You have never seen a consul hand in his resignation, nor a tribune of the people! It is properly speaking unimaginable. That simply means that the power is elsewhere.

It is obvious – the whole nineteenth century illuminates it – that if things occur through this function of resignation, it is because power is in different hands. I am talking about positive power. The interest, the only one, of the communist revolution, I am speaking about the Russian Revolution, is to have restored the functions of power. Only we see that it is not easy to hold onto, precisely because in the time when capitalism reigns, capitalism reigns because it is closely connected with this rise in the function of science. Only even this power, this camouflaged power, this secret and, it must also be said anarchic power, I mean divided against itself, and this without any doubt through its being clothed with this rise of science, it is as embarrassed as a fish on a bicycle now. Because all the same something is happening in the science quarter, something that transcends its capacity for mastery. So then what is necessary is that there at least a certain number of little heads that do not forget the fact that a certain permanent association of contestation with initiatives that are not controlled in the sense of revolution is vain. Well then, this again is what in the system, the capitalist system, can best serve it.

I am not in the process of telling you that things must be reformed. The reform itself, an incontestable consequence of the agitation in May, is exactly of a nature to aggravate its effects. If you have inadequate teachers, you will be given them by the shovel load, and you can be sure ones that are even more inadequate! Through reform the effects will always get worse. The question is what to do with regard to this phenomenon. It is certain that it cannot be responded to by a slogan, but that a process which tends towards the elimination of the best, in the long run, by the path of contestation, which is imposed, in effect, on the best people, will have exactly the wished for effect. This will be to bar for the very best people the interesting route, this joint, this access to a turning point, to a sensitive point, to a full stop put at present, concerning the function of knowledge in its most subversive mode. Because it is obviously not at the level of agitation (192) and hue and cry that there can be refined, treated, produced

something that can give a decisive turn to things. I am not saying what, and for the best of reasons, it is precisely because one cannot say it. But it is only there that there can be presented something new, the only new thing in whose name there can appear what grounds the putting in question of what is presented up to now as this or that, as philosophy. Namely, any function tending to put order, a universal order, a unitary order, this mode of relationship to oneself that is called knowledge.

This trap (*piège*), that consists in refusing and doing nothing more is, properly speaking, for the moment, for everything that exists, for everything that subsists, most disadvantageous. The assured promise of subsisting and in the most unfortunate way, for anyone who creates illusions about what is called progress, I intend to posit the fact, I can only – to come back to this something, like that, which served as an occasion for it – find in it a further sign, in the fact that the entourage of the one under whose name – since it is an interview that allowed this article under the title of “*Jeunesse piégée*” – and that since this is how things are, all I can do, at this level, is to bestow on him the title of what, in this connection, has always been my thinking, namely, that after all, his thinking does not go any further, objectively, than that of an entertainer. This is serious enough. It is the testimony, after all, of a man who has lived long enough to testify, in a way, to two between-the-wars. The one between the two previous ones, that I lived with Giraudoux, Picasso, and other surrealists and it wasn't only Giraudoux that was original in all of that, this to tell you that I did not amuse myself a lot. Picasso existed from long before. Whatever you may think about them, these surrealists were a re-edition. Everything that constituted their core had existed before 1914, everything that projected something irreducibly unsatisfying in their presence between 1918 and 1939. You will note that I was their friend and that I never signed the least thing with them. This did not prevent a little scoundrel, named Laurin, who was a Canadian, from noticing it and making of it – I do not know...like that to initiate the public of

Saskatchewan – about what I might be, in order to make a big deal of this surrealist root. There was also Parcheminey, a very special personage of the top drawer, with whom I was associated and made a lot of that. I explicitly told him that he should not take it into account, because I myself had taken care not to mark my link to any degree. This did not prevent him from writing “Lacan and the surrealists” ... You cannot be too accurate in feeding error.

And then, since the new between-the-wars, a failed between-two-wars because there is no end to it, this indeed is what embarrasses them, it is the expiry date. The fact is that capitalist power, this singular power whose novelty I would ask you to measure, needs a war every twenty (193) years. I am not the one who invented that; others have said it before me. This time, it cannot achieve it, but in any case it will manage all the same. It cannot arrange one and meanwhile it is very bothered. Finally, in this between-two-wars there was Sartre. He was no more amusing than the others. That did not disturb me. I never said anything about it, but anyway is it not curious that someone should feel the need to encourage so many of these young people to throw themselves against these obstacles that are placed before them, like that, to go to war, in short, a very mediocre war. Is it not beautiful to be able to go up against these muscle bound apparitors, because I approve of this thing called courage. Courage, physical courage is not a very great merit. I have never noticed that it caused a problem. I do not think that it is at that level that it is decisive. And above all it is of no interest. On some occasions, to throw oneself against the obstacles that are presented to you, is to behave exactly like the bull, is it not. What should be at stake precisely is to go somewhere other than where the obstacles are; in any case, not to be particularly interested in obstacles.

There is, in all of that, a veritable tradition of aberration. People begin by saying that philosophies for example throughout the centuries were only ideologies, namely, the reflection of the superstructure, of the

dominant classes. So then the question is settled. They are of no interest. You have to aim elsewhere. Not at all! People continue to fight against ideologies *qua* ideologies. They are there for that. It is completely true that there have always been, naturally, dominating or enjoying classes, or the two, and that they had their philosophers. They were there to be abused in their place. That is what is done, namely, people follow orders. In fact, it is not at all correct, is that not so, it is not at all correct! Kant is not the representative of the dominant class of his epoch. Kant is still not only perfectly acceptable but you would do well to follow his line were it only to try to understand a little bit what I am in the process of telling you about the *o*-object. Anyway we will come back to that. Yes.

The last time I spoke to you about sublimation. So then obviously, we must not all the same remain there with it. It is not by chance, all the same, that it is at this point that there is a little suspension, or a little suspense, as you wish. Try to describe the relationships of this co-presence seen from your side? From mine? The question can be asked. Let us put it on the side of sublimation. It would be better, in any case, to put it there today, because that puts you in the position of the feminine pole. There is nothing dishonourable about that, especially at the level at which I placed it, the highest elevation of the object.

There are things that I did not underline the last time, but in any case I hope that you have good ears. The idea that sublimation is this effort (194) to allow love to be realised with the woman, and not simply... to pretend that it is happening with a woman. I did not underline that in this institution of courtly love, in principle, the woman does not love. Or at least one does not know anything about it. Can you imagine what a relief it is? Moreover, it all the same happens sometimes, in novels, it happens that she becomes inflamed. You also see what subsequently happens. At least, in these novels you know where you are going. In any case, in a sublimation like the one that can be

realised here, I am saying that because it is about time to say it before we tackle another phase of sublimation that I began the last time, the one that is at the level of the drive and which, alas, concerns us much more, to which I gave the first prototype in the shape of the function of the bell (*grelot*). Something round with a little thing, the little o-object, which is strongly shaken inside. Let us use then, before this comes on the scene, more agreeable forms.

At the level, then, of man-woman relationships, if from the side of my audience I do not have to fear that any madness will occur, nevertheless if someone now wished all the same to bring me a sign of having heard by posing a question, either about what I have just said, or, which I would prefer, about what I have been saying since the beginning of the year. I would like a question or two to be directed to me, on this agreeable terrain for which, you see, I myself make a courteous effort not to disappoint, even on a day that I am at the end of my tether.

Who is there who can pose a few questions?

Do not discourage me too much. Because, after all, I could for my part be also tempted to resign...suppose for example that those whom I called my bosses, namely, the people for whom I work, do not threaten, once my work has consequences that interest them, do not threaten for their part their resignation. That may happen one day. Well then! I will be content to do my work before them. You are not there, all of you, all of you who are not, in short, psychoanalysts in my eyes, anyway from my point of view, my principal use is to give them the feeling indeed that they cannot, for their part, hinder me in continuing to do my work. Even if nobody answers me, from this field of non-psychoanalysts, I see very interesting faces down there. All the same I know my people.

If none of those who are not psychoanalysts ever give me a response, not really a response that amuses me a little, suppose that one day I managed all the same to undo the psychoanalysts, by showing them that it would be just as interesting for them to work because they think that it is the privilege of the psychoanalyst. What is absolutely exaggerated in my way of working for them, is that I am doing, in short, what the psychoanalyst does. They have put the work (195) definitively into the hands of the psychoanalyst. They reserve the listening for themselves. There is among them, according to the latest news, one who summons them by saying "come and listen to me listen. I invite you to listen to my listening."

Now, perhaps, I am going to manage to shake up something on the side of this strange terrain, closely linked in its crucial points, about what is involved in this subversion of the function of knowledge. But I will not give an open seminar. I find that is not very serious. In a way, I question myself before the word of "handling knowledge" because this word "handling, *manier*" begins to take on a disturbing extension. There is a person, a marvellous chap moreover, who came to find me, who will do very well. Naturally, in the first meeting with me things happen. He came back the second time because you have to see someone at least twice. He told me that the previous time he had "manipulated". I searched my brain...I made him explain it...that means that I had manipulated him. The slippage of words is always interesting to see. The word "manipulate", has become, now, in the permanent vocabulary, through a type of fascination that comes from the fact that people do not think that one can perform any effective action on any group whatsoever without "manipulating" it. This, like that, in a way that is henceforth admitted, recognised. And after all it is not sure that in effect, as they say, the worst is perhaps certain, but after all, that is what it is, yes. But then, that this takes on an active value when one is manipulated, this is a tipping over point that I am signalling for you. If it should spread, you will let me know if you see it continuing like that.

Anyway, this is obviously not the best of conditions in which to pursue questions concerning knowledge at the level at which they are presented, in the measure that psychoanalysis can bring something to it. The last time I highlighted the book of our dear Deleuze, about the *Logic of sense*. I asked Jacques Nassif, since in truth I am not astonished, I am as they say very embittered by the total absence of response after a provocation that has been pushed that far. It is not manipulation, precisely. There are other ways of working. But this total silence, this total absence of response to my desperate appeals for at least a little testimony! I will leave you a repeat examination. You can write to me. The written happens after the oral. Anyway, if one day, at the end of the year, I gave two or three sessions with closed doors, you should know that apart from the people that I already know, the people who have written to me will have the privilege of it.

Nassif, do you still feel you have the courage, after this exhausting session, at least for me, to take the floor? Well then! You are extremely kind.

(196 –203) Jacques Nassif on Gilles Deleuze

Seminar 16: Wednesday 26 March 1969

(205) Today I am going to put forward primary truths, since moreover it appears that it would be no harm to touch base again. On the other hand, it also seems very difficult to organise these complementary fields of work that would allow us to be in accord, to attune our violins with everything contemporary that is being produced and is profoundly interested by what a certain step in psychoanalysis can put forward at the point we are at.

At our second last meeting, I left things at the point where sublimation should be questioned in its relationship to the role played in it, in short, by the o-object. It is this remark that showed me that it was necessary, that it was certainly, in any case, no harm for me to come back to what distinguishes this function, and that I should come back to it at the level of the experience from which it has emerged, from psychoanalytic experience as it has been extended since Freud. On that occasion, I was led to return to the texts of Freud in so far as they progressively established what is called the second topography. This, assuredly, is an indispensable echelon for comprehending everything that I myself was able to put forward, I mean in terms of discoveries, at this precise point that Freud remained at in his research. I already put the accent on what this word means in my speech, *circare*: to turn around a central point, as long as something is not resolved. Today, I will try to mark the distance at which psychoanalysis remained up to my teaching, a key point that assuredly from all sides the experience preceding it had formulated, sketched out in certain assertions. It had not been absolutely purified,

resolved, completed, and we will say at least now that we can construct other steps, but that do not correct it, namely, this function of the o-object.

Because it interests us at the level of sublimation, it is indeed certainly, as with this sort of almost clumsy prudence with which Freud put it forward, the work of art, to call it by its name, that today centres, constitutes the aim of what we are stating about sublimation. The work of art is not presented otherwise at the level where Freud grasps it, obliges himself not to grasp it otherwise than as a commercial value. It is something that has a price, perhaps no doubt an exceptional price, but once it is put on the market, not all that distinguishable from any other price. What is to be emphasised, is that this price is something it receives from a privileged (206) relationship of value to what in my discourse I isolate and distinguish as enjoyment. Enjoyment being this term established only by its evacuation from the field of the Other and by that very fact by the position of the field of the Other as locus of the word as such.

What makes of the o-object something that can function as equivalent to enjoyment, is a topological structure. It is very precisely in the measure that simply by taking the function through which the subject is only grounded, is only introduced as an effect of the signifier and by referring ourselves to the schema that I repeated a hundred times before you since the beginning of the year of the signifier S as representative of the subject for a signifier that, of its nature, is other. This means that what represents it can only posit it as before this other. This necessitates the repetition of the relationship of this S to this O as locus of other signifiers, in a relationship that leaves intact the locus which is not to be taken as a part but - in conformity with everything that is stated about the function of the set, as leaving the element itself as a potential set - makes this residue, even though it is distinct under the function of the o, equal to the weight

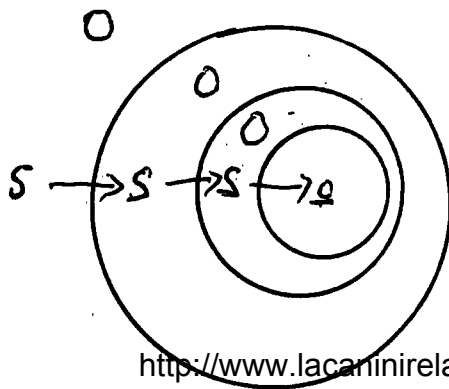

of the Other in its totality. It is in so far as it is here a place that we can designate by a term connecting the interior (*l'intime*) to radical exteriority, it is in so far as the o-object is extimate (*extime*) and purely in the relationship set up by the establishment of the subject as an effect of the signifier, as determining by itself in the field of the Other this structure in which it is easy for us to see the kinship, the variations in what is organised from any edge structure in so far as it has the choice, as one might say, to reunite itself in the form of a sphere, in so far as the edge thus drawn joins together at a most problematic point, even though apparently the most simple, of topological structures. Whether we pursue it in this shape, of what produces the torus, by joining the two opposite edges that correspond point by point in a double vectorial line, or on the contrary we have the structure – I am only here recalling it – of the cross cap, or that we have by combination of two different possibilities the structure described as the Klein bottle.

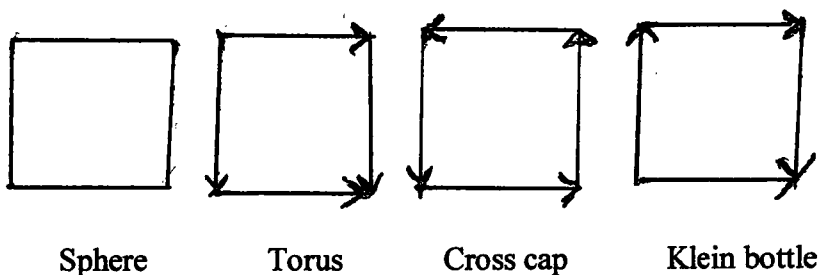

(207) Now it is easy to see that the o-objects as they effectively function in the relationships engendered between the subject to the Other in the real, reflect one by one, these four topological structures, there are also four of them. But this is something that, to indicate it immediately, I will only come back to later, and by first reanimating for you the concrete function, the function that the o-object plays in the clinic. The o-object before being possibly, through the methods developing its production in the form that earlier we have described as commercial is at levels precisely exemplified by the clinic, in a position to function as the locus of the capture of enjoyment.

And here I will make a jump, I will go quickly and straight away to a certain core of the subject which perhaps my first remarks, coming to you

here today, made a greater detour around. Very quickly, in theoretical statements, I am speaking about those of Freud, the relationship between neurosis and perversion was seen to emerge. How did that in a way force itself on the attention of Freud? Freud introduced himself into this field at the level of neurotic patients, subjects of all sorts of disturbances and who, through their stories, tended rather to lead him into the field of a traumatic experience as it appeared first of all to him, even though assuredly in the problem of what, in a way, welcomed this experience in the apparently traumatised subject, the question of the phantasy was introduced. This is indeed, in effect, the knot of everything that is at stake concerning an economy for which Freud produced the word libido. But again we should entirely trust the fact that these phantasies might allow us, in a way, to reclassify, to rearrange from outside, namely, from an experience that did not come from perverts, what at first in the same epoch – do I need to recall simply the names of Krafft-Ebing and of Havelock Ellis – presented in a descriptive fashion this field described as that of sexual perversion.

We know the difficulty that very quickly arose, after this first approach, already of a topological order because it was neurosis that was at stake, of finding in a way, because people spoke about the reverse side, something or other that already was presented as the announcement of these surfaces that interest us so much because they emerge when a cut slices them. But very quickly, the matter appeared to be in no way resolved, simplified in any way by being presented perhaps a little quickly as a function in stages, (208) neurosis assuredly, presenting itself with regard to perversion as at least repressing it on the one hand, as a defence against perversion. But is it not clear, was it not immediately so, that no resolution could be found by simply bringing out a perverse desire in the text of the neurosis? If this formed part of the spelling out, of the deciphering of this text, it nevertheless remains that in no case, is it on this plane that the neurotic finds his satisfaction in the treatment. So that in tackling perversion itself, it appeared very quickly that it presented with regard to structure no fewer problems and defences on occasion than neurosis. All of this fell under the jurisdiction of technical references whose impasses seem after all,

when one looks at them from a distance, to come only from a relative dupery undergone by the theory, from the very terrain to which, whether in the case of the neurotic or the pervert, it has to stick.

If we take things from the level that the return to this solid ground that nothing happens in analysis that ought not to be referred to the status of language and to the function of the word allowed us to articulate, we obtain what I did one particular year under the title of *The formations of the unconscious*. It is not for nothing that I started from what, in appearance, from what in these formations is most distant from what interests us in the clinic, namely, the witticism. It is starting from the witticism that I constructed this graph which moreover, even though it has not yet demonstrated to everyone how obvious it is, nonetheless remains fundamental on this occasion. As everyone knows and can see, it is made up of the network of three chains, two of which find themselves already marked, if not elucidated, by certain formulae some of which have been abundantly commented on. Since $\$ \diamond D$ marks as fundamental the dependence of the subject on what, under the name of demand, has been strongly distanced from need. The very signifying form, the defiles of the signifier, as I expressed myself, specifying it, distinguishing it and in no way allowing the its effect to be reduced to the simple terms of physiological appetite. This of course is required but illuminated by this medium, is required from the simple fact that in our experience these needs only interest us in so far as they take up the position of being equivalent to a sexual demand. The other junctions, signified as coming (209) from O as the treasury of signifiers, only constitute, at the point that we are at, a simple reminder.

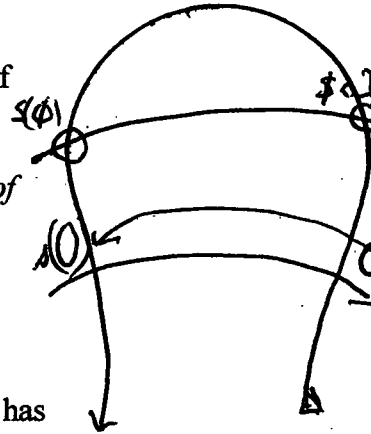

What I want to advance here, since moreover I never saw it distinguished by anyone, is that, even though what is at stake in these three chains are chains that can only be superimposed, established, fixed in so far as there is something of the signifier in the world, that discourse exists, that a certain type of being is caught up in it who is called man, or the speaking

being, that here, starting from the existence of the possible concatenation as constituting the very essence of these signifiers, what we have there and what the complement of this graph demonstrates, is the following. If this symbolic function here of the possibility of return is operating, which is made up of the statement of the simplest discourse, of this fundamental one at the level of which we can affirm that there is no metalanguage, that nothing of all that is symbolic could be built up except from normal discourse. This we can specify from the category that I distinguish as the symbolic, and we notice that what is involved in the upper chain is very precisely its effects in the real. Moreover the subject, which is its first and major effect, only appears at the level of the second chain.

If there remains here something that assuredly, even though always discussed and particularly in my discourse of this year, did not take on, because this is the object starting from which I advance, its full agency, it is what is involved in the signifier as such through which there appears the fundamental incompleteness of what is produced when it is constituted as the locus of the Other, or more exactly what in this locus traces out the path of a certain altogether fundamental lure. The locus of the Other as evacuated of enjoyment is not simply a clear place, a burned circle, of what is not simply this Other, this place open to the interplay of roles, this something structured of itself from the signifying incidence, it is very precisely what introduces into it this lack, this bar, this gap, this hole that can be distinguished by the title of the o-object. Now this is what I intend to make you sense here by examples taken at the level of the experience to which Freud himself has recourse when it is a matter of articulating what is involved in the drive.

Is it not strange, after having put so much emphasis in experience on the oral drive, on the anal drive, so-called outlines, described as pre-genital, of something that is supposed to come to maturity by fulfilling some myth or other of completeness prefigured by the oral, some myth or other of gift, the giving of a present, prefigured by the anal, that Freud to all appearances, should articulate what, in these fundamental drives, is

involved in the *montage* of the source, of the pressure, of the object, of the end, of the *Ziel*, with the help of the scopophilic and sadomasochistic drives. What I would like to advance, just like that, is that the function of the pervert, the one he fulfils, far from being - as has long been said, as (210) people no longer dare to say for some time and principally because of what I have stated - founded on some contempt for the other or, as they say, of the partner, is to be measured in a much richer fashion. And that to allow it to be grasped, at least at the level of the heterogeneous audience that I have before me, I would articulate it by saying that the pervert is the one who devotes himself to filling this hole in the Other. That, up to a certain point, to give here the colours that give their relief to things, I would say that he is in favour of the Other existing, that he is a defender of the faith.

Moreover, in looking more closely at the observations, in this light that makes of the pervert a singular auxiliary of God, one will see there being clarified the bizarre things that are advanced from pens that I would describe as innocent. In a treatise of psychiatry very well done, faith, as regard the observations it collates, we can see that an exhibitionist does not manifest his frolics only in front of little girls. He may also do so in front of a tabernacle. It is certainly not simply by such details that something can be illuminated. But simply, first of all, by having been able to map out, which was done here already a long time ago, the function that can be isolated in everything that is involved in the field of vision, from the moment that these problems are posed in the work of art, what is involved in the function of the look. By definition, it is not easy to say what a look is. It is even a question that can very well sustain an existence and ravage it. I was able to see at one time a young woman for whom it was properly this question, joined to a structure that I do not have to indicate any further, that went as far as producing a retinal haemorrhage whose sequelae were lasting.

What prevents people from realising that before questioning oneself about what is involved in the effects of exhibitionism, namely, whether it

frightens or not the witness who appears to provoke it, namely, if it is indeed the intention of the exhibitionist to provoke this shame, this fright, this echo, this something coy or consenting, who does not see first of all that what is essential in this aspect that you can describe as you wish, active or passive, I leave you the choice, of this scopophilic drive – in appearance it is passive because it offers itself to be seen – is properly and above all to make the look appear in the field of the Other? And why, if not to evoke there this topological relationship of what is involved in the flight, in the ungraspable nature of the look in its relationship with the limit imposed on enjoyment by the function of the pleasure principle. It is the enjoyment of the Other that the exhibitionist watches over. It seems that here, what creates the mirage, the illusion, and gives, suggests this thinking that there is a contempt for the partner is the forgetting of the fact that beyond the particular support for the Other that this partner gives, there is this fundamental function which is nevertheless present there (211) every time the word functions, the one in which every partner is only included, namely, from the locus of the word, from the reference point where the word is posited as true.

It is in this field, the field of the Other *qua* deserted by enjoyment that the exhibitionistic act is posited to give rise there to the look. This is how one sees that it is not symmetrical to what is involved for the voyeur. Because what is important for the voyeur, and very often is the way in which everything that can be seen is in a way profaned at his level, is precisely to question in the Other what cannot be seen. The object of desire of the voyeur in the slender body, the profile of a little girl, is very precisely what can be seen there only by the fact that it supports [is supported by?] the ungraspable itself, a line where it is lacking, namely, the phallus. That the little boy sees himself sufficiently maltreated for nothing of what, for him, can be attached to this level of mystery, does not appear to hold the attention of an indifferent eye, to project all the more, this thing neglected in him, by restoring it in the Other, by supplementing the field of the Other with it, without even being aware of its support. Here, from this unawareness, the enjoyment for the Other, namely, the

very end of perversion finds itself in a way escaping. But it is moreover what demonstrates first of all that no drive is simply the return of the other. They are asymmetrical and what is essential in this function is a supplement, something that at the level of the Other questions what is lacking in the Other as such, and provides for it (*y pare*). This is why certain analyses, and always in effect the most innocent ones, are exemplary. It is impossible for me, after having, as I did the last time, thrown doubt on the lack of seriousness of a certain philosophy, not to remember the extraordinary relevance of what is grasped in the analysis of the function of the voyeur. The one who, when he is looking through the keyhole, who is truly what cannot be seen, nothing more assuredly can make him fall from a height than being surprised in his capture by this slit, as regards which it is not for nothing that a slit itself, is called a look, even a day. The return is what is at stake, namely, his reduction to the humiliated, indeed ridiculous position which is not at all linked to the fact that he is precisely beyond the slit, but that he can be grasped by another in a posture that only collapses from the point of view of the narcissism of the upright position, that of the one who sees nothing because he is so sure of himself. This is what, at a page that you will easily find in *Being and nothingness*, has something imperishable about it, whatever may be the partial aspect of what is deduced from it as regards the status of existence.

But the following step is of no less interest. What then is the o-object in the sadomasochistic drive? Does it not seem to you that highlighting the prohibition proper to enjoyment, ought also to allow us to put back in its (212) place what people believe to be the key of what is involved in sadomasochism, when they speak about playing with pain and immediately retract and say that after all, it is only amusing if the pain does not go too far. This sort of blindness, of lure, of false fright, of tickling the question reflecting in a way after all the level at which there remains everything that is practised in this kind of thing, does this not run the risk, is it not in fact the essential mask thanks to which there escapes what is involved in sadomasochistic perversion?

You will see later, if all of this does not appear too daring to you, indeed a speculation that is not favourable to an *Einführung*, and with good reason. For the majority of you, all of you such as you are, whatever you may believe, what is involved in perversion, in true perversion escapes you. It is not because you dream about perversion that you are perverse. Dreaming about perversion can be used for something completely different, and principally, when one is neurotic, to sustain desire, which one really has need of when one is neurotic! But this does not at all allow you to believe that you understand perverts. It is enough to have worked with an exhibitionist to see that one understands nothing about what in appearance I will not say makes him enjoy himself, since he does not enjoy himself. But he enjoys himself all the same, and on the single condition of taking the step that I have just said, namely, that the enjoyment that is at stake, is that of the Other. Naturally, there is a gap. You are not crusaders; you do not consecrate yourself to ensuring that the Other, namely, something or other blind and perhaps dead, should enjoy. But the exhibitionist for his part is interested in that. It is in that way that he is a defender of the faith.

That is why to catch up, I let myself go in speaking about crusaders. To believe in the Other, the cross, the French words [*croisés, croire, croix*] linking up like that. Every tongue has its echoes and its encounters – *croa-croa*, as Jacques Prévert also said - the crusades existed, they were also for the life of a dead God; it would mean something just as interesting to find out what, since 1945, is the game between communism and Gaullism. This has had enormous effects. As long as the knights went on crusades, love could become civilised where they had left the place vacant. While, when they were elsewhere, they encountered civilisation, namely, what they were looking for, a high degree of perversion, and at the same time they reduced everything to rubble. Byzantium has never recovered from the crusades. You have to pay attention to these games because this may still happen, even now, in the name of other crusades.

But let us return to our sadomasochists who are precisely still separated. Namely, that because, as I said earlier, in the scopophilic drive, there is one who succeeds in what has to be created, namely, the enjoyment of the Other, and an other who is only there to fill the hole with his own look, without ensuring that the other even sees there a little bit more about what (213) there is. It is more or less the same case in the relationships between the sadist and the masochist, on the single condition that one notices where the o-object is.

It is strange that, living in an epoch in short where we have resurrected very well all the practices of interrogation, of interrogation at the time that it played a role in judicial mores at a superior level, now that this has been left to operatives who do that in the name of some madness or other like the interests of the country or of the troop, it is curious, after also having seen some little games on the stage with which, after the war in which a lot of things happened, the latest of this type, the pleasure was prolonged a little for us on the stage by showing simulacrums, it is strange that people do not notice the essential function played at first at this level by the word, by confession (*l'aveu*). Despite everything, sadistic games are not simply interesting in the dreams of neurotics. One can all the same see, where it happens, people may well have their reasons, we know very well what must be thought of the reasons, the reasons are secondary as compared to what happens in practice. Whether effectively it is always around something where what is at stake is to peel the subject of what? Of what constitutes him in his fidelity, namely, his word, one could say that this has a part to play in interrogation. It is an approach. I am telling you right away, the o-object is not the word, but it is to put you on the track. Tackling the question from this angle is very open to misunderstanding, as you are going to see right away. Namely, that there is going to be precisely what I reject, namely, a symmetry, namely, that it is certain that the florid, the beautiful, the true masochist, Sacher Masoch himself, organises the whole business in a way that he can no longer speak.

Why does this interest him so much? Let me be frank. What is at stake is the voice. That the masochist should make of the voice of the other just by itself what he is going to give the guarantee of answering like a dog, is essential in the matter. And it is illuminated by the fact that what he seeks out, is precisely a type of other who, on this point of the voice, can be put in question. The dear mother, as Deleuze illustrates, with the cold voice containing all sorts of arbitrary currents, is here something that with the voice, this voice that perhaps he has heard only too much of elsewhere, from his father's side, comes in a way to complete and here also to fill the hole. Only there is something in the voice that is more topologically specified, namely, that nowhere is the subject more interested in the other than through this o-object. And it is indeed there that the topological comparison, the one that is illustrated here by the hole in a sphere which is not one since precisely it is in this hole that it folds back on itself. An attentive examination of what happens at the level of organic structures, very specifically of the vestibular system or the semicircular canals, brings us to these radical forms of which I already gave you a glimpse a fortnight (214) ago by referring to one of the most primitive animals. Let us add to the one that I named the crustacean called the Palemon [*Palaemonias ganteri?*], a pretty name full of mythical echoes. But let it not distract us from the fact that the animal, when, at each moulting, it is stripped of all the outside of its systems, is obliged and with good reason, because otherwise he would not be able to move in any way, to set up, in the hollow opened up at his animal level on the outside, in the hollow of what is nothing less than an ear, some little grains of sand, so that they tickle it in there. It is strictly impossible to conceive what the function of the Superego is if one does not understand – this is not everything but it is one of the mainsprings – the essential of what is involved in the function of the o-object realised by the voice *qua* support of signifying articulation, by the pure voice in so far as it is, yes or no, established in a perverse way or not at the locus of the Other.

If we can speak about a certain moral masochism, this can only be founded on this point of impact of the voice of the Other not in the ear of

the subject but at the level of the Other that he establishes as being completed by the voice. And, in the way that earlier the exhibitionist enjoyed himself, it is in this supplement of the Other - and not without a certain derision being possible which appears in the margins of masochistic functioning - it is at the level of the Other and of the remitting to him of the voice that the functioning axis, the axis of gravitation of the masochist operates. Let me say it. It is enough to have lived in our epoch to grasp, to know, that there is an enjoyment in this remitting to the Other, and all the more when he is less valorised, has less authority, in this remitting to the Other of the function of the voice. In a certain way, this style of evasion, of stealing of enjoyment can be, of all the perverse ones imaginable, the only one that is ever fully successful.

It is certainly not the same when the sadist tries in his way, he also, in the inverse way, to complete the Other, by removing the word from him, certainly, and imposing his voice on him. In general that fails. Let it suffice in this regard to refer to the work of Sade where it is really impossible to eliminate this dimension of the voice, of the word, of discussion, of debate. After all, we are told about all the most extraordinary excesses exercised with respect to the victims as regards whom one can only be surprised by one thing, their unbelievable survival. But there is not a single one of these excesses that is not in a way not simply commented on but in a way fomented from an order about which the most astonishing thing is that moreover it does not provoke any revolt. But after all we have been able to see through historical examples that this is how it can happen. There was apparently never seen in these herds that were pushed towards the crematory furnaces someone who all of a sudden (215) simply bit the wrist of a guard. The operation of the voice finds its full register here, there is only one thing, which is that enjoyment escapes here exactly as in the case of the voyeur. Its place is masked by this astonishing domination of the o-object, but enjoyment for its part is nowhere. It is quite clear that the sadist here is only the instrument of something that is called a supplement given to the Other, but which in this case the Other does not want. He does not want, but he obeys all the

same. Such is the structure of these drives, in as much as they reveal that a topological hole just by itself can fix a whole subjective behaviour and make everything that may be forged around so-called *Einführung* highly relative.

Since the hour is late and since moreover it required a lot of subtlety to get this across, I had to give it all the time necessary, I announce nevertheless that the problem of the neurotic is the following. You can consult the article that I wrote under the title *Remarks on the discourse of Daniel Lagache*. It is indispensable to find our bearings in all the distractions of everything that is said in the Freudian texts about identification. The uncertainty, the clear contradiction there is throughout his works, throughout his statements about what is involved in what he calls *the reservoir of libido*, that sometimes is put forward as the *Ich*, namely narcissism, sometimes on the contrary as the *Id*, the ego being obviously inseparable from narcissism is found in a problematic position. Namely, is it because of the object that it offers the covetousness of the *Id*, that the ego must be said to introduce itself as the effective agency from which there would re-emerge in its turn the interest bestowed on objects.

Is it on the contrary, from the object fomented at the level of the *Id*, that the ego finds itself secondarily valorised, as a fellow, as well as the objects? This introduces us to posing in a radical fashion, to posing again the whole question of what is involved in identification. It is only in so far as the neurotic wants to be the One in the field of the Other, it is only in so far as idealisation plays a primordial logical role that it finds itself from then on confronted with narcissistic problems. But to simply make this remark, that I am suggesting to you at the same time, of asking ourselves whether we are not undergoing, with Freud in imagining primary narcissism, a deferred, imaged effect, even one that is unspeakably falsified. We add a little bit to it, just what is needed to fall into the snare of the neurotic. Namely, that it is in the measure that secondary narcissism, in the form characterised by imaginary capture, is the level where there is presented for him in a way whose problem is

completely different from what is involved for the pervert. This is what I will try to make you sense the next time. It is in the measure that we believe that we are able to think that there was somewhere this relation not of supplement, but of complement for the One and that we invest the oral drive that it presents, nevertheless apparently on the single condition that (216) one is undeceived from the fascination of the neurotic, that there is presented apparently the same character of being centred around a third object which slips away, just as ungraspable in its way as the look or the voice and this famous breast, which with the help of a play on words one makes into the maternal lap. Behind the breast and just as stuck on as it onto the wall that separates the child from the woman, the placenta is there to remind us that far from the child in the body of the mother forming a single body with it, it is not even enclosed in its envelopes. It is not a normal egg. It is broken, broken in this envelope by this element of sticking on through which moreover we now know, there can be bound and played out all the conflicts, that fall under the jurisdiction of 'Byzantism', in the mixture of bloods and the incompatibility of one group with another.

This function of a third object that I call a plaque, or I might say pendant, because we will see it in its outstanding forms in everything that is built up from culture, the thing that is hung on the wall and that lures people. Is this not what appears effectively in the experience of the neurotic? I mean that by converting it, by completing it with the myth of a primitive unity, a lost paradise, supposedly ended by the trauma of birth, we do not fall into what is precisely at stake in the neurotic's affair. What is at stake for him, we will see, I will articulate it in detail and already you can find its first lines sketched in a perfectly clear fashion in this article, is the impossibility of bringing this little o-object onto the imaginary plane in conjunction with the narcissistic image. No representation supports the presence of what is called the *representative of representation*. One sees only too well here the distance, marked by this term, that there is between one and the other. Between the representative and the representation, there is no equivalence. This is what allows me to initiate, to indicate the

point where all of this will be reorganised. The third line of the graph, the one that crosses the two others, is properly speaking what from a symbolic concatenation is carried on to the imaginary where it finds its ballast. It is on this line that in the complete graph you will encounter the ego, desire, the phantasy and finally the specular image before its point, its point which can only here on the left, at the bottom, be grasped as a retroactive effect. Its point only consists in the equally retroactive illusion of a primary narcissism. It is around this that the problem of the neurotic will be re-centred, the manifestation also of the fact that, *qua* neurotic, he is precisely destined to a failure of sublimation. So then, if our formula of S barred diamond o, ($\$ \diamond o$), as formula of the phantasy is to be put forward at the level of sublimation, it is very precisely not before a critique has been brought to bear on a whole series of lateral implications which were given in an unjustified fashion because the experience, which nevertheless could not have taken place otherwise, the experience of the incidences of the signifier on the subject, was carried out at the level of neurotics.

Seminar 17: Wednesday 23 April 1969

(On the board)

Truth on the hither side of thinking, knowledge beyond?

Censorship

Sense – cens

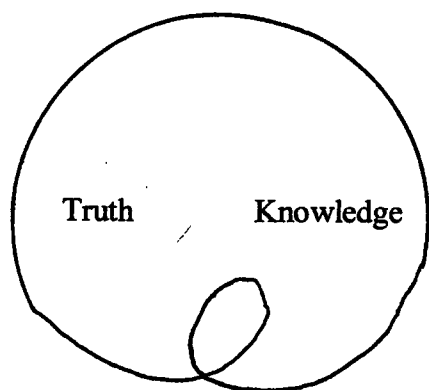

The Klein Bottle

(217) The vacation time interrupted our remarks. As you see, I also took my time in starting up again.

I left you on the subject of sublimation once it had been opened up, and we will have to continue on with some tallying about what is involved, from the point of structure, about what is involved in perversion. To this, I contributed this specification that we have to define, in a way that my schemas, my notions if you wish at a push, make very simple and very accessible. Namely, does the subject, in perversion, himself take care to supply for this flaw in the Other, which is a notion that you do not get into right away, since it requires a certain development of psychoanalytic experience. It is then uniquely for those who are familiar with my terms

that this formula can take on the value of a step forward. This is certainly an inconvenience that is not the privilege of my teaching. It is a common factor in every science from the moment that it begins to be constructed. That is not for all that, of course, enough to authenticate as scientific what my teaching tries to provide against, to provide against something that in the name of a so-called reference to the clinic, always leaves the review of this experience at what one might well call a function reduced to some sort of sniffing out or other. This of course could not be exercised if there were not already given to it the points of an orientation that, for its part, was the (218) fruit of a construction and a very learned one, that of Freud. It is a matter of knowing whether it is enough to lodge oneself in it, and then, starting from there, to let oneself be guided to what one takes to be a more or less living apprehension of the clinic, but which is only quite simply giving a place to what the blackest prejudices regulate in it. That is taken as having a sense. It is to this sense that I think there ought to be applied a rating (*censitaire*) requirement, namely, that those who boast of it should prove themselves with sufficient guarantees taken from elsewhere. I will try to say today why these guarantees ought to be taken from somewhere other than in the field where ordinarily they have done nothing either to authenticate what they have received from Freud concerning what makes up the structure of this field, or – which is indeed the minimum requirement – account for it, in order to try to continue it.

I was among the first to hear about the publication of a scurrilous satire whose title, just by itself, is disgraceful, and I will not mention it here because of that fact. Under the avowed patronage of authors who declare themselves from the first lines to be two analysts, it claims to draw up an account, to measure, to reduce to its value - which does not go any higher than horizons that I must say are despicable, that are the rule in a certain field of psychoanalytic experience - to reduce what is involved to what they call, the name is included in their title, to what they broadly speaking designate as contestation. After that, you know what you can expect! The psychic regression, infirmity, sordid infantilism that is supposed to be shown by all of those who, under whatever heading, manifest themselves

in this register – and God knows how nuanced it can be. These are really brought down to the level of what in a certain field, in a certain frame of psychoanalytic experience, people are capable of thinking. It does not go any further! I will not add another word. Simply I note, I record that, whatever suspicion there may have arisen in some of my most authentic pupils, this does not come from anyone whose face has ever been seen here. It is a fact. It is a fact that I even confirmed, in addressing myself to one or other person who may have fallen under suspicion.

I must say that the very fact of posing this question had something a little offensive about it. But in any case, from where I am, I have to be able to respond, and respond in the firmest way that none of those who, at any time appeared here to collaborate on occasion, to answer me, who to some degree attended this seminar, did anything other than repudiate with horror the slightest approbation that they may have given to this extravagant initiative, to this veritable debuggging of the lowest kind of thinking.

So then these things have been aired. This moreover does not also rule out that, from some quarter, particular people that I am evoking just now may not also engage on a slope that, in the final analysis, does not fail to rejoin (219) what can be expressed in a certain register. That they do not do so, that the whole of French psychoanalysis is not behind the two authors whose names I happen to know through certain communications, and they are not trivial ones, they belong to an eminent Institute that everyone knows, that things are not at the stage that the whole of psychoanalysis is behind them in connection with contestation, after all I can indeed pride myself that it is because of my teaching.

One cannot say that it had much success in psychoanalysis. But, as was said on one occasion at a certain turning point of the adventures, the avatars of this teaching, by one of the very people that I thought I should question, without my suspicions properly speaking going to the point of believing that he would not repudiate this work, it is all the same the same person who, on one of these occasions, in connection with what I was

stating, spoke about nothing less than terrorism. It is supposed to be then the terrorism brought out by my teaching that ensures that French psychoanalysis, after all, let us say, apart from certain rare exceptions, has not distinguished itself either by a great originality, nor by a particularly effective opposition to my teaching, nor by an application of it either. It nevertheless remains that certain types of discourse are impossible because of this teaching. One must really, and this exists, live in a milieu where it is properly speaking forbidden even to thumb through the few pages that I allowed to be published, for such statements to be produced that, I repeat, you will very quickly get to know. If I am speaking about it, it is because a particular weekly that is done by computer already highlights the narcissism imputed in this work to those who carry on a contestation, totally ignoring, of course, the renewal, make no mistake that I brought to this term.

Well then, since there is terrorism and because after all it is not limited to me, that it might perhaps have caught the attention of the authors, for example, that terrorism is not absent from the field they are considering, that it is not simply a search for comfort and reciprocal mirages that governs it. That certainly, in a rather varied way, something is exercised in it that cuts and that excludes, indeed that cuts people off from one another. This reflection, this description of what is an essential and characteristic effect of certain functions in our epoch and very especially of those that, under whatever heading, may be authorised by a school of thought, made me think that I ought to share with you today some reflections that connect very well to this term of what is involved in what must be understood under the register of the customary term that is brandished rightly and wrongly as freedom of thought. What does that mean? How the devil can people even consider that there is a value inscribed in these three words?

(220) As a first approach, let us spell out that if thought has some reference, if we consider it in what we could quickly call its objective relationship, naturally there is not the slightest freedom. The idea of freedom in this quarter of objective references has all the same a core point

around which it arises. It is the function, or more exactly the notion of the norm. From the moment that this notion comes into play, there is introduced correlatively that of exception, indeed even that of transgression. It is here that the function of thinking can take on some sense by introducing the notion of freedom. In a word, it is by thinking about Utopia that, as its name states, is a place that is nowhere, no place, it is in Utopia that thinking would be free to envisage a possible reform of the norm. This indeed is how in the history of thinking from Plato to Thomas More things have been presented. With regard to the norm, the real locus in which it is established, it is only in the field of Utopia that freedom of thought can be exercised. This indeed is what results in the works of the last of those that I have just named, namely, the very creator of the term Utopia, Thomas More. And moreover by going back to the one who put forward, who consecrated under the function of the Idea the term of norm, Plato. Plato at the same time constructs for us a Utopian society, the Republic, where there is expressed freedom of thought with regard to the political norm of its time. Here we find ourselves then in the register not simply of the Idea. And moreover the slightest exercise of everything that I have promoted as distinguishing the imaginary from the real makes us clearly see the framing and formative effect in this register of a reference which goes entirely to its term in the register of the body image. As I underlined, the very idea of macrocosm was always accompanied by a reference to a microcosm that gives it its weight, its sense, its height, its depth, its right, its left. This is the basis of a mode of apprehension described as knowledge, the one in which there is exercised a whole development that quite correctly, is inscribed in the history of thinking.

On my graph where the two horizontal lines that I retraced the last time in order to have them intersected by this hook-shaped line that cuts both of them and determines the four essential crossroads where there is inscribed a certain mapping out. This hook-shaped line that rises and descends to cut both of them, is precisely, I remind you, the line in which there are inscribed and very precisely in the interval left by the two respective lines of stating and stated, in which there are inscribed the properly speaking

imaginary formations, specifically, the function of desire in its relationship to phantasy, and of the ego in its relationship to the specular image. This means that the registers of the symbolic, in so far as they are inscribed in the two horizontal lines are not without a relationship, do not fail to find support in the imaginary function. But what is legitimate about them, I mean what can be rationally assimilated, must remain limited. This is why (221) the Freudian doctrine is a rationalist doctrine; it is uniquely in function of what can be articulated in defensible propositions, in the name of a certain logical reduction, that anything whatsoever can be admitted or on the contrary ruled out.

What is the status, at the point that we are at in science, of this imaginary function taken as a foundation for scientific investigation? It is clear that it is completely foreign to it. In anything we tackle, even at the level of the most concrete sciences, biological sciences for example, what is important is not to know how things are in the ideal case. It is enough to see the embarrassment of having recourse to the thinking that solicits from us every question of this order, namely, what is health for example? You should consider that what organises our scientific advance is not situated in the order of the ideal. What is important, in connection with everything that is and that we have to question, is how it can be replaced.

I think that this is sufficiently illustrated for you by the way it is used with the organic questioning of the functions of the body. It is not by chance, excess, acrobatics, exercise, that what appears to be most clear in the analysis of a particular function, is that one can replace an organ by something that does not look the least bit like it. If I started from an example that is raging today, it is certainly not to create an effect, because what is at stake is of a quite different nature. If this is how things are, it is because science did not develop from the Platonic idea but from a process linked to the reference to mathematics. Not what manifested itself as such at the origin, the Pythagorean one for example to give you an idea, namely, the one that connected the number to an ideal of the sort of those that I was referring to in speaking about Plato. In Pythagoras there is an essence of

the One, an essence of the Two, even of the Three, and at the end of a certain time one comes to a stop. When one gets to Twelve, one is out of breath, this has absolutely nothing to do with the way in which we now question what number is. Between the formulae of Peano and this Pythagorean exercise there is absolutely nothing in common.

The idea of function, in the mathematical sense, but here it is not for nothing that it is homonymous with the style in which I said earlier the organic function could be questioned, this function is always in the final analysis organised from a concatenation between two signifying chains, $x = \text{function of } y$. Here is the starting point, the solid foundation on which mathematics converge, because it did not at all appear so pure at the start. In accordance with the style, properly speaking, of the symbolic chain it is the point of arrival that gives its sense to everything that went before.

In so far as the theory of mathematics, I will not say has culminated, because already it is sliding forward, but let us stay with what constitutes (222) its point of equilibrium in our time, set theory, we note that the essential of numerical ordination is reduced in it to what it is, to its articulatory possibilities. It is constructed to strip this numerical order of all its ideal or idealised privileges, those that I was evoking as I could just now in recalling for you what was the One, the Two, indeed one or other number, in a tradition that we can describe broadly speaking as Gnostic. Set theory precisely is constructed to strip this numerical ordering – and this is what I call of ideal or imaginary privileges – of the unit. There is no trace of the unit in Peano's definitions, a number is defined with respect to zero and the function of the successor. The unit has no privilege in it – of unity, of corporeality, of essentialness, of totality itself. It must be clearly marked by the fact that an example cannot in any way be confused with a class. And by some feature like the fact that to speak about the part is profoundly contrary to the functioning of the theory, that the term sub-set is very precisely constructed to show that one cannot in any way inscribe in it that the whole is made up of the sum of the parts. As you know, sub-sets constitute from their union something that is in no way identifiable to

the set, even by stripping away from it at the foundation, this is the sense of set theory, of recourse to space itself.

I apologise for this introduction designed to mark out the terms of an opposition that is as profound as it is necessary, the one in which there is defined what? The revolution or the subversion if you wish of the movement of a knowledge because, for some time, it is clear that I have taken off from the functioning here which is only inaugural, indeed supposed by thinking. It is indeed because I started from Plato that I could speak about thinking. So then it is not at all from the side of objective orientation that we have to question thinking about its freedom. In that quarter, it is not free, in effect, except in Utopia, which has no place in the real. Only, one of the interests of the very process that I took, is that undoubtedly, this discourse has something to do with thinking. This retreat from what is involved in the two aspects of knowledge, we shall call what? A reflection? A debate? A dialectic? It is in the subjective field, quite obviously, and inasmuch as, if the thing were possible, you would have an occasion to answer me, that we would, no doubt, have to make other diversities intervene.

In the foreground first of all, the notion of "all" (*tous*). In what I have just said what can be accepted by all? Does this "all" have a sense? We will rediscover the same opposition here. We will notice the moulting that logical requirements have taken on, and that moreover, to push such a debate sufficiently far, we would be led, to promote the function of the (223) axiom. Namely, a certain number of logical prefigurations that are held to ground what follows and moreover, to make what follows depend on the assent given or not to the axiom. The uncertainty of this "all" will be put in question not at all simply from the fact that concretely the unanimity of the "all" is the most difficult thing to obtain, but that the

logical expression of the “all” proves to be very precarious, provided that, in the order of logic, we have the order of requirements that necessitates the theory of quantifiers. Pulling back from this, not going to involve myself in developments that would send us astray with respect to what we have to question, I will ask how there is expressed in this register what is involved in freedom of thought.

Here Hegel is a reference point that is not simply convenient but essential. In this axis that interests us, he prolongs the inaugural *cogito*. Thinking surrenders itself if one questions the centre of gravity of what is qualified there as *Selbstbewusstsein*. I know that I think. The *Selbstbewusstsein* is nothing else. Only what he adds to Descartes, is that something varies in this “I know that I think”, and this is the point where I am. This, I was going to say by definition, in Hegel, I do not know. The illusion is that I am where I think. Freedom of thought here, is nothing other than what Hegel forbids me to think about, which is that I am where I want to be. In this respect, what Hegel reveals, is that there is not the slightest freedom of thought. The time of History is necessary so that at the end, I think at the right place, at the place where I will have become Knowledge. But, at that stage, there is absolutely no longer any need for thinking. I am carrying out a rather mad exercise before you because it is obvious, for those who have never opened Hegel, all of this cannot go very far. But in any case I hope all the same that there are among you enough people who are more or less introduced to the dialectic of the master and the slave, to remember what happens to the master who has the freedom – this is how he defines

him at least, he is the mythical master – what happens when he thinks, namely, when he puts his mastery into the strangeness of language. He enters into thinking, perhaps, but undoubtedly it is the moment when he loses his freedom. That the slave, as ‘vile consciousness’, is the one who realises History. In work, his thinking is at every phase the servant of the step that he has to take to accede to the kind of state where there is realised what? The domination of knowledge. It is almost impossible to undo the fascination of Hegel. It is only some people of bad faith who consider that I have promoted Hegelianism within the Freudian debate. Nevertheless, you must not imagine that I think that one can finish with Hegel like that. This notion that the truth of thinking is elsewhere than in itself and is necessitated every moment by the relation of the subject to knowledge, and that this knowledge itself is conditioned by a certain number of necessary phases, is a grid whose applicability we cannot but sense at every instant, at every detour of our experience. It is of exemplary value as an exercise, (224) as a formation. It is really necessary to make an effort at disorganising, of veritable awakening to ask ourselves why, however little I may know it, there is this delay which means that I must think in order to know.

If one looks more closely at it, questions oneself, what does the articulation of effective knowledge with the way in which I think about my liberty matter, namely, “I am where I want”? It is clear from Hegel’s demonstration that I cannot think that I am where I want. But it is no less clear in looking closely at it that it is this and nothing else that is called

thinking. So that this "I am there where I want" which is the essence of freedom of thought as a stating is properly what cannot be stated by anyone. At that moment there appears this strange thing that in Hegel, in the *Phenomenology* and not in the *Encyclopaedia*, but where there is marked in the sharpest way this dialectic proper to thinking, this can be done in the absence of any history of knowledge. In the whole of the *Phenomenology of the spirit*, it is a matter of a reference to a truth that allows to be highlighted what thinking does not know about its function. From then on it is clear that where does Hegel detect it if not from his knowledge, I mean the knowledge of his time, of his epoch, of this scientific knowledge as Kant had accounted for it, Newtonian knowledge. Let us say in a word, for those who understand, this limit-knowledge that marks the apogee and the end of theology.

The difference between Hegel and Freud is the following. Thinking is not simply the question put about the truth of knowledge, which is already a lot and essential in the Hegelian step. Thinking, says Freud, bars the entry to a knowledge. Do I need to recall what is at stake in the unconscious, namely, how the first access to a knowledge had been thought out? The *Selbstbewusstsein* of Hegel, is "I know what I think". The Freudian trauma is an "I do not know", itself unthinkable since it supposes an "I think" dismantled of all thinking. The point of origin, not to be understood developmentally but structurally when it is a matter of understanding the unconscious, is that it is in this nodal point of a failing knowledge that there is born, in the form then of what can be called, on condition that you

put the two last words in a sort of parenthesis, the desire (to know). This is simply unconscious desire in its structure. Moreover, I have for a long time marked on the upper line of my graph “he did not know” in connection with the celebrated dream of “he did not know that he had died”. The “he did not know” is the putting in question of the stating as such of the subject divided at the origin. This is what creates the dimension of desire, being that of the desire of the Other. It is in so far as in the traumatic phantasy this desire of the Other cannot be formulated, that desire takes seed in what can be called, on the condition of putting the last words in parenthesis, the desire (to know). And we find there right away the fundamental themes on which I insisted. If the desire of the (225) Other is such that it is closed off, it is because it is expressed in what is characteristic of the traumatic scene, that the body is glimpsed there as separated from enjoyment. The function of the other is incarnated here. It is this body perceived as separated from enjoyment.

The step that Freud makes us take concerning this function of thinking with respect to *Selbstbewusstsein*, is that the essence of the “I know that I think”, of this *Selbstbewusstsein* is nothing other than the excessive accent that is put on what “I know” while forgetting this “I do not know” which is its real origin. It is already against the division that this “I do not know” implies that the simple fact of the presence of the negation puts in suspense, as I might say – but precisely I am not saying it. It is an “I do not know” that the “I know that I think” is designed to screen in a definitive fashion. The truth henceforth is no longer the place where this

“that I think” in Hegel really is. The truth is the designation of the place from which this “that I think” is motivated. Note that if this ought to be taken in all its rigour, there is nothing to be said about this place which has any sense. It is created by a “that means nothing”. It is the place where “that means nothing” commands a replacement “that means”.

I do not know for how many of you this recalling of these primary truths may be of use. But for the others I put some key words on the board which recall what I have already elucidated at length in a topology. Namely, this reference to the Klein bottle in so far as it gives us in a surface topology the possibility of a division, in which what is at the neck, namely, this little circle, where the surface is supposed to retrogress. And we will put on the one hand the truth and on the other knowledge. Note that in this schematisation there should be here a somewhere that reunites them, that is the same shape as the one that I am trying to make present more simply in the Moebius strip.

What is important is to pose some questions here. This truth which is the one that we question in the unconscious as creative failure of knowledge, as the original point of the desire to know, is the schema that comes from a knowledge condemned never to be in a way anything but the correlate of this failure. Is this not for us, in questioning things further, whether all thinking, and not simply the spontaneous thinking of whoever is oriented in the established realities of life, but thinking as such, namely, as questioning itself on this Hegelian point which is where a certain style of

knowledge really situates the subject. If all of this thinking is defined as being essentially censorship, because this is what the Freudian articulation means, it is that this "I do not know", from the fact that it is radically forgotten, is impossible to return to its place, thinking-censorship, call that what you wish, slide the words, *pensée-censure*. Do we not sense there at least one of these essential correlatives of what is put abroad in our epoch (226) about a so-called end of philosophy?

There is an objection of structure, precisely, which is that philosophy, or even as is better said on occasion metaphysics, metaphysics never did anything but that, to consider itself as at an end. So then it must not be believed that because people bring in Kierkegaard, Marx and Nietzsche, as they say, this takes us so much outside the limits of the blueprint, uniquely seen from this point of view. This is only interesting in order to continue to question what is in our day, you should note it all the same, the most contested thing in the world, even though people arm themselves with nothing else, namely, freedom of thought. Wherever people work to realise something that seems to be the domination of knowledge – I mean where people work seriously, not where it is a fair – there is no freedom of thought. That does not prevent the students in Prague from going on strike for it.

So then what does that mean? It is in the measure that our analytic experience can perhaps contribute here an outline of reflection that this whole discourse is being carried on. If we proceed in experience by

making hold up what? A discourse that is defined how? Free associations, that means without a link to the Other. You speak in analysis. This means that you have been freed from all the rules of the game. And to what, great God, is that going to lead? Not even to an aesthetic text. Because the surrealists, when they wanted to proceed along this path, you can imagine that at the end they made good use of a pair scissors, for that to end up by making something that we will speak about again, the work of art. That one should be able to arrive at it like that is already strongly indicative but quite impermeable to anyone who does not have an idea of the *o*-object.

We are not talking today about the *o*-object. What we are talking about is the following. That in order to give oneself over to such an exercise, that normally can only end up at a profound logical inadequacy – and that is all Freud means in reality when he says that the unconscious does not know the principle of contradiction, the principle of contradiction is something extraordinarily elaborated in logic and that one can even do without in logic, one can construct a whole logic without making use of negation, I am talking about a formal logic in the field of knowledge – if we can use a discourse that is free of logic, it is certainly not unattached to grammar. The fact is that in grammar there must remain something very rich in properties and consequences which ensures that we notice that a phantasy is expressed in nothing better than a sentence which has no sense other than grammatical. That in its operation in any case, as regards the formation of the phantasy, it is only debated grammatically, namely *A child is being beaten*, for example. It is in so far as something is only

censored in it and can only be censored in it from the grammatical (227) structure, namely, the agent for example, that something can operate around this sentence.

The neuroses then revealed the distinction between grammar and logic. It might be a matter of taking a further step and even if they do not reveal it right away, like that, openly, to tell us that if we discover – and this is what I am striving for – the homology of something that one can only know obviously by having done a little logic, the homology of flaws that is demonstrated by a correct logic, namely, one that is not more than a century old. Namely, which ensures that one sees for example that it is from the localisation somewhere of an undecidable that there depends the consistency of one of the most secure systems, namely arithmetic. That there is a homology between these flaws of logic and the structure of desire in so far as it is in the final term a connotation of the knowledge of relationships of the man and the woman by something that is most surprising, through the lack or the non-lack of an organon, of an instrument, in other words the phallus. That the enjoyment of the instrument creates a barrier to the enjoyment that is the enjoyment of the Other in so far as the Other is only represented by a body, in a word, as I stated it, I think, with sufficient force. That there is nothing that can be structured that is properly the sexual act, if this is correctly demonstrated, joins it, buckles it, is something that rejoins truth and knowledge from behind is conceivable. Thinking is precisely this *Vorstellungsrepräsentanz*, this thing that represents the fact that there is something

unrepresentable because barred by the prohibition of enjoyment. At what level? At the most simple, at the organic level. The pleasure principle, is this barrier to enjoyment and nothing else.

That it should be metaphorised in the prohibition of the mother is after all something that is historically contingent and the Oedipus complex itself is only attached to that. But the question lies deeper. Castration, namely, the hole in the apprehension of this "I do not know" as regards the enjoyment of the Other, ought to be rethought as regards its relationships to the widespread, omnipresent effects of our science – these two points that seem to be very far from this dam which ensures that this sex that we speak about all the time, far from taking a step in any solution whatsoever of the field of the erotic, continues rather to obscure it, and marks out more the inadequacy of our reference points - that there is a relationship between that and these effects that I called widespread of our knowledge. Namely, this prodigious unfurling of the relationship to the o-object that the use of our mass-media are only the return, the presentification of, is not this just by itself the indication of what is involved in freedom of thought?

Because suppose that the structure is effectively here that of the Klein bottle, that the limit is effectively this locus of turning inside out where what was the front becomes the back and inversely, where apparently truth (228) is separated from knowledge. Let it be sufficient for us to think that this limit is not fixed, that of its nature it is everywhere, namely, that the question is posed for us of what to do so that there should not be stuck at a

purely imaginary fixed point this division between truth and knowledge. And it is indeed this about which, for want of having even begun to suggest the problem in this way, the psychoanalysts are content to give a demonstration in this form of absolutely not being able to detach themselves from a certain stasis of this limit. Every treatment of neurosis that limits itself to the exhaustion of the identifications of the subject, namely, very precisely of that by which he is reduced to the other, no treatment of these identifications, we will come back to it, carries in itself any promise of resolution of what constitutes the knot for the neurotic.

What constitutes the knot for the neurotic, I will not say here today, I would be forced to go too quickly. But what I mean, is that because of what is involved in the nature of the neurotic, which is profoundly that he is asked what is involved in his desire, can the question not be posed whether the psychoanalyst is not here complicit by sustaining without knowing it the foundation of the structure of the neurotic, namely that his desire can only be sustained from this demand. In a word, curiously, if one can say that analysis consisted in a rupture with hypnosis, it is perhaps for a reason that is quite surprising when one considers it. It is that in analysis, at least in the form in which it stagnates, it is the analyst that is hypnotised. At the end, the analyst ends up by becoming the look and the voice of his patient. This is very different from what is presented, an illusion of thought, as recourse to the clinic. It would perhaps not be separating oneself from the clinic to pay attention to the fact that this mutation does

not take place. I am only, as you can well imagine, indicating the ways that we will push forward in the sessions to come.

I would only like to end by making this remark. If I limited myself in my life to commenting my experience and questioning it in its relationships to Freud's doctrine, it is precisely with the aim of not being a thinker but, a thinking, the one Freud already constituted. To question it while taking into account what determines it, as regards what, speaking in a Hegelian way, constitutes or not its truth.

Seminar 18: Wednesday 30 April 1969

(229) Perhaps some of you, who by chance, might be philosophers, may glimpse that a question that has been put behind us, through some sort of lassitude rather than from having received an effective solution, the one that opens up between the terms of idealism and realism, is being asked again here. As we are going to see later, it is fairly easy to get the measure of idealism, you can pick it up from the writings of those who have proposed this doctrine. You will see that up to a certain point I will take support in something that has not been refuted. It has not been refuted philosophically. This means that common sense which is, of course, realist, realist in the terms that idealism poses the question, namely, that according to it we are only supposed to know the real from representations, it is clear that this position that, from a certain schema, is irrefutable, can all the same be refuted once one does not make of the representation the pure and simple reflection of the real. I am going to come back to it.

It is notable that it is from within philosophy itself that the decisive blows have been dealt against idealism. Namely, that what was put forward first of all in the mythology of representation was able to be displaced into another mythology, the one that puts in question not

representation but the function of thinking *qua* ideology. Idealism could only hold up by confusing the order of thought with that of representation. The matter is articulated, as you see, very simply and one can believe one is a realist by making of thinking what it is, something that is dependent on what is called on this occasion the real. Is this sufficient? It is difficult not to perceive that even within the mythology, that is what I call it, of ideology as dependent on a certain number of conditions and specifically social ones, namely, those of production, is it a position of realism to refer oneself to a real that as such, namely, in the fact that thinking is always dependent on it, cannot by this fact be fully apprehended, and this all the more in that we consider ourselves to be in a position to transform this real properly speaking. These are global reflections. What I want to point out, is that this real with respect to which we ought to consider – this is the sense of what is called the critique of ideology – our knowledge as in progress, is an integral part of the subversion that we are introducing into the real. The question is the following, is this knowledge in progress already there somewhere? It is the question that I posed (230) under the terms of *subject supposed to know*.

It is always as a presupposition and, in a word, a prejudice that is all the less criticised because it has not been seen that, even in excluding what the idea of knowledge indicates in terms of mysticism, even by having understood that the step of science consists properly speaking in having renounced it, by constituting a knowledge which is a system developing from the radical presupposition that we are dealing with nothing other than systems, that the subject does not only handle but in which he can purify himself as such, being nothing more than the support of what is articulated as organised knowledge in a certain discourse, a discourse separate from that of opinion, and that as such is

distinguished from it as a discourse of science. It remains that even when this step has been taken, no serious question has been posed about the implications that, despite ourselves, persist of this prejudice in so far as it is not criticised. Namely, that in order to discover this knowledge ought we, yes or no, to think - a fact of thinking - that there is a place where, whether we want to or not, we conceive of this knowledge as already organised. As long as the consequences properly speaking of a radical putting in suspense of this question of the *subject supposed to know* have not been tested, we remain in idealism and, in a word, in its most backward form. In the one that, when all is said and done, has remained unshaken in a certain structure and that is called, neither more nor less, theology. The *subject supposed to know* is God, full stop, nothing else. And one can be a *savant* of genius, and not, as far as I know, for all that be obscurantist, one can in a word be Einstein, and have recourse in the most articulated way to this God. He has to be already there, supposed to know, since Einstein, arguing against the restructuring of science on the foundations of probability, argues that the knowledge that he articulates in his theory presupposes somewhere, commends itself, by something that is homogenous to what is indeed a supposition concerning this subject. He names him in the traditional terms the good old God, difficult perhaps to penetrate in that he sustains the order of the world, but not a liar. He is fair. He does not change the goalposts during the game.

And it is on this admission that the rules exist already, that somewhere the rules of the game, the one that presides over this deciphering that is called knowledge, are established simply by the fact that the knowledge already exists in God. It is at this level that one can question what results from a veritable atheism, the only one, as you

see, that merits the name, which is the following: is it possible for thinking to sustain the confrontation of the putting in question of the *subject supposed to know*.

This, it must be said, is a putting in question that, though I am reformulating it, in no way means that again this formula here constitutes a step forward in anything whatsoever. Not of course that it is not a step that essentially occupies me. The fact is, in what I have to (231) articulate, which is solidary with it, namely psychoanalysis, I can only manage by getting across first of all what I solicited from the analysts: at least to have an up-to-date discourse about what they are effectively handling. Call that what you want, treatment, analytic experience, it is all one. And, in this respect, their thinking remains backward to the point that it is easy to put your finger on the fact that it is, when all is said and done, to one of the briefest forms of summing up the subject that there are attached particular notions that are by no means harmless. To take account of what the subject does in the treatment, to account for it in terms that by being attached to prejudices that for their part are summary, a veritable degradation of what critical thinking has been able to touch on at one or other of its turning points, is not without multiple consequences. First of all, by reinforcing everything that is signalled to us in thinking as being essentially constituted by a resistance. And then styles of intervention that can only reinforce in the subject described more or less correctly as the patient, but in any case, anyway, treated, woven into the very act of psychoanalytic experience, reinforce the same prejudices in the subject.

And to say what is at stake in a really obvious way, I will focus it on the terms of inside and outside that are evoked. That these terms are,

of course, in Freud's discourse from the origin, is not a reason for us not to question them in the closest possible way. Otherwise we risk seeing being produced these sorts of deviations that hinder what might be glimpsed in analytic experience that is of a nature to nourish or at the very least flow into the essential question, that of the *subject supposed to know*. As long as the *subject supposed to know* before we know has not been put in question in the most serious way, one could say that our whole approach remains attached to what, in a thinking which is not detached from it, is a factor of resistance. Because a defective conception of the terrain on which we pose questions inevitably leads to their radical distortion.

How, with the use that is currently made by the analyst, not simply day by day but every minute, of the terms projection and introjection, how, if they are not criticised in themselves in a correct fashion, how can we not see their inhibiting effect on the thinking of the analyst himself. And much more their suggestive effect in the interpretative intervention and in a style that there is no excess in saying can only be cretinising. Does an inside and an outside, which seem to be self-evident if we consider the organism, namely, an individual who in effect is indeed there - what is inside, is what is in his sack of skin, and what is outside, is all the rest. That from there the step should be taken that what he represents to himself about this outside ought also to be inside the sack of skin is something that, in a first approach, appears a modest, self-evident, step. It is exactly on this after all that there is (232) based the articulation of Bishop Berkeley. After all, about what is on the outside, you only know what is in your head and what will consequently under some heading always be representation. Whatever you may put forward about this world, I can always point out that it comes from the way you represent it to yourself. It is really very

curious that such an image was able to take on, at a moment in history, a dominant character. To the point that a discourse was able to be based on it that effectively, in a certain context, that of a representation that is designed to sustain this idea of representation, could not be refuted. I would like to imagine this representation that allows there to be given to representation this advantage in which there consists, when all is said and done, the secret knot of what is called idealism.

It is certainly quite striking that by simply approaching it in the way that I do, its canvas, as one might say, vacillates. If it is so simple, how were people even able to consider it? And to give body to this vacillation, I am going to do something that is of course required, namely, show how this mirage-representation is constructed. It is the simplest thing there is. There is no need even to have recourse to something that is all the same rather striking, Aristotle's text in his little treatise on *Sense and sensibilia*, to notice the style with which he tackles what is involved in sight, in the eye. What he says about it, where he tackles it from, the way in which he intends to account for the fact of vision, is something that just by itself makes us notice that he is lacking in a striking way what is unquestioned for us. Namely, the most elementary apparatus of optics. This is the time to say what an advantage it would be for a study to be made of the point that ancient science was at about optics, properly speaking. This science went very far, much further even than is believed, in all sorts of mechanical views. But it seems in effect that, on the proper point of optics, it presented a remarkable blank. In this model which gives its status at that time to representation in which the kernel of idealism was crystallised, the very simple model is that of the dark room. Namely, a closed space protected from all light, in which only a little hole opens up to the outside world. If this outside world is illuminated, its image

is depicted and moves around, according to what is happening outside, on the inner wall of the dark room.

It is extremely striking to see that at a certain detour of science, and it is not for nothing that it is Newton's, who as you know was just as inaugurating and brilliant as regards optics as he had been as regards the law of gravitation. It is not for nothing at this turning point that I will recall that what earned him the praise of his time, was very exactly to have been able for – this was articulated by the best minds – the plans of God that he found himself deciphering. This to confirm the remark that I was making earlier about the theological envelope of the first steps of our science. Optics is therefore essential to this (233) imagination of the subject as something in an inside. A singular thing, it seems to be admitted from the place of this little hole on which the site of the image depends. It is enough because this little hole, this place is indifferent. An image will always be produced, in effect, in the dark room opposite the little hole. The difference of the place of the little hole does not appear to give rise to a question about the fact that one only sees the world from the side that the little hole is turned towards. It seems to be implied in this function of the subject modelled on the dark room that, in the room, this apparatus of the little hole should be compatible with the fact that, from what is outside and is only an image since it can no longer be expressed except as an image inside, outside in a space that nothing limits, in principle, everything can come to take up a place within the room. It is nevertheless manifest that if the little holes were multiplied, there would no longer be any image anywhere.

Nevertheless we are not going to insist too heavily on this question, this is not what is important to us. It is simply to remark that here, and

here alone, is the support for the fact that what concerns the psyche is to be situated in an inside limited by a surface. A surface, of course, we are told, is already something in Freud's text. It is a surface turned towards the outside and it is on this surface that we henceforth localise the subject. It is, as they say, defenceless with respect to what is inside which is not of course simply representations but also, since the representations cannot be put elsewhere, at the same time one puts all the rest there, namely, what is called differently, confusedly, affects, instincts, drives. All of that is inside.

What reason is there, to know the relationship of a reality with its locus, whether it is inside or indeed outside. It would be well first of all to question oneself about what it becomes *qua* reality and perhaps for that to detach oneself from this fascinating virtue that there is in the fact that we can only conceive the representation of a living being inside its body. Let us go out of it a moment and let us pose the question of what is happening in the inside and the outside when it is a commodity that is at stake for example. The nature of commodity has been sufficiently illuminated for us for us to know that it is distinguished between use value and exchange value. Exchange value is, all the same, what functions outside. But let us put this commodity in a warehouse. That must also exist. A warehouse is an inside. That is where it is kept, that it is preserved. The barrels of oil, when they are outside, are exchanged and then consumed, use value. It is rather curious that it is when they are inside that they are reduced to their exchange value. In a warehouse, by definition, one is not there to break them up or to consume them; they are kept. The use value on the (234) inside, where one might expect it, is precisely prohibited, and it only subsists there by its exchange value. Where things are more enigmatic, is when it is no longer commodity that is at stake but the

fetish *par excellence* of money. In that case, this thing which has no use value, which has only exchange value, what value does it preserve when it is in a safe? It is nevertheless quite clear that it is put there and that it is kept there. What is this inside that seems to make what is locked up in it completely enigmatic? Is it not in its way, with respect to what constitutes the money, is it not an inside that is altogether outside, outside of what constitutes the essence of the money?

The only interest of these remarks is to introduce what is involved in thinking which also has something to do with exchange value, in other words, circulates. This simple remark should suffice to mark the timeliness of the question for those who have not yet understood that a thinking cannot be properly speaking conceived of unless it is articulated, unless it is inscribed in language, unless it can be sustained in conditions that are called dialectic. This means a certain operation of logic, with rules, and of knowing then if there is any way of us not questioning ourselves in exactly the same way as we were doing a moment ago for the money placed in a safe. What is meant by a thinking when one keeps it to oneself? And if one does not know what it is when one keeps it to oneself, it is all the same because its essence must be elsewhere, namely, already outside, without one needing to make a projection to say that thinking is involved. In other words, something must be noticed that perhaps did not appear right away to everyone. This is that what is convincing in Berkeley's argument, what gives it its force, is perhaps indeed this intuition grounded on a model, I cannot have representation elsewhere. But the important thing in the affair is not that, namely, that we allow ourselves to be caught by another image, and one particularly dependent on a certain state of technique. The fact is that effectively his argumentation is irrefutable. In order for idealism to hold up, there must be not simply Bishop

Berkeley but some other people with whom, on this subject of whether we only have an apprehension of the world that the philosophical limits of idealism defines. It is in the measure that one cannot get out of it, that, in the discourse, one has nothing to retort to it that it is irrefutable.

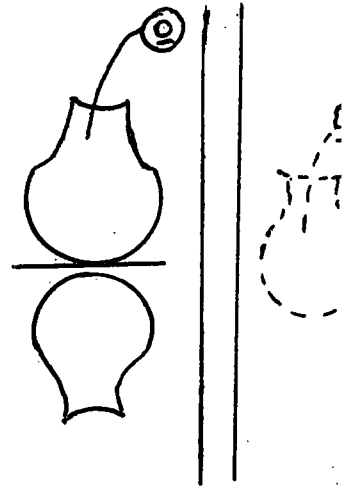

(235) So then on the subject of idealism/realism, there are quite obviously those who are right and those who are wrong. Those who are right are in the real, I am speaking from the realists' point of view; and those who are wrong, where are they? This should also be inscribed in the schema. The important thing is the fact that in the debate, the articulated discussion, Berkeley, at the point that he is at in the philosophical discussion of his epoch, is right, even though, of course, he is clearly wrong.

This is precisely what proves that the first outline of the field of objectivity grounded on the darkroom is false. But then is it necessary or not to substitute another one for it? And how can it be done? What becomes of inside and outside? And if what we are forced to redraw to find ourselves on this limit, on this middle line between the symbolic and the imaginary that a minimum of support, of intuitive support, for our cogitations, demands does this not involve us having, in analytic intervention, to radically abandon these terms of projection and introjection, as we constantly use them without contributing in the slightest to the schema that, in order to designate it, we will call Berkeleyan, the one marked by this little ring on top. This is the darkroom, in which I put the subject of representation with a real outside that is distinguished simply as being, as if it were self-evident, everything that is there outside. It is the real.

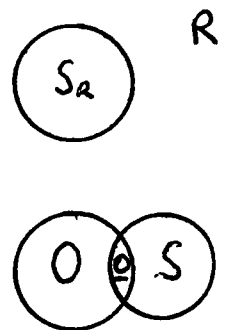

Probably another very unfortunate apprehension of things, because it does not distinguish in everything that is constructed outside different orders of the real. To pose the question simply of what this building, this house owes to an order that is not at all necessarily the real, because we made it, is something it would be well to put in place if we have to intervene in a field that is not at all the one that has been said to be that of elementary, organic, carnal, facts, biological pressures but of something that is called the unconscious. And that by being simply articulated as being of the order of thinking, does not escape from the fact that it is articulated in language terms. The radical character of what is at the foundation not of what I teach but of what I have only to recognise in our daily practice and in Freud's texts, poses the question of what is involved in the inside and the outside, and the way in which we can and ought to conceive of what corresponds to the facts always so awkwardly handled in the terms introjection and projection. To the point that Freud dares, it has to be said, at the origin of the definition of the Ego, to articulate things in these terms. Namely, that starting from a certain state of confusion (236) with the world the psyche is separated out into an inside and an outside. In his discourse, nothing is distinguished about what is involved in this outside, namely, whether it can be identified to what in this representation in common opinion, whether this outside can be identified to this indeterminate space. And this inside to something that we will hold henceforth to ground a rule of the organism all of whose components we are going to find inside.

It is quite clear that one can already take a step, in demonstrating how unthinkable the schema of the darkroom is. There is no need to go back to Aristotle to see that because he does not refer himself to the dark room, the questions are completely different to the ones that are

posed to us and render properly speaking unthinkable the whole conception, let us say, of the nervous system. Read this text, it is piquant, this text with which there begin some chapters of a little treatise that he calls *Sense and sensibilia*. He already touches on the problem, namely, this something that is going to give rise to so many developments subsequently, namely, that there is something in vision that opens out to reflection. He approaches the “seeing oneself seeing” of Valery in the drollest way in the fact that when one puts pressure on an eye, this gives rise to something, it gives rise to phosphenes, namely, something that is like light. It is only there that he finds himself able to apprehend that this eye that sees, also sees itself in a way, since it produces light if you press on it. Many other things are piquant, and the formulae that he ends up with, make the dimension of the diaphanous essential to things. This accounts for the fact that the eye sees from the fact, and uniquely from the fact that, in this order of the diaphanous, it represents a particularly qualified system. Namely, that far from us having something that in any way resembles an inside and an outside, it is in so far, as one might say, as the eye shares a quality that we would describe as visionary (*visionnaire*) that the eye sees. It is not so stupid. It is a certain way, on this occasion, of plunging the subject into the world.

The question has become a little bit different. In truth, the people that Aristotle had to fight with, namely, a thousand other theories stated at his time, all of which moreover, from some point of view, share in something that we have no difficulty in finding in our images, including projection. Because, I ask you, what does this term projection presuppose, when it is a matter no longer of what sees itself but of the imaginary, if not that we suppose, with regard to a certain affective configuration, the one around which, at a particular moment,

at a particular date, we suppose the patient-subject modifies the world. What is this projection if not the supposition of the fact that it is from inside that there begins the luminous pencil that is going to paint the (237) world, just as in ancient times, there were certain people who imagined these rays that, starting from the eye, went on in effect to illuminate the world and objects for us, however enigmatic this radiation of vision was. But we can, we prove it in our metaphors, be still at this point. And when you refer to this Aristotelian text, it is not the least brilliant aspect of what he shows us, that one can put one's finger on in a way, not so much what he constructs himself but everything that he refers to. Empedocles, notably, who makes the eye share in the function of fire, to which he himself retorts by an appeal to the element of water. Incidentally, what is annoying, is that there are only four elements, and since there are five senses, it is hard to see how the link can be made; he says it quite literally. He gets out of it at the end by unifying taste and touch as equally referring to earth, but let us not amuse ourselves any longer, moreover these things have nothing especially comical about them, there are rather exemplary. What appears in a way, in reading these texts, is this something that, for us, localises this field of vision by revivifying it, as I might say, with what we have put into it, thanks to perversion, with the desire that is put into it. One can see this, by simply allowing oneself, as one might say to be impregnated by what animates these texts which, however futile they may appear to us, were nevertheless not produced by stupid people. The mainspring of why they could be said in this way is in a way suggested to us, provided we have done some exercises in what is involved in the visual field in terms of the function of the o-object.

The o-object in the visual field, as regards the objective structure, falls under the jurisdiction of the function of this third term. And it is

striking that the ancients literally do not know what to make of it, miss out on it, even though it is the crudest thing there is. They too found themselves between the two, sensation, namely the subject, and then the world that is sensed. They have to shake themselves, as one might say, to bring into play as third term, quite simply light, the luminous focus in so far as its rays are what are reflected on the object and which, for ourselves, come to form an image inside the darkroom. And then? Then we have this marvellous stupidity of the conscious synthesis which is somewhere, and, it appears, particularly easily thinkable uniquely from the fact that we can lodge it in a cortical fold. And why would the image in the cortical fold become something synthesising, all of a sudden, just because it is in a cortical fold rather than on the retina? The concept of the o-object is sufficiently indicated to us by the very hesitations that are outlined throughout tradition and which ensured in effect that they grasped very well that the solution of the problem of vision is not at all simply light. Light is a condition, of course; for one to see something there must be daylight; but how does (238) this explain the fact that one sees?

The o-object, in what concerns the scotophilic field, if we try to express it at the level of sensibility (*esthésie*), is very exactly what you like, this white or this black, this something lacking behind the image, as one might say, and that we put so easily, by a purely verbal (*logomachique*) effect of synthesis, somewhere in a cortical fold? It is very precisely in so far as something is lacking in what is given as an image of it, that there is the mainspring of which there is only one solution, that, like the o-object, it is precisely *qua* lack and, if you wish, *qua* stain. The definition of the stain, is precisely what, in the field, is distinguished as the hole, as an absence. And we know precisely from zoology that the first appearance of this thing that

astonishes us, which is so well constructed as a little optical apparatus, and that is called an eye, begins in lamellar beings as a stain. Will we make of this stain purely and simply an effect, because light produces stains? This is something certain. We are not at that point. To put the stain as essential and structuring as a place of lack in all vision, to put the stain at the place of the third term of the objectified fields, to put the stain at the place of light as the Ancients could not prevent themselves from doing – and this was their nonsense – here is something that is no longer nonsense. If we see that this effective metaphor, the metaphor of the point denied in the field of vision, as being at the source of what constitutes not its deployment more or less as a mirage but what attaches the subject, in so far as this subject is something whose knowledge is entirely determined by another more radical, more essential lack. This is the one that concerns it *qua* sexed individual, this is what shows how the field of vision is inserted into desire. And after all why is there no means of admitting that what ensures that there is sight, contemplation, all these relationships that have a hold on the speaking being, that all of this only really takes on its attachment, its root, at the very level of that which, by being a stain in this field, can succeed in filling, in completing what is involved in the lack. Of the lack itself perfectly articulated and articulated as lack, namely, the only term thanks to which the speaking being can find its bearings with respect to what is involved in its sexual belonging.

It is at the level of this o-object that there can be conceived this articulated division of the subject into a subject who is wrong because he is in the truth – this is Bishop Berkeley – and another subject who, putting in doubt that thinking is worth anything, in reality proves the fact that thinking is of itself censorship. And that what is important, is to situate the look *qua* subjective, because it does not see. This is how

it can be thought that thinking itself is based on the fact that it is (239) censorship and on this alone. It is this that allows it to articulate itself metaphorically as creating a stain in logical discourse.

What I want to say today at the end of this long articulation - at least I can begin it - is the following. We had remained at the level of perversion founded on a different way of inscribing this outside. This outside, for us, is not a space open to infinity where we put anything whatsoever under the name of real. What we have to deal with, is this Other, which has its status as such. It is certainly not only from the efforts of psychoanalysts that we can articulate this status today as presenting itself to be explored by a simply logical questioning, as marked by a flaw. Which in the schema here, presents the big Other, the sign as giving the term of what is posited at the level of enunciating, of desiring enunciating. The fact is that the response that it gives is very exactly the flaw that this desire represents.

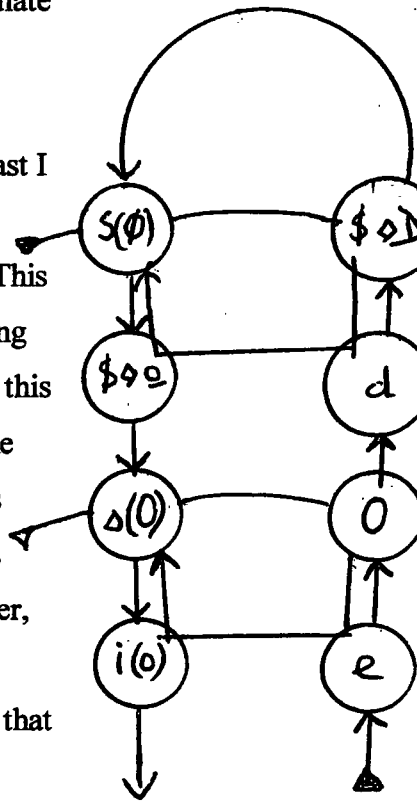

After all, it is not for nothing that these terms are manifested by little letters, by an algebra. What is proper to an algebra is to be able to have different interpretations. $S(\emptyset)$ can mean all sorts of things, up to and including the function of the death of the father. But at a radical level, at the level of bringing logic into our experience, $S(\emptyset)$ is exactly, if it is somewhere and can be fully articulated, what is called structure. If one can in any term qualify as structuralism – and you know the reservations I have about this philosophical label – it is in so far as the relationship between what allows there to be edified a rigorous logic and what on the other hand is shown to us in the unconscious by certain irreducible faults of articulation from which proceeds this very effort that bears witness to the desire to know. As I told you, what I defined as perversion, is in some way the primary restoration, the

restitution, of the *o*, to this field of *O*. This is made possible because this *o* is an effect of the grasping of something primitive, primordial. (240) And why would we not admit it, on condition of not making a subject of it. It is in the measure that this animal being that we were taking earlier at the level of its sack of skin is caught up in language that something in it is determined as *o*, this *o* given over to the Other, as one might say. That indeed is why the other day, in introducing the pervert before you, I compared him to the man of faith, indeed ironically to a crusader; he gives to God his veritable plenitude.

Allow me to end on some rather humorous word play. If it is true that the pervert is the structure of the subject for whom the castration reference, the fact that the woman is distinguished by the fact that she does not have the phallus, that this if filled, masked, completed, by the mysterious operation of the *o*-object, is it not here that there is articulated this formula that I once put forward once. That this way of warding off the radical gap in the order of the signifier that the recourse to castration represents, warding it off is the basis and the principle of the perverse structure. And providing something that completes, that replaces the phallic lack, in providing this Other, in so far as he is asexual, is this not what one day, before you, I designated by the term *l'hommel*? This is a reference that, as regards the basis of a certain outside with regard to the operation of the unconscious, will render you some service by this pinpointing, even though it appears to be simply picturesque.

But to leave you and moreover because today, as usual, I was not able to go through, as usual, as much of the field as I wanted to open up for you. Because this is what leads from perversion to phobia, by seeing in it the intermediary that is going to finally allow you to situate the

neurotic authentically and what is involved at his level by inside and outside. If we write this *hommelle*, by modifying the term which is here, S(O), by modifying it in this sense that it is an unfailing O, that this O of a signifier of O, that is at stake, and which gives the key to perversion, is it not – I will show you more in our next meeting – is it not inversely at the level of the signified s(O) of the flaw, that the division of this O is brought to bear in the neurotic? This is of great interest in topological organisation. Because it also shows that it is at the level of the statement that the text of the neurotic symptom is articulated. Namely, that this is how it is explained that it is between the field of the ego as it is organised in a specular way and that of desire in so far as it is articulated with respect to the field dominated by the o-object that the fate of the neurosis is played out.

This is what we will see better the next time when, founded on the old graphs, I will be able to show you the place taken in the operation of neurosis – I will take it up first of all in the phobia, taking up again everything that I already articulated in connection with little Hans and which was, I noticed, rather inadequately transmitted in the accounts (241) that were given of it..... So then, but if this signified of O *qua* barred, *qua* marked by its logical failure, if it comes to signify itself fully in the neurotic, this is indeed also what enlightens us about the way in which the experience of the neurotic was inaugural. He does not mask what is involved in terms of conflictual articulation at the level of logic itself. That because thinking falters in its own place of well regulated game, this is what gives its true import to the distance that the neurotic himself takes from it in his own experience. And in a word and to end on this wordplay that I announced to you, what is astonishing, if we amuse ourselves with the word *hommelle*, on the stage beneath to transform it into *famil*. The games and the encounters

the state of the tongue allows, is this *famil* not truly something that appears to show us, like a sort of flash between two doors, what is involved in the metaphorical function of the family itself?

If for the pervert, it is necessary that there should be an uncastrated woman, or more exactly if he makes her so and *hommelle*, can it not be noted at the horizon of the field of neurosis that this "He" somewhere, of which the "I" is truly what is at stake in what is involved in the family drama, it is this o-object *qua* liberated. It is what poses all the problems of identification. It is with it that it is necessary, at the level of neurosis, to finish off, so that the structure of what it is a matter of resolving, namely mere structure, the signifier of \emptyset , is revealed.

Seminar 19: Wednesday 7 May 1969

Anxiety, as I once said, is not without an object. This means that this something called objective, starting from a certain conception of the subject, that there is something analogous corresponding to anxiety, something – this is how it is expressed in psychoanalysis – of which anxiety is the signal in the subject. This is the sense of this “not without” in the formula which unveils nothing other than that this term, this something analogous to the object, is not missing. But this “not without” does not designate it; it simply presupposes the support of the fact of the lack. Now any evocation of lack supposes an established symbolic order, more than simply a law, an accumulation, and again a numbered, ordered one, as I underlined at the time.

If we define the real as a sort of thought abolition (*abolition pensée*) of symbolic material, nothing can ever be lacking. The animal, any one whatsoever, that dies because of a succession of perfectly adapted physiological effects, and the fact of calling that the effects of hunger, for example, is completely ruled out; it is the end of the organism *qua* soma. It lacks nothing. It has enough resources within the perimeter of its organism to measure what is described as its mortal reduction. The cadaver is also a real. It is through the effects by which the

organism subsists that we are forced to conceive the imaginary. Something indicates to it that a particular element from the outside, from the milieu, from the *Umwelt* as they say, can be absorbed or more generally is favourable for its preservation. This means that the *Umwelt* is a sort of halo, a double of the organism, and that is all. That is what is called the imaginary. A whole order of the *Umwelt* can be described certainly in terms of adequation; without this the organism would not subsist for an instant. The category of the imaginary implies in itself that this *Umwelt* is capable of failing. But here also, this failure is not a lack of anything. It is the beginning of a succession of effects through which the organism is reduced, like earlier, carrying its *Umwelt* with it. It dies with its mirage which can very well be what is called, it is hard to say why, an epiphenomenon of this hunger that I evoked earlier.

So then up to this everything is reduced to a different level of the structuring of the real. For the fact of lack to appear, it is necessary that it should be said somewhere "it does not add up". For something to be lacking, things must be counted. Once there is something counted, there are also the effects of counting on the order of the image. These are the first steps of *episteme*, of science. The first (244) copulations of the act of counting with the image, is the recognition of a certain number of harmonies, musical ones for example. They give the type of it. This can be noted from lacks that have nothing to do with what, in harmony, are simply posed as intervals. There are places where there is no counting. The whole science that we describe as ancient consists in wagering that these places where there was no counting would be reduced one day in the eyes of the wise man, to the constitutive intervals of musical harmony.

It is a matter of establishing an order of the Other thanks to which the real takes on the status of world, cosmos, implying this harmony. Things were done in this way once there were in the world, in this world of adventure and of concreteness called historical, emporiums, shops where everything is properly arranged. The emporiums and the empires that exist for some time, we are not the ones who invented them, are the same thing. It is the lining and the support of this conception of ancient science that is based, in short, on the fact that was accepted for a long time, that knowledge and power are the same thing. Because the one who knows how to count can divide up, he distributes, and by definition the one who distributes is just. All empires are just. If some doubt has been cast on this recently, there must be a reason for it. The horizon of what is happening here – and this is the excuse for this public discourse, for this something that I continue despite the fact that in principle it is only addressed to psychoanalysts – is something the times bear witness to, something that the wise men do not want to see, something that is already no longer a prodrome but an open tear. That fact is that a discordance has exploded between knowledge and power. It is a matter - it is interesting, in order quite simply for things not to delay any longer in this discordance, with all that it involves in terms of strange stammerings, of restatements, of absurd collisions - it is a matter of defining how this disjunction operates and to name it as such. So that people do not think it can be warded off in some episodic fashion or other by changing whoever is in power. To say that everything is all right because it is those who up to now were oppressed who are now going to exercise it, for example.

Not of course that I am personally setting aside in any way the possibility of this happening. But it seems sure to me that it only has

meaning in as much as it is inscribed in what I have just called the essential change of course, the only one that is of a nature to change the sense of everything that is organised as presumed empire, even if it were knowledge itself, namely, this disjunction between knowledge and power. This formula which has only a crude value, which does not lead properly speaking to anything, which does not consist in any *Weltanschauung*, a utopian presumption or not of a mutation pushed by something or other, ought to be articulated. And it can be, not by reason of the fact that Freud allows it to be grasped, renewing in a (245) system that is in any way comparable to the one that wanted the myth of the conjunction of knowledge and power to perdure. But Freud here is himself much more the patient, the one who, by his word, the word of a patient, testifies to what I am inscribing here under this title, the disjunction between knowledge and power. He does not testify to it alone. He reads it in the symptoms that are produced at a certain level of the subjective. And he tries to ward it off, precisely where it can be read that he himself as well as them, those who testify in their particularity to this disjunction of knowledge and power, he is like them a patient of this effort, of this work, of the testimony given at one point of the effects that I am entitling the disjunction of knowledge and power.

This is how, at the point that I myself am only following this discourse, that in my very discourse I bear witness to what the testing of this conjunction leads to. Namely, to nothing that apparently completes it nor permits it to be hoped that it will ever be reduced to a norm, to a cosmos. This is the sense of what I am trying to pursue before you in terms of a discourse that Freud inaugurated. That is why I began by a careful reading of what this discourse bears witness to, and not simply

in its mastery, because very precisely it is in its inadequacies that it is more instructive.

I re-read the seminar that I gave in 1956-57, a derisory distance of 13 years that, all the same, allows me to measure something of the path that has been taken, by whom? By what? By my discourse on the one hand and then, on the other hand, by a sort of obviousness, a manifestation of a tearing apart that this discourse designates. This, of course, owes nothing to this discourse itself but thanks to it perhaps testimony can be given that there is a discourse that I would not say of course is up to date, let us say is not trailing too far behind what has been produced. This having been said, by reason of the laws that pass as the reigning ones, those described as being of the status of the university, it is necessary in effect that this discourse should not simply be trailing behind but should always be forced to correct itself in principle as *nachträglich*, subsequently. This by reason of the fact that nothing registers it in a renewal of form like the one where there subsists what is involved in terms of major steps taken for some time in knowledge and in such a way that it is marked as an interring disconnected from any effect of power.

We will start again then at the source and this term of o-object that I produced, which was not there in 1956-57 while I was trying to work things out. If this were now published beyond the summary, moreover not so badly done, presented in the *Bulletin de Psychologie* under the heading of *Object relations and Freudian structures*, it could, if it could be done, follow the very text of what throughout more than a trimester I followed the scent of. This text just by itself, so confusing because it is like a labyrinth, attesting to a sort of spelling out, stammering, turning in circles, and in truth, whose outcome, apart from

(246) the fact that little Hans is no longer afraid of horses, and so what? Is the interest of such a research to ensure that one or a thousand little boys are freed from something embarrassing that is called a phobia? Experience proves that phobias do not take any longer to cure spontaneously than with an investigation like the one involved on this occasion, that of his father, a pupil of Freud's and Freud himself. What at that epoch, 13 years ago, I had to underline, I had to spell out, is the real import of what is at stake, in terms of the study of a frontier, of a limit of what is played out at every instant - it goes well beyond the case - the frontier, the limit between the imaginary and the symbolic. And it is here that everything is played out. I will come back to it perhaps to add a few strokes in the course of what I say today.

But let us start again from the point where we have to fix what is involved in the operation of three orders, the real, the symbolic and the imaginary. What is really at stake, this turning point at which we are all patients, whatever may be the misadventures and symptoms of each one of us. Namely, what I am designating as a certain disconnection between knowledge and power. Let us posit somewhere at a point - let us be crude, let us be summary - what I earlier called the real. It is quite obvious that as I described it, it is involved. I have not yet gone to see it but there is, it appears, a film by Louis Malle on Calcutta. In it you see a great number of people dying of hunger. That is what the real is. Where people are dying of hunger, they die of hunger. There is nothing lacking. ~~Why do people start talking about lack?~~ Because they formed ~~part~~ of an empire. ~~Otherwise, it appears, there would not even be a Calcutta. Because it appears - I am not enough of a historian to know but I accept it because we are told that - without the requirements of this Empire there would have been no conurbation in~~

this place. Modern empires allow their dimension of lack to manifest itself precisely in the fact that knowledge achieved a certain growth in them, no doubt a disproportionate one, with respect to the effects of power. The modern empire has also this property that everywhere it stretches its wings, this disconnection also appears. And it is uniquely in the name of this that one can make of the famine in India a motive to incite us to a subversion or a universal revision of something, the Real!

In what concerned the symbolic, it must be counted as at least 1. For a long time, people believed that counting could be reduced to the One. To the One of God – there is only one – to the One of the Empire, to the One of Proclus, to the One of Plotinus. That is why there is nothing excessive in our symbolising the field of the symbolic here by this 1. What has to be grasped, is that of course, this 1 that is not simple and which – that was where the progress took place – people noticed, functioned as a numerical 1, namely, generated an infinity of (247) successors, on condition that there was a zero. This to give an example of the symbolic by one of the systems that are currently best established, it must be emphasised here. The fact is that this counting, whatever it is, at whatever level of structure we may place it in the symbolic, has its effects on the imaginary. And what is established, what is organised in my discourse, for those who follow it by experiencing it, is that these effects of symbolic counting, in the order of the imaginary that we recalled earlier, namely, in the fact that the imaginary is the order through which the real of an organism, namely, a quite established real is completed by an *Umwelt*, counting has, at the level of the imaginary, the effect of making appear in it what I call the o-object.

Now in the human being - and without this making of him a particular exception in the domain of living beings - one image plays a privileged role, as in many other animals. It is the one that is at the source of this dimension that we call narcissism, it is the specular image. We know that this is not limited to men, that among many other animals, at certain levels of their behaviour, of what is called ethology, animal behaviour, images of an apparently equivalent structure, privileged in the same way, exercise a decisive function on the organism.

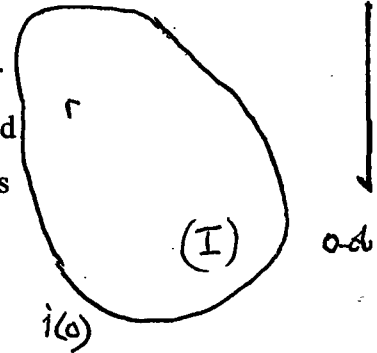

Everything that is observed, articulated by psychoanalysis as a phase in the relationships between $i(o)$ and this o -object, this is the key point that for us is of primary interest, $r: i(o)/o$, to estimate at its value as a model everything that psychoanalysis gives us at the level of symptoms. This in function of what is involved, as is obvious in our epoch, about the effects of disconnection between knowledge and power.

I therefore first defined the o -object as essentially founded on the effects of what happens in the field of the Other, in the symbolic field, in the field of arranging, in the field of order, in the field of the dream of unity, on these malicious effects in the field of the imaginary. Note that this implies the very structure of the field of the Other as such, as I tried, thanks to a schema, to make you sense in more than one of my previous lectures this year. What is indicated here as effect in the field of the imaginary, is nothing other than the fact that this field of the Other is, as I might say, in the form of o . In this field, this is inscribed in a topology that, to image, because of course this is only an intuitive (248) image, presents itself as holding it.

The following step, the one that I made by stating in a way that after all is striking in that when I say things like that, they get across, like

slicing butter – which obviously proves that the analysts have not a very sure idea of what they can hold onto in such a field – I said something simple. Namely, that to bring back these effects of the *o* in the imaginary to the Other, the field that they start from, to render to Caesar as I might say the things that are Caesar's - as was said one day as you know by a little imp, because he was that, the blackguard - was the essence of perversion, to render *o* to the one from whom it comes, the big Other. It is of course a rather apologetic way of presenting things. What has to be known, is what one can draw from it. If effectively something that is the subject, from some quarter, because an effect of the symbolic on the field of the imaginary we can consider still problematic, what place is it going to take? But that touches the subject, we can have no doubt about it, we who make of the subject something that is only inscribed from an articulation of one foot inside and another outside the field of the Other.

Let us try to recognise this aspect of what is at stake about the subject. It is of interest, it is important here to recognise what is involved in a term that Freud put forward, the one that before me had begun to take the dimensions of a certain room whose blackness is much less easy to calibrate than the one that I evoked the last time, the one that served for two centuries in the name of an optical model. That he should have done the circuit several times and given different names to the same things that he found himself discovering after his periplus should not surprise us. Freud spoke a lot about love, keeping the appropriate distance. It is not because this has gone to the heads of those who followed him that we do not have to put things back at the level at which he started them. At the level of love, he distinguished the anaclitic relation and the narcissistic relation. Since it happens that in other places he opposed object cathexis to that of the body, described

as narcissistic on this occasion, people thought they could build on this some type of communicating vases or other thanks to which it is object cathexis that, just by itself, proved that one had got out of oneself, that one had brought the libidinal substance to bear where it should be. It is on this that there reposes this lucubration which that I went through that year, because it was still lively, on object relations, with the whole myth of the so-called oblativ stage, also qualified as genital. It seems to me that what Freud articulates about the anaclitic, about the support taken in the Other, with what it implies about the development of a sort of mythology of dependency, as if this were what was at stake, that the anaclitic takes on its status, its true relationship by defining properly (249) what I am situating in fundamental structure of perversion. Namely, this operation through which the status of the Other is assured by being covered, by being filled, by being masked by a certain operation described as perverse, from the operation of *o* and which by this fact makes a stage of it, by taking – I am saying discursively if we want to give a logical approximation to what is in operation in all sorts of effects that interest us – the anaclitic relation here as being primary. And moreover this is the only foundation by which there can be justified a whole series of supposedly significant clouds through which the child is supposed to long for his paradise in some maternal physiological environment that, properly speaking, never existed in this ideal form. It is only essentially as an operation of this object definable as an effect of the symbolic in the imaginary, as the operation of this imaginary with regard to something that can claim, under some heading, for a while – and in this respect the mother can play this role just as well as anything else whatsoever, the father, an institution, even a desert island. It is as the operation of *o*, as mask, what I called this structure that is the same thing as this *o*, the in-form of *o* of the Other, it is uniquely in this formula that there can be

grasped what one can call the effect of masking, the effect of blinding, that is precisely how the whole anaclitic relation is fulfilled.

To express things in this form, the important thing is not what it says because, as you can grasp, it is not easy to get into, precisely on the plane of what is called imagination. Because living imagination, the one from which we take, pick up what we avidly call varyingly pleasant meanings, depends on a completely different sort of image, and one much less obscure, the specular image. Much less obscure especially since our mirrors have become clear. We will never know, unless we reflect a little bit on it, what we owe to the emergence of clear mirrors. Every time that, in Antiquity, and this continues of course in the time of the Fathers of the Church, you see something indicated as being in a mirror that means something completely different to what it is for us. Their mirrors, because they were polished metal, gave much more obscure effects, this is perhaps what allowed there to subsist for such a long time a specular vision of the world. The world might well appear obscure to them, as for us, but this went along quite well with what was seen in the mirror. That was able to make the idea of a cosmos last for a rather long time, it was enough simply to perfect mirrors. It is because we have done so, along with other things, the elucidation of the symbolic, precisely, that things appear less simple to us.

Let us note that in this we have not yet advanced very far but, since it is knowledge that is at stake, let us observe that the order of satisfaction rendered to the Other, by way of this inclusion of the *o*, the (250) novelty, the one that analytic experience allows us to envisage. It is very precisely this that, whoever he may be, the one that finds himself in the role, in the position of functioning as this Other, from all

time, as long as he has been functioning, never knew anything about what was happening there. This is what I allow myself to articulate under some heading here and there, by posing insidious questions to theologians, of the type as to whether, for example, it is all that sure that God believes in God. If the question introduced as fundamental in any psychoanalytic approach is thinkable – I believe I formulated it along the line of something that, like all prodromes, had begun to be outlined at a certain philosophical turning point – the fact is that the interesting thing, in an altogether living fashion, and this in the measure that the impasses in which knowledge corners us progresses, is not to know what the Other knows. It is to know what he wants. Namely, with his form, his form in-form of *o* (*en-forme de a*), which is outlined quite differently than in a mirror. But in an exploration of perversion that has, moreover, scarcely been touched on, which makes us say that this topology that is outlined, and that the advance of knowledge specifies at many other levels than that of pathological experiences, means what? Where does it lead? It is not moreover quite the same thing. The question is still being studied. If one imagines that even as regards perversions, psychoanalysis closes the circle, that it has found the last word, even by using the *o*-object relation in a more applied way than I can do here, one would be wrong.

The important thing, is to take up, under the heading of symptoms that in a way enlighten us about what is involved in the relationships of the subject to the Other, ancient themes which are not the same at different epochs. And if I have not been able to make room here for Angelus Silesius of the *Cherubinic Pilgrim* whom I made such use of at one time in those lost years - and I do not know whether one day someone will be able to measure out the journey along which I brought to light the precarious sequence of this discourse - whom I made such use of, it

is in the light of this relation that I define as anaclitic that there can be taken up the demistichs of his Cherubinic pilgrim, these distichs cut, balanced in four parts in which there is outlined the proper identity of what appeared most essential for him, what was impossible to grasp otherwise than in terms of the o-object and of God himself. Suffice it to note that everything that can be inscribed in function of order, of hierarchy and moreover of division, everything that is of the order of this fact of exchange, of transitivity, of identification itself, all of this depends on the quite different relation that we posit as specular. All of this refers to the status of the body image in so far as it is posited at a radical turning point as linked to this essential thing in the libidinal economy, considered as being the mastery of the motor activity of the body. It is not for nothing that the same consonants are found in the (251) one and the other, mastery of motor activity (*maîtrise motrice*), everything is there. And it is through this that witness is born on every occasion to what is called good behaviour. Thanks to this mastery of motor activity, the organism qualified from its relationships to the symbolic, man on this occasion as he is called, moves about without ever leaving an arena that is well defined by the fact that it prohibits a properly central region which is that of enjoyment. It is there that the body image as I organise it from the narcissistic relation takes on its importance.

Consult the schema that I gave under the title of remarks to some propositions of a gentleman whose name will survive thanks to me. You will see there that the relationship that is designated is very properly the following. From the relationship that is established of the subject to the field of the Other, in so far as here I cannot do anything other in an image than something homogeneous to common space, and it is indeed for this reason that I make the Other function there. And

why not, because moreover it is not withdrawn from the imaginary, like a mirror. This with the only purpose of being able to posit the second term. The signifier for whom the subject is represented by another signifier, is found there to be highlighted at a place that is none other than the one that I designate here by this enigmatic I [*in French*], from which there is presented the conjunction in another mirror, the conjunction of the *o* and the body image. This precisely designates what happens in phobia.

If we take any observation of phobia whatsoever, provided it is a little bit serious, which is the case, one cannot afford the luxury of publishing an observation in psychoanalysis without a rather complete anamnesis. To take for example in the book by Helene Deutsch on the *Psychoanalysis of the neuroses* the chapters that refer to phobia, what do we see, for example, by taking any of them? She was asked to treat someone because he had at a particular moment a phobia about hens. What do we see? The matter is perfectly articulated, but is only revealed of course, in a second phase of exploration. Namely, that at a time before the emergence of the symptom, hens were certainly not indifferent for him. They were birds that he looked after with his mother and from whom he also collected eggs. We are given all the details, namely, that in the way in effect of all of those who work with these fowl, feeling the cloaca from the outside is enough to see whether the egg is there, and ready to be laid. After that you just have to wait. This indeed is what interested the little the X in question to the highest degree. Namely that when he was being washed by his mother, he asked her to do the same thing to his own perineum. How can one not recognise that at this very place he points to himself as aspiring precisely to furnish the object of what no doubt, for reasons that are not otherwise explored but that are quite tangible there, were the object of

a quite particular interest for the mother. The first phase, (252) is quite obviously "since you are interested in eggs I'm going to have to lay some for you". But moreover it is not for nothing that the egg here takes on all its weight. If it can happen that the o-object is thus involved, it is indeed in this sense that there is what I might call a demographic aspect of the relationships between the subjects which implies that, naturally, what is born is found in place of an egg.

I repeat, I am only evoking this moment in order to give right away the sense of what is going to be at stake when the phobia is unleashed. An older brother, much older in fact, much stronger than him, takes hold of him one day from behind, and this boy who knows perfectly well of course everything that is happening in the farmyard, says to him: "I'm the cock and you're the hen". He defends himself and fights back with the greatest energy declaring: "I won't be the hen!" Note that this "hen" in English, has exactly the same pronunciation with the aspiration as the "n" of the "un" that I spoke to you about earlier. He does not want to be the "hen". There was already someone called Alain who thought he made a great discovery when he said that to think, is to say no. He says no. Why does he say no when earlier he was so happy with his mother at being able to be for her, as I might say, an extra hen, a deluxe hen, one that was not in the farmyard, if not because narcissism is involved there. Namely, the rivalry with his brother, the passage, as has been well proved, to a power relation. The other holds him by the waist, by the hips, immobilises him and keeps him in a certain position as long as he wants.

The transfer (*virement*), I am not saying the tacking (*virage*), of what is invested in a certain meaning between one register and the other is the point at which the earlier function comes to grief. There comes to birth

the fact that the hen is henceforth going to take on for him a perfectly signifying function, and no longer an imaginary one. Namely, that she frightens him. The passage from the field of anxiety, the one by which I inaugurated my discourse today, namely, that it is not without an object, on condition that one sees that this object is what is involved for the subject in the field of narcissism. It is here that there is unveiled the true function of phobia which is to substitute for the object of anxiety a signifier which is frightening. As compared to the enigma of anxiety, the relation to the danger that is signalled is reassuring. Moreover what this experience shows us, is that on condition that there is produced this passage to the field of the Other, the signifier is presented as what it is with respect to narcissism, namely, devouring. And it is indeed here that there originates the type of prevalence that the oral drive has taken on in the classical theory.

What I wanted to begin today, is properly speaking the following. That it in phobia that we can see not at all something that is a clinical entity but that is in a way a sort of turntable. It is by elucidating its relationships with what it most commonly veers towards, namely, the two great orders of neurosis, hysteria and obsessional neurosis, but also (253) by the junction that it realises with the structure of perversion, that this phobia enlightens us about what is involved in all sorts of consequences that have no need to be limited to a particular subject to be perfectly perceptible. Because it is not a matter of something that can be isolated from the clinical point of view but much more rather a figure clinically illustrated in a brilliant fashion no doubt, but in infinitely diverse contexts. It is from the point of this phobia that we will question again what we started from today, namely, the disjunction between knowledge and power.

Seminar 20: Wednesday 14 May 1969

(255) It is impossible not to consider the incidence of the subject as primary in psychoanalytic practice. It is ceaselessly in the forefront in the way, to listen to him, the psychoanalyst thinks, at least if we keep to what is reported. It is from a particular point defined by what is called an identification that the subject is found to act, for example, to manifest a particular intention. A particular paradoxical behaviour will be stated to come from the fact that he goes back, for example, to himself, and from what point if not from another that he had been taking up. He goes back, to the place of someone to whom he is going to be identified, his first aggression. In short, at every instant the subject presents himself as provided with what is at least a curious autonomy, a mobility, especially, equal to none. Because there is almost no point in the world of his partners, whether or not they are considered as his fellows, that he cannot occupy, at least, I repeat, in a thinking that tends to account for a particular paradox in his behaviour. Let us say that the subject – and here there is no place, in this literature, to contest the legitimacy of this term – the subject is moreover absolutely not criticised. At the end in fact there are produced these singular statements that go as far as to talk about choice of neurosis, as if at one moment it was to some privileged point or

other of this pulverised subject that the switching of points was reserved.

Naturally, it can be admitted that, in a first phase of analytic research, we were not in any way in a phase when there could be articulated in any kind of logical way what might be involved, in effect, in what presents itself as being apparently altogether determining at the beginning of an anamnesis, in a certain way of reacting to trauma. It would be enough perhaps to see that this point considered as original, directive in an anamnesis, is a point that was well and truly produced retroactively by the totality of interpretations. I am not talking only about the interpretations that the psychoanalyst makes, as they say, in his head or when he is writing his observation, but where he has intervened in what links him to the patient. This register, this register of questioning, of suspension of what is involved in the subject, is far from being able in any way to be purely and simply described as a relationship of one power to another, even when subjected to all that can be imagined there about the transference.

(256) That is why it is always essential to take up again the question of structure in psychoanalysis at the level of the subject. It is what constitutes the real progress. It is, of course, the only thing that can make what is improperly called the clinic progress. I hope that no one is deceived and that if, the last time, you were able to take some pleasure in seeing my discourse being illuminated at the end by the evocation of a case, it is not specifically the fact that a case was evoked that constitutes the clinical character of what is stated in this teaching.

Let us take things up then at the point where we can formulate them after having on several occasions, on several occasions, marked how

there is formed, from a first and very simple definition, namely, that where we start from is a signifier. This is where we start from, this is where we start from because after all the only element analysis gives us certainty about - and I must say that it gives it its full relief - gives its weight to, is the signifier. If one defines the signifier, *the signifier is what represents the subject for another signifier*. Here is the formula, the originating formula, as I might say, that allows us to situate correctly what is involved in a subject, which we would not in any way be able to handle according to formulae that are apparently those of common sense, of good sense. Namely, that there is indeed some thing that constitutes this identity that differentiates this gentleman here from his neighbour. By being satisfied with this, we find ourselves in fact making every statement, every simple descriptive statement of what effectively happens in the analytic relation look like a puppet show. In it, I repeat, the subject is as mobile as the word itself, the very word of the master of these so-called puppets. Namely, that when he talks in the name of the one that he is holding in his right hand, he cannot at the same time speak in the name of the other one. But he is in fact capable of passing from one to the other with the rapidity that we know.

Here then is something that has already been sufficiently described here for me not to have to redo its whole construction and commentary, the first relationship that moreover is pregnant with all the others, from S_1 to S_2 , from this signifier that represents the subject for another signifier. In the effort that we make to circumscribe what is involved as regards the other of these signifiers, we try, as we have already written, to open up the field in which everything that is second signifier, namely, the body, at the level of which the subject is going to be represented by a signifier, to inscribe at the locus of O, this locus

which is the big Other. I think that you sufficiently remember that by writing what is involved in this way, all we can do, at the level of the very inscription of S_2 , is to repeat that for everything that follows, namely, everything that may be inscribed subsequently, we must put the mark of O again as locus of inscription. Namely, to see in short there being hollowed out from what I called the last time the in-form (*l'en-forme*) of this O - a new noun that we are making up for our own (257) use, *the in-form* of O - the o that holes it.

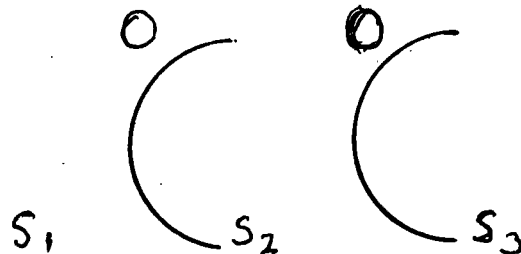

Let us pause for a moment at something that I consider as sufficiently understood because of having been - I had some testimony of it - tangible to some people who found some evidence, I mean in clinical work, for this *in-form* of O, a formula designed to show what is really involved in o. Namely, the topological structure of O itself, which means that the O is not complete, is not identifiable in any case to a 1, to a whole. In a word that this O is absolutely to be felt, to be represented, as if it were at the level of paradox, the paradox that logicians had good reason for creating, the paradox of the set described as that of all the sets that do not contain themselves. I think that you have already handled this paradox sufficiently. It is quite clear that as regards this set of all the sets that do not contain themselves, we have either one thing or the other. Either it is going to contain itself and that is a contradiction, or it does not contain itself, so then not being one of those that does not contain itself, it contains itself, and we find ourselves before a second contradiction. This is quite simple to resolve: the set of all the sets that do not contain themselves can only

in effect be written as a function in the following form. Namely E, having as a characteristic this x in so far as it is different from x .

$$E(x \neq x).$$

Now this is where it overlaps our difficulty with the big Other. If the big Other presents this topological character which means that its *in-form* is o , and we are going to be able to touch very directly what that means, it is because it is true. It is because it must be posited that, whatever may be the conventional usage that is made of it in mathematics, the signifier cannot in any case be held to be able to designate itself. S_1 or S_2 in themselves are not each, in any way, cannot be, the representative of themselves except by being distinguished from themselves. This alterity of the signifier to itself is properly what is designated by the term of big Other marked by an O. If we inscribe this big Other, marked by an O, if we make of it a signifier, what it designates is the signifier as Other. The first Other there is, the first encountered in the field of the signifier is radically other, namely, other than itself. It introduces the Other as such into its inscription, as separated from this inscription itself.

This O, *qua* exterior to S_2 that inscribes it, is the *in-form* of O, namely, the same thing as o . Now this o , as we know, is the subject itself in (258) so far as it can only be represented by a representative that is S_1 on this occasion. The first otherness, is that of the signifier which can only express the subject in the form of what we have learned to circumscribe in analytic practice in terms of a particular strangeness. And it is this that I would like, I would say not to open up today because moreover in a seminar that I gave at one time, it was in the year 1961-62, on *Identification*, I laid its foundations. It is these foundations themselves that I am recalling, simply summarised and brought together today, to make you sense something that is not to be

taken as given to any analyst, of course, except by analytic experience. He knows what is involved in this *o* as essential to the subject and as marked by this strangeness. Besides I already enumerated these *o*'s long enough ago for it to be well known, from the breast to excrement, from the voice to the look, what is meant in its ambiguity by the word strangeness, with its affective note and also its indication of a topological margin. What is at stake, is to make those who do not have this as a datum of experience sense something or other that can evoke its reasonable place in the reference points of what is considered as practical experience – wrongly, it is no more practical than analytic experience. But let's go! What might be least strange in appearance could represent the subject for us here. Take it, at the start, as being as undetermined as you wish. What distinguishes the one who is here from the one who is there and who is only his neighbour, of course, we can grasp. We can make a start on it, from something that is supposed to be not strange at all, from a type of quite common material. This is what I did when I was talking about identification, I designated the trace (*trace*). The trace means something, the trace of a hand, the trace of a foot, an imprint. Observe carefully here, at this level, that trace is distinguished from signifier differently to what in our definitions we have already distinguished as sign. The sign, I said, is what represents something for someone. Here there is no need for someone. A track is sufficient in itself. And starting from there are we going to be able to situate what is involved in what I called earlier the essence of the subject?

We can here and now posit that what the trace becomes through metaphor, the sign if you wish, through metaphor also, these words are not in the right place because I have just ruled them out, what a subject signifies *qua* this trace, this sign, contrary to the natural trace has no

other support than the *in-form* O. What does that mean? The trace passes on to the *in-form* of O the ways (*façons*) in which it was effaced. The subject is the very ways by which, as imprint, the track finds itself effaced. A witticism that I already pinned to this remark, entitling what could be said about it: the four effacings of the subject (*les quatre effaçons du sujet*). The subject is the one that effaces the trace, by transforming it into look, look to be understood as slit, half glimpse. It is through this that he tackles what is involved in the other who has left the trace. He has passed that way, he is beyond.

(259) It is not enough to say, of course, that a subject as such does not leave a trace. What defines him and at the same time delivers him (*le livre*), is first of all something through which he is effectively distinguished. As compared to any living organism what is involved in the animal that speaks, is that he can efface them, and efface them as such, as being his tracks (*traces*). This is enough for him to be able to make of them something other than tracks, rendezvous' that he gives himself, for example. When Tom Thumb lays a trail of white pebbles, it is something different to a track. You should sense here the difference that is already being outlined in the pack that, in pursuing something, behaves in a particular way, make no mistake about it, but behaves in a way that is inscribed in the order of smell, of sniffing, as they say. And this is not necessarily foreign to the human animal himself. But this behaviour is different to the scansion of a track that has been mapped out as such on the support of the voice.

Here you are touching the limit. At the level of the pack, who would dare to sustain that their baying covers their tracks? It is all the same already what can be called an outline of the word. But it is distinct, this support of the voice is distinct, this the datum of the voice, where

there is language, where there is this support that characterises in an autonomous way a certain type of track. A creature that can read its tracks is able through this to re-inscribe himself elsewhere than where he found them. This re-inscription is the link that makes him henceforth dependent on another whose structure does not depend on him.

Everything opens up to what belongs to the register of the subject defined as "what effaces his tracks". The subject, at the limit and to make you sense the original dimension of what is at stake, I would call him the one that replaces his tracks by his signature. And you know, a signature, not much is asked to constitute someone as a subject. An illiterate at the *mairie* who does not know how to write, it is enough for him to make a cross, a symbol of the bar barred, of the effaced track, the clearest form of what is at stake. When first you leave a sign and then something cancels it, that is enough as a signature. And the fact that it is the same for whoever is asked for it, changes nothing in the fact that this will be accepted to authenticate the act in question, the presence well and truly of someone who, juridically, is held to be a subject. Nothing more and nothing less but whose level I am trying to define, certainly not to make an absolute of it but precisely to mark its links of dependency. Because the remark begins here. The signifier is born from effaced tracks. What is then the consequence of this? It is that these effaced tracks are only worthwhile through the system of others, whether they are similar or the same. It is only in these others established in a system, that there begins the typical import of language. These effaced tracks are the only ones accepted. Accepted by whom? Well then, here we land on our feet again. In the same way (260) that in the definition of the subject a signifier represents for another signifier, they are the only ones accepted by whom? Answer:

By the other traces. A *pa-âte* does not count, as Bricolage says in *The marriage*. That indeed is why he takes such an interest in it because for him, Bricolage, who takes tracks seriously, it might count. It is a step taken in haste (*pas hâte*).

So then, if we know that these traces, these traces that are only effaced because they are there, an effaced embossing, these traces that have a different support that is properly the *in-form* of O in so far as it is necessitated by the fact that it makes an O, an O that functions at the level of the subject, we have then to consider them from the level of their substance. This indeed is what constitutes the import of an element like a look, for example, in eroticism and that the question arises, because it is tangible, of the relationship between what is inscribed in the look and the trace. Does an erotic look leave traces where it is inscribed, in the other, namely, in someone else? It is at this level that there is posed, inserted, the dimension of shame. It is demonstrated here in a tangible fashion. Shame is simply a dimension proper to the subject as such.

Will we briefly, at this turn, organise in a way that is a little different to the usual litany, this relation of the signifier to the *in-form* of O? Certainly yes, even though rapidly, to recall that it is not by chance that, at the high point of our contemporary life, writing is affirmed to be a relationship of writing to the look as o-object. This alone is what gives its correct status to a grammatology. The look, in all the ambiguity that I already marked earlier in connection with the relationship to the track, the glimpse and, in a word, the cut in what is seen, the thing that opens out beyond the seen. Undoubtedly the accent to be put on writing is capital for a correct evaluation of what is involved in language. And that writing is first and ought to be

considered as such with regard to speech, is something after all that can be considered not simply as licit but made obvious by the simple existence of a writing like Chinese where it is clear that what is of the order of apprehension of the look is not unrelated to what is translated into the voice. Namely, that there are phonetic elements, but that there are many also that are not so. This is all the more striking in that, from the point of view of structure, of the strict structure of what is involved in a language, no tongue holds up in a purer fashion than this Chinese tongue where every morphological element is reduced to a phoneme. So then it is there that it would have been most simple, to say that writing is only a transcription of what is stated in words. It is striking to see that, quite the contrary, writing, far from being a transcription, is a different system, a system to which eventually there is attached what is cut up in a different support, that of the voice.

(261) Undoubtedly, the term cut is what predestines these supports, definable materially as look and voice, what predestines them to this function of being what, replacing the track, establishes this sort of totality from which a topology is constructed as defining the Other, at its term. As you see, only substructural considerations are involved here. Not at all, of course, original ones because, after all, this does not say how this Other began. It says how it holds together when it is there. Where it originated, is indeed something that up to the present is left in parenthesis. A marginal remark, because I continue, after this 1 and 2 concerning look and voice, to say what can come subsequently in an approach taken from this angle. It is not, as you see, immediately in the relationship of the subject to the Other *qua* structured that there comes what is announced now as *demand*.

It is a curious thing that while in the order of the o-object the breast and the waste product seem to come in the forefront, to the point almost of leaving in a certain shade, in the most frequent handling of what is at stake in analytic regression, the terms of look and of voice, you see here that we are forced on the contrary to suppose as constructed on the support of look and voice, what is going to be of course an element in the demand. And if we rediscover an o-object here, it is for all that an opportunity to highlight that what is demanded is never anything but a place. And it is not for nothing that place evokes this sticking on (*placage*) which is the essence from which we define the breast as analogous to the placenta, in so far as it defines the subjective relationship founded, as it should be established, on the relationships of the child to the mother. The amboceptor role of the breast between the child and the mother is in reality a prevalent role. It is *qua* o-object, in so far as he is stuck onto its wall, that the child-subject is articulated, that his message is received from the mother and he is answered. The third term is what one asks for with these signifiers, and you see its link with this other element "o".

Finally, by articulating things from this angle, we will see, we will put our finger on the fact that what is generated, namely, any sense, the signified properly speaking, it is as an effect of a fall from this operation that it is to be situated here. Sense, which is not simply an effect but a rejected effect, an effect that is carried away, and moreover an effect that accumulates, culture in a word, participates in this something that flows from an economy founded on the structure of the o-object. Namely, that it is indeed as waste product, as excrement of the subjective relation as such, that what gives material for dictionaries, about what is said to be the accumulation of senses that have been concentrated around a signifier, in the course of a certain

recordable practice, as having become common, it is indeed in the register of the second o-object, of the anal object that it must here be inscribed, in this perspective.

(262) Such are the four fashions/effacings (*effaçons*), in which the subject can be inscribed, the subject that, in the middle of this, is of course properly speaking ungraspable because of only able to be represented by a representative. It is in so far as it is inscribed in the field of the Other that it subsists, and this is what we have to deal with if we want to account in a correct fashion for what is at stake in psychoanalysis. The distance can be measured between what is defined as a subject and what is held to be a person. The distance can be measured, namely, they must be very severely distinguished. Every kind of personalism in psychoanalysis lends itself to every deviation, to every confusion. In the psychoanalytic perspective, what is defined, marked, in other registers described as moral, as being the person, we cannot situate at any other level than that of symptom. The person begins where, of course, this subject as I have situated it for you, is differently anchored, is anchored in a much broader way, the one that brings into play what, no doubt, is placed at its origin, namely, enjoyment.

It is because analytic experience teaches us here to outline differently the cartographical atlas, as I might say, of what is involved in these operations that refer to the subject, that it takes on its importance. It is in this that it inaugurates a method. It does not claim to reconstitute any new whole, but assuredly, here and now it upsets the old systems of projection that constituted a whole.

Obviously there should here be pointed out in the margin all sorts of indications that are suggestions, indices. An important point in the meaning of the index, in a discovery in progress, is assuredly something quite different to the way we are able to distinguish it, for example, in the tongue. To make of it something distinctive in a certain sort of signifying indication, that I propose to those who may here have a penchant to come back to what Freud stated in *Group psychology and analysis of the ego*. To consider the degree to which the chief, the leader, the key element in identification as he states it, becomes clearer in this perspective in that there is shown there the solution that makes possible the way in which the subject is strictly identified to o. In other words that he becomes what he truly is, namely, a subject that is itself barred.

What we have seen and what henceforth ought to be considered by us as always being able to be reproduced, the passage from a whole mass to the function of univocal look, as I might say, is something that can only be accounted for by the perception of the possibilities offered in this register to the signifier that is privileged by being the most summary one, by being reduced to what Freud designates as being purely and simply the mark, the function of the 1 as unique. Now here then is the system to which thinking is entirely subject. From it, you should clearly sense, there is no question in any case of anything that can be articulated, and specifically as knowledge, going outside it. The consequences on something living of language, the system of signifiers, enveloping it, is very specifically that starting from it, the image is always more or less marked by being assumed into the system as signifying. This is necessary from the function of the type, and of what is called the universal.

Why is it not tangible? Why has it not yet become common, and why is it not yet in some way effective in the renewal of institutions, that the fact that the images are taken up in the operation of the signifier is there to make us sensitive, the whole of psychoanalytic experience bears witness to it, to the fact that what is lost there, is the imaginary function in so far as it corresponds to the harmony of male and female. If there is something that analysis demonstrates it is that it is because of the grip in the subject not simply that everything that can be designated as male is ambiguous, indeed can be revoked when closely criticised, but that it is just as true on the other side. And that this is sanctioned by a very specific fact of experience that at the level of the subject, there is no recognition as such of the male by the female nor of the female by the male. Everything that any kind of deep exploration shows us about the history of the couple, is that identifications are multiple, overlapping one another and always at the end forming a composite whole. The ambiguity that remains about everything that could be inscribed in the signifier about what is involved in what distinguishes radically, as we know, at the biological level – when I say radically I am omitting of course at the level of mammals the characteristics described as sexually secondary and the possible distinction between sex tissue as compared to phanerogamic sex. But let us leave to one side what may be involved in this. Let us note that what analytic experience designates is very precisely that at this level, there is no signifying coupling. It is at the point that, in the theory, although active-passive, voyeur-seen, etc oppositions are made, no opposition designating male-female has ever been promoted as fundamental.

The important thing, and the important thing that is in a way preliminary to the question that is raised of what is involved, in the

signifying system, of the function described as the phallus, in so far as it is what is effectively found to intervene, and in a way which it is of course never in any case anything but a third function. It represents either what is first defined as what is lacking, namely, grounding the type of castration as establishing that of the woman, or what on the contrary, on the side of the male, is indicated in a way that is so problematic, what one could call the enigma of absolute enjoyment. In any case, it is not a matter here of correlative reference points, of distinctive reference points. One and the same reference point dominates the whole register of what is involved in the relation of being sexed. This privileged signifier, I want to mark here, justifies (264) in a long construction, which was made in close contact with the analysis articulated of what has been written, from what remains as a testament of our experience of neurotics, I was able to qualify as *missing signifier*? The question is important because if assuredly for what is involved in the articulation of the function of the subject, you clearly see that, however far the articulation of knowledge may be pushed, the subject shows the flaw there. To say that the phallus is the missing signifier at the level that I was able to state it, at the point of my discourse when I risked, let us say, first putting it forward, I believe that the context was not yet sufficiently articulated for me to be able to say what I am now specifying.

Let us start again, and this is the interest of our reference today, of starting from the trace. Let us start from this supporting point and let us remember the Arab proverb that, in my *Ecrits*, I quoted somewhere a long time ago. There are four things (I no longer know which, I must say that I forgot the fourth or that I am not trying to remember it immediately) that leave no trace, the one that I evoked at this turning point. The foot of the gazelle on the rock, there is also the fish in the

water and what interests us more, the man in the woman, says the proverb, does not leave a trace. This can on occasion be objected to in the following form, whose importance one knows in the phantasies of neurotics, a little sickness from time to time. But precisely this is what is instructive. The role of venereal diseases is not at all random in the structure. We cannot start from any trace to ground the signifier of the sexual relationship. Everything is reduced to this signifier the phallus, precisely, which is not in the system of the subject since it is not the subject that it represents but, as one might say, sexual enjoyment *qua* outside the system, namely, absolute. Sexual enjoyment in so far as it has this privilege as compared to all the others, the fact is that something in the pleasure principle, that we know constitutes a barrier to enjoyment, the fact is that something in the pleasure principle allows it access all the same. You must admit that even from Freud's pen, we read that this is enjoyment *par excellence*, and what is more it is true. But that it should be read from the pen of a savant who merits so much this title as our Freud does, this has all the same something that may make us dream. But it is not in this system of the subject, there is no subject of sexual enjoyment.

And these remarks have no other interest than to allow us to specify the sense of the phallus as missing signifier. It is the signifier outside the system, and in a word the conventional one to designate what is involved in sexual enjoyment as radically foreclosed. If I spoke about foreclosure quite rightly to designate certain effects of the symbolic relation, it is here that it must be seen, that the point must be designated where it cannot be revised. And if I add that everything that is repressed in the symbolic reappears in the real, it is indeed (265) because enjoyment is quite real. The fact is that in the system of the subject, it is nowhere symbolised, nor can it be symbolised. This

indeed is why there is necessarily, in Freud's remarks, this enormity that seems to disturb no one, except a few people: a myth that strictly does not resemble any myth known to mythology. Old Kroeber and Levi-Strauss see very clearly that this does not form part of their universe and they say so, but it is exactly as if they had said nothing, since everybody continues to believe that the Oedipus complex is an acceptable myth. It is so, in effect, in a certain sense, but note that this means nothing other than the place where this enjoyment that I have just defined as absolute must be situated. The myth of the primordial father, is of the one who confuses in enjoyment all the women. The simple form of the myth says enough about it. It means that we do not know what enjoyment is at stake, is it his own or that of all the women? Except that feminine enjoyment has remained, as I have pointed out to you, also still at the state of an enigma in analytic theory.

What is meant then by this phallic function that seems, by not representing the subject, to mark nevertheless a point of his determination as a field limited by a relationship to what is structured as Other. It is by auscultating more closely, by coming back from these radical perspectives towards our experience, that we are immediately going to see how things are expressed. The turning point from which the birth of a neurosis emerges, is what? It is the positive intrusion of an auto-erotic enjoyment that is perfectly typified in what are called the first sensations more or less linked to onanism, however you want to describe it, in the child. The important thing is that it is at this point, for the cases that fall under our jurisdiction, namely, those that generate a neurosis, it is at this precise point, at the very moment that this positivisation of erotic enjoyment is produced that correlatively there is also produced the positivation of the subject as

dependency, anaclitism I said the last time, on the desire of the Other. Here there is designated the entry point through which the structure of the subject becomes a drama. The whole experience that is going to confirm at what frontiers, at what junctions this drama is going to explode, deserves to be articulated. I think that I already sufficiently marked the last time the weight the o-object takes in it, not so much in so far as it is presentified but in demonstrating retroactively that it was what previously constituted the whole structure of the subject.

We are going to see at what other frontiers the drama breaks out. But here and now we know from the fall-out of these effects, that it is thanks to the positive relation, to the enjoyment described as sexual, but without, for all that, the sexual conjunction being in any way (266) assured, that something is designated as essential for the position of the subject. It is the desire to know. The decisive step taken by Freud about the relation of sexual curiosity to the whole order of knowledge, is the essential point of the psychoanalytic discovery. And it is from the connection between what is involved in o - namely, where the subject can rediscover his real essence as essentially lack of enjoyment, and nothing more, whatever representative he may be designated by subsequently - and the field of the Other, on the other hand, in so far as the knowledge that is at the horizon of this domain forbidden of its nature which is that of enjoyment is organised in it. With it the question of sexual enjoyment introduces this minimum of diplomatic relations that I would say are so difficult to sustain. It is in as far as something is produced that I called drama, that the significance of the Other *qua* structured and holed is something different to what we can metaphorically call the signifier that holes it, namely, the phallus. It is in so far as it is something different that we see what happens when the young subject has to respond to what is

produced by the intrusion of the sexual function into his subjective field.

I made great play, and those who attended still remember it, in connection with little Hans. Little Hans which is the exemplary observation of a first absolutely disorganised exploration, going around in circles, up to a certain point undirected, with nevertheless the imperialist direction of the reference to the father first who plays a role whose flaws I marked and the Freud does not dissimulate. But Freud himself is for his part also the final reference, that of a knowledge presumed to be absolute. I took care, as I said, to take up at length everything that is outlined in this disorder in order to show its different strata. But one of them is nothing other than the game that little Hans indulges in which is that of the confrontation of the big giraffe and the small giraffe. I was able to underline its importance by showing what the phobia reveals at its foundation. Namely, the impossibility of making the *hommelle*, namely, this phallic mother - which is the relationship that Hans expresses in the big giraffe - co-exist with, on the other hand, anything whatsoever that might reduce it. If he draws the little giraffe, it is clearly to show not that it is an image comparable to the other, but that it is a writing on a sheet of paper. And for that reason, he *zerwurzelt's* it, as it is put in the text, he crumples it up and sits on it.

The important thing here is not the imaginary or identificatory function of Hans to this complement of the mother, the phallus, which is fundamentally his great rival. It is that he makes this phallus pass over into the symbolic because it is there that it is going to have its efficacy, and everyone knows what the order of efficacy of phobias is. If there is one thing that is useful in political vocabulary, and it is not for

nothing at the joining of power and of knowledge, it is to launch into a corner of the world to which I already made an allusion earlier with language, that of the paper tiger. What is more of a paper tiger than a (267) phobia, since very often, the phobia is a phobia that a child has for the tigers that are in his album, tigers that are really paper. Only, if politicians have all the trouble in the world in persuading the masses to put paper tigers in their place, here the function, or more exactly the indication, to be given is exactly the opposite. It is to give all its importance to the fact that, to complete something, something that cannot be resolved at the level of the subject, at the level of intolerable anxiety, the subject has no other resource than to foment for himself the fear of a paper tiger. This all the same is what is instructive, because as well, of course, it is not a subject of the type that psychoanalysts imagine. Namely, the way it expresses itself, is a facility of style. He does all of that by arranging it as best he can. The paper tiger, at a moment, at the moment when what is at stake is precisely the person of little Hans, is entirely a symptom. At that moment, all by itself, the world, or at least its foundation, the *hommelle* before whom he is, all by herself is transformed into a paper tiger.

There is the closest link between the structure of the subject and the fact that the question is thus posed that the *hommelle*, is something that all of a sudden grimaces, is frightening. And whether it is a tiger or a smaller animal, a cat, this is of no importance, no analyst is deceived about its true function. If then we have been led, at the end, to see the importance of lack as regard the quite real object that the penis is in everything that determines what one can call a sexed relationship, it is because the path has been opened up for us by the neurotic, and by the castration complex, in so far as it effectively realises the place of lack in the field of the signifier. It is only the result of the discourse

through which we have to ward off the questions posed by the neurotic. It is only at the end of a psychoanalysis that it is necessary that what is and well and truly remains, as little Hans says, rooted, *angewachsen*, and thank God, one would wish it to be, at least for most, in a position to be put to use, it is necessary that on a certain plane it should have been *zerwurzelt*, that one should clearly show that it is only a symbol.

Hence, of course, what I already said was a problem at the end of the treatment of little Hans. If it is necessary, of course, that he like every neurotic should come at the end to the formula that to become a man I do not have the penis as a symbol, because that is the castration complex. But it must be observed that this can be cut in two ways. The "I do not have the penis" which is precisely what is meant by saying that the end of analysis, is the realisation of the castration complex. This, of course, rejects elsewhere the pure and simple function of the penis as it functions, namely, outside the symbolised register. But this could also be cut differently. Namely: "I do not have the penis as a symbol, it is not the penis that qualifies me as signifier of my virility", and this was not obtained from little Hans because this is (268) what passed through the mesh of the net. Little Hans who never stopped during all this time playing with little girls his role of the one who has it, preserves, as I well and truly made the reservation at one time, preserves in sexual relationships this something that puts in the foreground the penis as an imaginary function. Namely, that this is what defines him as virile. Namely, that however heterosexual he may show himself to be, he is very exactly at the same point that the homosexuals are at, I mean those that recognise themselves as such. Because one cannot extend the field of what structurally corresponds

properly to homosexuality too far into the field of the appearances of normal relations, when what is at stake are sexual relationships.

Hence the importance of the exploration and the statement of this joint that, between the imaginary and the symbolic, is at its correct place the function, or more exactly the aspects of the function that we define as castration complex. How this is further fed by the experience we have of the joint between the Other and enjoyment in other forms of neurosis, is what I will subsequently continue with.

Seminar 21: Wednesday 21 May 1969

(269) The system of nowhere (*nulle part*), one could say, is what we have to present. It is here indeed that the term utopia would finally take on its sense, but this time realised from the proper end, as I might say. The old “nullibiquity” to which, in the distant past, I had given again the lustre it deserves for having been invented by Bishop Wilkings, is nowhere. What is it? It is enjoyment. What analytic experience demonstrates, it must be said again, is that by a link to something that is nothing other than what permits the emergence of knowledge, enjoyment is excluded, the circle is closed. This exclusion is only stated from the system itself in so far as it is the symbolic. Now, it is through this that it is affirmed as real, the last real of the functioning of the system itself that nowhere excludes it. It has become everywhere again from this very exclusion which is the way through which it is realised. This indeed, as we know, is what our practice applies itself to unmasking, unveiling in what we have to deal with, in the symptom, unmasking this relation to enjoyment, our real, but in so far as it is excluded.

That is why we advance these three terms as a support: enjoyment in so far as it is excluded, the Other as locus where that is known, the o as

an effect of the fall that results - because that is what is at stake in the affair - that results from the fact that, in the operation of the signifier, it is nevertheless enjoyment that is aimed at. The signifier arises from the unspeakable relationship of this something that, by having received from somewhere, this means, the signifier, is stamped by it with a relation to this something that from there develops, takes shape as the Other. This link of the subject to the Other, an Other which has avatars, has not said its final word. This indeed is what we are grappling with. It is at the level of these terms that we have to situate this psychoanalysis which is, as I might say, from its origin the crude experience of them, which came to birth no doubt in an exceptional flash through Freud. Ever since, it has never ceased to be at the mercy of the different aspects presented to it, which are identical to those in whose network the subject it treats is caught.

I would like to start from something that is as close as possible. Listen, you can talk to me about morality as much as you want, analytic morality if you wish, or another one, it does not matter. Good. Here is an object that I have a preference for, a preference as an apparatus. It is a fountain pen that in its slenderness is as close as possible to a pen, a pen in the antique, antediluvian sense; there are only very few people (270) who use it. As such its content is very limited because as you see, its reservoir can fit in and end up by becoming reduced to something that can be held in the palm of your hand. Its reservoir contains very little. The result is that it is very difficult to fill, because osmotic effects are produced, which means that when one pours in a drop, the drop is just the same size as the entrance. It is therefore very inconvenient; and nevertheless I am fond of it. I have a very special preference for it, because it reproduces a certain type of pen with a feather, a real feather and in effect it dates, it dates from an epoch

when it really was a feather and not something rigid like it is now. Someone who knew that I was looking for one gave this pen to me. It was a present that had just been made very few minutes, or hours or days before, it does not matter, by someone who certainly made of it a homage of a rather precise order, that was in fact fetishistic. It was moreover an object that was distinguished by coming from the grandmother of the person who donated it to the person who gave it to me. That indeed is why it is not easy to find. There are very particular shops, it appears, in New York where they sell pens from the Belle Epoque. I got one as you see along a different path.

I have then a glimpse of the history of this object that, moreover, is close to my heart for its own sake, altogether independently of this history, because in truth I am not specially grateful to the person who gave it to me for having made this present. My relation to it is independent; it is certainly very close to what the o-object is for me. I have a glimpse of its history but, for every object, do you not see something from the way I have brought this one to life, that this question of its history is posed just as much as for any subject. How can one imagine that one knows this history, who can answer for it except by establishing this Other as the locus where it is known. And who does not see, if one opens up this dimension to him, that at least for some people, and, I would dare to say, for everyone, it exists. For some people it is altogether prevalent, but for everyone it forms a foundation. There is somewhere where everything that has happened is known. Once one begins to question oneself along this path, one recognises that the signifier of O as completed is implicit and that for the obsessional neurotic it is much more so than for the others. That is why, at the level of history, in so far as – that is why I took this angle – it is suggested not at all directly about the subject but moreover about

the fate of objects, it is along this path that we can see how mad is the presupposition of some locus or other where it is known. This is important because it is clear that “it is known, *ça se sait*” turns immediately into the interest the question takes on. There where it is known, in the neutral sense that we have introduced it, this is where the question is posed about whether it knows itself.

Reflexivity only emerges from consciousness by this detour that must (271) be verified, the fact is that where one supposes that it – everything - is known, does it know that it is known? If one questions oneself about what is involved in mathematical activity, it is a funny thing to note that the mathematician very specially is still just as incapable of saying anything about its foundation, except that he knows very well when he is doing mathematics. As far as telling you how he discerns it, up to the present, *mum’s the word*. He can say that this is not it, but what it is has not yet been found. We are putting forward a statement that perhaps may begin something along this path; to organise things, things that are said, in such a way that it knows itself, undoubtedly, at every instant, and that it can bear witness to it. As someone said to me quite recently, a mathematician with whom I was speaking about it, what characterises a mathematical statement is the freedom of its context. A theorem can be stated all by itself and be defended. It carries in itself this sufficient dose of overlapping itself that makes it free of the discourse that introduces it. The matter is to be looked at again closely. This aspect of difference to other discourses where every quotation risks being excessive with respect to what surrounds it, what is called context, is important to note. This substance of instantaneous “it knows itself” as such, is accompanied by the fact that it supposes that everything that is reached there is known, in the sense of “it overlaps itself”, it is known as a whole. Namely,

that what is revealing, is that the presuppositions of a discourse that aspires to be able to entirely overlap itself encounters limits. It encounters limits in the fact precisely that points exist in it that cannot be posited. The first image of them will moreover be given by the sequence of integers and by something that articulates that what is defined as being greater than any other one can precisely not be posited, I mean in an infinite series, as they say, of integers.

It is precisely because this number is excluded, and properly *qua* symbol – nowhere can there be written this number greater than any other – it is very precisely from this impossibility of writing it that the whole series of integers takes on its character, not of being a simple representation (*graphie*) of something that can be written, but of being something that is in the real. This very impossibility is what the real arises from. This mechanism is very precisely what allows it to be taken up again, at the level of the symbol, and to write under the heading of transfinite this very sign that cannot be posited in the series of integers, and to begin to question what can be done starting from this sign that has been posited as not able to be posited in the series of integers. And to notice that effectively this sign, a symbol taken up at the level of what constitutes the reality of the series of integers, allows a new symbolic treatment where the relations acceptable at the end of the series of integers can be taken up again. Not all but very certainly a part of them. And this is the progress that is being pursued by a (272) discourse that, knowing itself at every instant, is never found without this combination of limits with holes that is called infinity. Namely, not graspable until precisely it is, by being taken up into a different structure, reduced to this limit, the aporia in any case only being the introduction to a structure of the Other.

This is what is very clearly seen in set theory, into which one can for a certain time in effect advance innocently. It interests us in a particular way because after all, at the more radical level that we have to deal with, namely, the incidence of the signifier in repetition, in appearance there is no objection. There is no objection at first to the O being the entire inscription of all possible histories. Every signifier refers all the more to the Other in that it cannot refer to itself except as other. There is no obstacle then to the signifiers being divided up in a circular fashion, which, under this heading, allows it very easily to be stated that there is a set of everything that of itself is not identified to itself. By going around in a circle, it is perfectly conceivable that everything is organised, even the catalogue of all the catalogues that do not contain themselves. It is perfectly admissible on this single condition that one knows, and it is certain, that no catalogue contains itself, except by its title. This does not prevent the set of all the catalogues having this closed character that each catalogue, in so far as it does not contain itself, can always be inscribed in another that it contains itself. The only thing excluded, if we trace out the network of these things, is the sketch that would be written in this way. The one that admits from one point to another of any network whatsoever from an oriented network, that excludes, if b refers to a certain number of other points, d, e, f that excludes the fact that b refers to itself. It is enough on this occasion for b to refer to c, and that c itself refers to b for there no longer to be any obstacle to the correlative subsistence of b and c and that a set includes them. [e?]

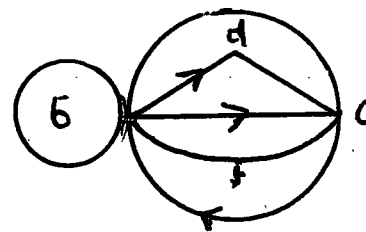

If something questions us, it comes precisely from analytic experience as locating somewhere this point at the infinity of everything that is organised in the order of signifying combinations. This point at infinity being irreducible in so far as it concerns a certain enjoyment, that has

remained problematic, and that for us sets up the question of enjoyment under an aspect that is no longer external to the system of knowledge. It is around this signifier of enjoyment, this signifier excluded in so far as it is the one that we promote under the term of (273) phallic signifier, it is around this that there is organised all the biographies to which analytic literature tends to reduce what is involved in neurosis.

It is not because we can overlap with as complete a homology as possible what are called the interpersonal relations of what we call an adult – an adult, it must be said, fundamentally adulterated. Because what we find throughout these relations, we seek in the second biography that we say is original, which is that of his infantile relations. And there, at the end of a certain familiarisation by the analyst, we take as accepted the relations of tension that are established with respect to a certain number of terms, the father, the mother, the birth of a brother or a little sister that we consider as primitive. But that, of course, only takes on this sense, only takes on this weight by reason of the place that they hold in my articulation. Like for example – there will perhaps be more developed ones, I hope so – but like in fact the one I am articulating for you with respect to knowledge, enjoyment and a certain object in so far as primordially it is with respect to them that there are going to be situated all these primordial relations. In these it is not enough to bring up simple homology by going into the past with whoever comes to tell us about his present day relations. Whether we want it or not, whether we know it or not, we bring into play its weight, its presence and its agency in the whole way in which we understand this second primary biography, described as infantile. This is only there, quite often, to mask the question from us, the one on which we for our part should really question ourselves, I

mean we analysts. Namely, what determines in this way the infantile biography whose mainspring is quite obviously always only the way in which there are presented what we call desires in the father, in the mother. These consequently stimulate us to explore not simply the history but the style of presence in which each of these three terms, knowledge, enjoyment and *o*-object were effectively presented to the subject. This is what ensures, and here there lies, what we call improperly the choice of neurosis, indeed the choice between psychosis and neurosis. There was no choice, the choice was already made in what is presented to the subject but is only perceptible, locatable in function of three terms as we have just tried here to bring them out.

This matter has more than one implication. It has a historical aspect. Who does not see that if we must posit what psychoanalysis signifies in history, and if certain choices are also offered to it, it is in as far as we live in a time when the dimension of community, the relationships of knowledge to enjoyment, are not the same as they were, for example, in ancient times. And that, undoubtedly, we cannot take our position as being comparable, for example, to that of the Epicureans or (274) any other such school. There was a certain position of withdrawal with respect to enjoyment that was possible for them, in a way that was rather innocent. At a time when, through the bringing into play of what we call capitalism, a certain position includes all of us in relation to enjoyment in a characteristic fashion, as one might say, by the purity of its framework. What is called the exploitation of the worker does not consist, very precisely, in the fact that enjoyment is excluded from work. At the same time, it does not give it all its real in the same way as we have evoked earlier the effect of the point at infinity. It is through this that there arises this sort of *aporia* that

suggests the new sense with regard to the dominion of society, the new sense - without precedent in the ancient context - that the word revolution takes on. And this is why we have our word to say in it. To recall that this term is, as Marx perfectly well saw, and this is why he articulates the only thing that has been found efficacious up to the present, it is the close solidarity of this term called revolution with the very system that carries it, which is the capitalist system.

That on this we have something that can perhaps offer the opening through a series of examples of what can be involved in a joint where the circle will open out, this is the interest of psychoanalysis. I mean its interest in history. It is moreover what it must totally fail at. Because to take things at the level of biography, what we see being offered at the turning point that the moment of the outbreak of neurosis constitutes biographically is the choice that is offered. It is offered in a way that is all the more insistent in that it is what is determining in this turning point. The choice between what is presentified, namely, the approach to this point of impossibility, of this point at infinity, that is always introduced by the approach of sexual contact. And the correlative aspect that is announced from the fact that at the level of the subject, by reason of the premature moment – but how would it not always be premature with regard to impossibility – by reason of the premature moment that it comes into operation in childhood, what projects, masks, diverts this impossibility by having to be exercised in terms of inadequacy, of being only *qua* living being, a living being reduced to his own forces, necessarily not up to it. The alibi taken for impossibility in inadequacy, is moreover the slope that what I called the direction of psychoanalysis may take. And this, after all, is not humanly speaking something in which in effect we cannot fail to feel ourselves the ministers of a help that on one or other point, with

respect to one or other person, may be the occasion of a benefit. Nevertheless, this is not what justifies psychoanalysis. It is not from there that it emerged. It is not there that it has its sense and for a simple reason, which is that it is not this that the neurotic bears witness to. Because what the neurotic testifies to us, if we want to hear what he (275) is telling us through all his symptoms, is that where his discourse is placed it is clear that what he is looking for is something different than to be equal to the question he poses.

The neurotic, whether it is a hysteric or an obsessional that is at stake – we will subsequently make the link between the two aspects and this object that we have brought forward in the efficacy of phobia – the neurotic puts in question what is involved in the truth of knowledge. And very precisely in the fact that he/it is attached to enjoyment. And in re-posing the question, is he right? Yes certainly, because we know that it is only from this dependency that knowledge has its original status and that in its development, it articulates its distance. Is he right? His discourse is certainly dependent on what is at stake in the truth of knowledge. But as I already articulated before you, it is not at all because this discourse relates to this truth, that it is true. The consistency of the suspension of knowledge on the prohibition of enjoyment does not render any more legible in what, at a certain level, exposes this constitutive knot, and moreover why would it also not express, in the final term, a certain form of aporia? If I said it earlier, in what is presented as a position taken up in the impasses that are formulated as the law of the Other, when it is the sexual that is at stake, I would say that in the final term, after having sifted as much as I could the angle from which the obsessional and the hysteric are distinguished, the best formula that I could give proceeds precisely from what is offered in nature, naturally, as a solution of the impasse

of this law of the Other. For the man who has to fulfill this identification to this function described as that of the symbolic father, the only one that is satisfying - and this is why the position of virile enjoyment in what is involved in sexual conjunction is mythical - for the man, what is offered at the level of the natural is very precisely what is called knowing how to be the master. And, in effect, this was, this probably still is, this was and this still remains sufficiently within someone's reach.

I would say that the obsessional is the one who refuses to take himself as master because, with respect to what is at stake - the truth of knowledge - what is important for him, is the relationship of this knowledge to enjoyment. And what he knows of this knowledge, is that it has nothing, nothing more of what remains from the first incidence of its interdiction, namely, the o-object. Any enjoyment is only thinkable for him as a treaty with the Other as whole always imagined by him as fundamental, with whom he deals. Enjoyment for him is only authorised by a payment, by an always renewed payment, into the insatiable jar of the Danaï, into this something that is never finished and that makes of the modalities of the debt the ceremonial where alone he encounters his enjoyment.

Inversely, on the opposite side, the hysteric, and it is not for nothing that there is met this form of answer to the impasses of enjoyment, at the opposite side, the hysteric - and it is precisely because of this that this style is more especially found among women - the hysteric is (276) characterised by not taking herself for the woman. Because in this impasse, in this aporia, just as naturally as for the master, things are offered just as plainly to the woman to fulfill a role in sexual conjunction in which naturally she has a rather large part. What the

hysteric, they say, represses, but what in reality she promotes, is this point at infinity of enjoyment as absolute. She promotes castration at the level of this name of the symbolic father in the place of whom she posits herself, or as wanting to be, in the final moment, his enjoyment. And it is because this enjoyment cannot be reached that she refuses any other which, for her, would only have this diminished character of only being, which moreover is true, something external, by only being at the level of sufficiency or insufficiency, with respect to the absolute relationship that it is a matter of positing.

Read and re-read the observations of hysterics in the light of these terms, and you will see in a completely different way from that of anecdote, from a biographical going around in circles, that the transference by repeating no doubt makes more manageable, but only tempers, to understand the source of what comes to us as an opening, as a gap, by whatever means moreover we try to calm it. Is it not essential to spot this source from which it arises and which is nothing other than the way in which the neurotic questions again this frontier that nothing can in fact suture, the one that is opened up between knowledge and enjoyment.

If, in the articulation that I gave of the 1 and the 0, which is certainly not promoted here by chance or in an out of date way, which is nothing other, as I told you, than the way in which, in a mathematical model there is inscribed – and there is no reason to be surprised at it because it is the first thing that you have to encounter – there is inscribed in a series what is connected to the simple repetition of the 1, on the single condition that we inscribe its relation in the form of an addition. After two 1's, a 2, and to continue indefinitely, the last 1 joined to the 2, a 3, 5, and afterwards an 8 and after that a 13, and so on. It is this, as I told

you, that by the proportion that it generates, that gets tighter and tighter as the numbers grow, strictly defines the function of o . The series has this property of exposing by being taken up in the opposite sense, by proceeding by subtraction, of culminating at a limit in the negative sense. Which, marked by this proportion of o , will continue to diminish and come to what one makes of it, in this direction, the sum, at a perfectly well defined limit that, then, taken up again is a starting point.

What the hysteric does can be inscribed in this direction, namely, that he or she subtracts this o as such from the absolute 1 of the Other, by questioning it. By questioning whether it delivers or not this final 1, that is in a way her assurance. In this process, it is easy with the help of the model that I have just recalled, to demonstrate that at best all her effort, I mean the effort of the hysteric after having put in question this (277) o , will be nothing more than to find herself as such, strictly equal to this o and to nothing else. Such here is the drama that is expressed, by being transposed from the level where it is, where it is stated in a perfectly correct way in another, is expressed by the irreducible gap of a castration that has been realised.

There are other ways out of the impasse opened up by the hysteric by the fact that it is resolved at the level of statements, at this level that I characterised by the label "*famil*", by the encounter with castration. But at the other level, at that of stating, at that which promotes the relation between enjoyment and knowledge, who does not know that illustrious historical examples allow it to be grasped that at the level of a knowledge that is supposed to be a knowledge overlapping itself by an experienced knowledge of the relation as it is presented, of the sexual relation as it is only grasped from the apprehension of this point

at infinity which is impasse and aporia, certainly, but which is also a limit, the solution can be found of a subjective equilibrium, on this single condition that the correct tribute is paid from the edifice of a knowledge.

For the obsessional, everyone knows that it is the same; everyone knows that a whole sector depends on the productivity of the obsessional; even those most blind, most closed to historical reality have glimpsed his contribution to what is called thinking. Is this not also here what expresses his limit, what necessitates it being exorcised to the highest degree? It is to here that Freud takes the question when he speaks about the relationships of obsessional ritual to religion. Assuredly all religion is not exhausted in these practices. And this indeed is what is anxiety-provoking in Pascal's wager. It makes us see that by taking things even at the level of the promise, by proving oneself to be a partisan of the God of Abraham, of Isaac and of Jacob, and by rejecting the Other, by rejecting him to the point of saying that one does not know whether he is, nor of course much more what he is. It is nevertheless him, at the level of whether he is or not, of odds or evens, that he questions in the wager, because he is caught up, given his epoch, in this questioning of knowledge.

It is at this point that I will leave you today.

Seminar 22: Wednesday 4 June 1969

(279) There are fewer people standing. For their sakes I am not sorry, but if this means that the audience is becoming depleted, I am sorry since moreover it is necessarily – this is my style – in the final meetings that I will say the most interesting things! This reminds me that last year, of my own volition and for reasons that I will not repudiate, I suspended what I had to say at the beginning of a memorable month of May. However legitimate these reasons may have been, it nevertheless remains that what I said about the psychoanalytic act remains truncated. Given what was at stake, namely, precisely the psychoanalytic act, that no one had even dreamt of naming as such before me, which is an altogether precise sign that people had not even posed a question about it. Since otherwise it was the simplest way to name it, once people realised that in psychoanalysis there was somewhere an act, we must believe that this truth had remained veiled.

I do not think that it is by chance that what I had to state that year about the act found itself then, as I have just said, truncated. There is a relationship, a relationship that is naturally not one of causation, between this shirking of psychoanalysts about the subject of what is involved in an act – specifically the psychoanalytic act – and these

events. But there is a relationship all the same between what causes events and the field in which the psychoanalytic act is inserted. So that up to the present one can say that it is no doubt because of some lack of interest in this act that psychoanalysts have not shown themselves to be very prepared or available to even give a hint of a grasp, even a superficial one, of these events. Naturally, it is only accidental that, in the other sense, the events interrupted what I might have had to say about the act, but all the same it does not fail either to represent something that, for my part, I consider to be a certain rendezvous. A rendezvous that I do not regret because it spared me, on the subject of the psychoanalytic act, in short, from coming to say what should not be said.

There you are. All the same, we find ourselves, after what I put forward the last time, brought back to something that is not far from this field. Because what is at stake, as I announced last year, is indeed an act in so far as it is in relationship with what I called, stated, (280) proposed, as being the o-object. Let it be quite clear that, since it is in my title this year and this is what is at stake in my discourse, this is something that ought to find its most formal expression in these final meetings. And, at least for those who are *au fait* with what I ended on the last time, it seems to me that it is no harm to recall – I advanced it in terms of Pascal's wager – that it is at least the path that I chose this year to introduce it. To introduce it as being in the field of the Other, as defining a certain game (*jeu*), precisely the stake (*enjeu*), with the play on words that I make about this term *en-je*.

It may appear curious that a position that, in this respect, is not ambiguous, that is certainly not a position of religious apologetics, should introduce this element of the wager. And of a wager that finds

itself formulated as responding to a certain partner. A partner who is taken there, as one might say, at his word, at the word of a statement that is attributed to him, under a heading, my God, that is generally accepted, the promise of eternal life, for every believer who follows God's commandments. This is held to be something accepted, at least in the field of what constitutes with respect to him, this God, the largest religious reference, namely, the Church.

It is not out of season to start from there, because it has a quite lively relationship with what is at stake as permanent in our structures, and in structures that go much further than structures that could be qualified as mental structures. Structures in so far as they are defined by common discourse, by language, obviously go much further than what can be reduced to the function of mentality. As I very often insisted, this enfolds us from every side, and in things that, at first sight, do not seem to have an obvious relationship. So that this structure which is the one that I am aiming at to start again from today, the original structure, the one that I called that of an Other, to show where, through the incidence of psychoanalysis, it is going, to reveal a quite different other, namely the *o*. This Other – let there be no doubt about it within our horizon - this Other which is precisely the God of the philosophers, is not so easy to eliminate as people believe. Since in reality it undoubtedly remains stable at the horizon, in any case, of all our thoughts. It is obviously not unrelated to the fact that there is the God of Abraham, of Isaac and of Jacob – you will see it, I will come back to it – and this will be my subject today, the structure of this Other. Because it is very necessary carefully to establish what is to be designated there. It is no less timely, at the outset, to indicate that what constitutes for us, in a certain horizon of structure, in so far as it is determined by common discourse, it is clear that it is no harm to recall

that, if this structure, that of the big Other, is for us in a certain field, the very one Freud designated as civilisation, namely, Western civilisation. The presence of the other God, the one that speaks, (281) namely, the God of the Jews, the God of Abraham, Isaac and of Jacob, is not for nothing in the maintenance of this Other.

This is not simply because the God of the philosophers, this big Other is One. What distinguishes the God of the Jews, the one designated as being at the origin of monotheism, is not some development that the One was subsequently able to make. It is not that he posits himself as being himself One that characterises him. The God of the burning bush, the God of Sinai did not say that he was the only God. This deserves to be recalled. He says: "I am what I am". That has a completely different meaning. That does not mean that he is the only one. That means that there is none other at the same time as him where he is. And in truth, if you look at it closely in the text of the Bible, you will see that this is what is at stake. There where he is, in his field, namely in the Holy Land, there is no question of obeying anyone but him. But nowhere is the presence of others denied, where he is not, where it is not his land. And if you look closely at it, it is only when there is an encroachment of the honours rendered to others where there reigns alone the one who said "I am what I am", that chastisements rain down. This might seem in the eyes of some people to have only a historic interest. But I am laying my cards on the table. It is only coming back to what I stated at first, which is that this god that is in question, designates himself by the fact that he speaks. This is what makes it legitimate that whatever distortion was undergone later by this word, because it is not sure that they are saying quite the same thing in the Catholic Apostolic Roman Church, in any case the God that is defined by his relationship to the word, is a God that speaks. This

indeed is why the prophets, as such, are pre-eminent in the Jewish tradition. In other words, the dimension of Revelation as such, namely, of the word as carrying the truth, was never highlighted as much outside this tradition. Elsewhere the place of the Truth is filled, it is necessary for it to be covered, on occasion by myths for example. It is not so by prophesy except in a quite local way that is called oracular but which has a completely different sense to that of the prophetic tradition.

A rather heavy introduction, but all the same necessitated by the reminder of certain quite massive reliefs to be maintained in order to properly understand what is at stake when we put forward, that with regard to the field of truth that interests us as such in an outstanding way, even if we do not identify it to revealed formulae, with respect to this field of the truth, knowledge is elsewhere. That indeed is why, once the dimension of Revelation is introduced, there is introduced at the same time the dimension traditional in our culture that one must not believe extinguished because we are in our time, the dimension of what is improperly called the double truth. That means the distinction between truth and knowledge.

(282) So then what interests us, because this is what psychoanalysis revealed, is what is produced in knowledge. What is produced in knowledge, but was not suspected before psychoanalysis, is the object in so far as analysis articulates it for what it is. Namely, the cause of desire, of the division of the subject, of what introduces into the subject as such what the *cogito* masks. Namely, that alongside this "to be, à être" that it thinks it can reassure itself with, it is essentially and from the beginning lack. It is here that I remind you that I am taking up again the plan through which I believed last year I should

introduce the paradox of the psychoanalytic act, which is that the psychoanalytic act is presented as a stimulus to knowledge. It implies, in the rule that is given to the psychoanalysand, it implies this, since you can say anything you want. And God knows what this may represent at first in terms of being senseless, if we were taken at our word, if people really set about saying - and if this had a sense for those that we introduce to this practice - everything that passed through their heads. If everything that passed through their heads really meant anything at all, where would we end up? If we can have faith in those that we introduce into this enterprise, it is very exactly because of the fact that, even if the person that we introduce into this practice is not capable of saying it, is nevertheless there. Namely, that what is implicit, is that whatever you may say, there is the Other, the Other who knows what it means.

The God of philosophers, however he may have been throughout history attached to the train of the God that speaks, is certainly not foreign to him of course. It was not illegitimate to make of this God of the philosophers the base, the throne, the support, the seat of the one who spoke. That the seat remains even when the other has risen to go, at least for some, the seat remains of this Other, of this Other in so far as he situates this unifying, unified field that has a name for those who think. Let us call it, if you wish, the principle of sufficient reason. That you may not suspect, I mean at least a part of you, a part that I suppose, after all - I do not know whether it exists - you are perhaps all capable of perceiving that you are sustained by the principle of sufficient reason. If you do not perceive it, it is exactly the same thing. You are in the field where the principle of sufficient reason sustains everything. And it would certainly not be easy to make you conceive of what is happening where things are otherwise. What is perfectly

conceivable from the moment that it is put to you, when it is stated as being, for example, at the horizon of what renders psychoanalytic experience possible, namely, that if there is not a sufficient reason for whatever you may say, in looking no further than to say what passes through your head, there will always be a sufficient reason for it. And that is enough to put on the horizon this big Other, the one who knows.

The thing is in any case quite clear in the privileged subjects of this (283) experience, namely, the neurotics. The neurotic seeks to know. We are going to see more closely why, but he seeks to know. And at the beginning of analytic experience, we have no trouble in encouraging him, in short to have faith in this Other as a locus where knowledge is established, in the *subject supposed to know*.

It is then as an intervention on the subject of what, at the most basic level, at the most basic level there is, is already articulated as knowledge, that we intervene by an interpretation that is distinguished from what supports the term interpretation everywhere else. Everywhere else an interpretation, that for example of any logical system whatsoever, is to give a system of lesser import that, as they say, illustrates, illustrates it in a way that is more accessible by the fact that it is of lesser import. We remain at the superimposition of articulations of knowledge. Analytic interpretation is distinguished by the fact that, in what is articulated here and now as knowledge, however primitive it may be, what it aims at, is an effect, an effect of knowledge by being articulated there and that it makes tangible under the heading of its truth.

Its truth, as we have said, is on the side of desire, namely, of the division of the subject. And to go straight to it, because naturally we

cannot go over the whole path here and what I have to say today is something different to be gone through, which is that the truth that is at stake is summarised as follows. That the Freudian thing, namely, this truth – the Freudian thing, this truth is the same thing – has the property of being asexual, contrary to what is said, namely, that Freudianism is pansexual. Only since the living being who is this being through whom a truth is conveyed has a sexual function and position, there results something from it, something that I tried to articulate for you two years ago now and not simply one. Namely, that there is not, in the precise sense of the word relationship, in the sense where sexual relationship is would be a relation that is logically definable, there is precisely none. What could be called sexual relationship is missing, namely, a relation definable as such between the sign of the male and that of the female. Sexual relationship, what is usually called by this name, can only be made by an act. This is what allowed me to put forward these two terms that there is no sexual act in the sense that this act is supposed to be that of a correct relationship, and that inversely, there is only the sexual act, in the sense that there is only the act to make the relationship.

In what psychoanalysis reveals to us, the fact is that the dimension of the act, of the sexual act in any case, but at the same time of all acts, what has been obvious for a long time, is that its proper dimension is failure. That is why at the heart of the sexual relationship, in psychoanalysis, there is something called castration. I spoke to you earlier about what is produced in knowledge. Necessarily, of course, you did not pay much attention to it. I should have said, what knowledge produces. I was not able to say it in order not to go too (284) quickly. Because in truth, for that to have a sense, it is necessary to come back to it more closely and to denote here the relief of this

dimension that is articulated as properly speaking production. This dimension that only a certain process of technical progress has allowed us to discern, to distinguish as being the fruit of work.

But is it so simple? Is it not apparent that in order for production as such to be distinguished from what was always *poiesis*, fabrication, work, the level of the potter, it is necessary that there should be made autonomous as such what is very well distinguished in capitalism, namely, the means of production. Since it is around this that everything turns, namely, who disposes of these means. It is by such a homology that the function of knowledge and what its production is will take on its relief. The production of knowledge *qua* knowledge is distinguished by being a means of production and not simply work of the truth. What knowledge produces, is what I designate under the name of *o*-object. And this *o* is what comes to be substituted for the gap that is designated in the impasse of the sexual relationship. This is what is going to duplicate the division of the subject by giving him what was not graspable up to then in any way, because what is proper to castration, is that nothing can properly speaking be stated, because the cause is absent. In its place there comes the *o*-object as cause substituted for what is radically involved in the flaw of the subject.

And what I told you last year, after having defined the function of the *o*-object in this way the previous year, is that the psychoanalyst is the one that by this incitement to knowledge even though he does not know all that much about it, and simply by having this path, this means, this device, this analytic rule, finds himself taking on the charge of what is truly the support of this *subject supposed to know*. And I told you on every tone of the scale that the problem of our epoch, of the state of psychoanalysis, is only itself to be taken as one of

the symptoms. The fact is that it is certain that this *subject supposed to know*, this Other, this unique locus where knowledge is supposed to connect up, does not exist. Nothing indicates that the Other is One, that it is not like the uniquely signifiable subject of the signifier of a particular topology that is summarised by what is involved in the o-object.

How can the psychoanalyst then, and this is where I accentuated the enigma and the paradox of the psychoanalytic act, the psychoanalyst in so far as he induces, as he incites the subject, the neurotic on this occasion, onto the path where he invites him to meet the *subject supposed to know*, how can the psychoanalyst, if it is true that he knows what a psychoanalysis is, how can he proceed to this act. Because he knows what is involved about what, at the end of the operation and with his very in-self (*en-soi*) he the analyst is going to represent the evacuation of the o-object. From this incitement to knowledge that ought to lead to the truth and that represents the gap in it, he falls by becoming himself the rejected fiction.

(285) I put forward here the word fiction. As you know, I have for a long time articulated that the truth has the structure of fiction. Is the o-object to be taken as simply marking this subject of the truth as division, or ought we as it seems give it more substance? Do you not sense there where we find ourselves at this crucial point, the one already properly marked in Aristotle's logic and that justifies the ambiguity of substance and subject. Of *hupokeimenon* in as much as it is logically nothing else properly speaking than what mathematical logic was afterwards able to isolate in the function of the variable, namely, what can only be designated by a predicative proposition. The ambiguity is maintained right through Aristotle's text not without there

being distinguished like a tress the function perfectly isolated by him of *hupokeimenon* and that of *ousia*. Honestly, it would be much better to translate it by being or by “*étance*”, by Heidegger’s *Wesen* on this occasion, than by this word that only conveys this aforesaid ambiguity of *substantia*, substance. It is indeed there that we find ourselves brought when we try to articulate what is involved in the function of the o-object.

It is around the enigma, the questioning that remains here about an act that cannot be initiated for the very one that inaugurates it except by a veiling of what would be for it, I mean the one that inaugurates this act and specifically the psychoanalyst, its term. And not simply its term but properly speaking its end, in as much as it is the term that determines retroactively the sense of the whole process, is properly its final cause, which does not deserve any derision because everything that belongs to the field of structure is unthinkable without a final cause. The only thing that deserves derision in terms described as finalistic, is that the end is of the slightest use.

Does the analyst know or not what he is doing in the psychoanalytic act? This is the precise term where there came to a halt in the previous year suspended by the eventful encounter with which I introduced my remarks today. As I told you, this was what dispensed me, at the horizon of such a difficult knot, so rigorously questioned by a putting in question of what is involved in the psychoanalytic act, dispensed me from the undoubtedly embarrassing resonances around which, nevertheless, can be questioned what is involved both in the theory and in the psychoanalytic institution.

Before indicating perhaps a little more about it, let us clearly recall what results from this way of posing between knowledge and truth and in the proper field of a production as regards which in short you see, it is the psychoanalyst as such that himself incarnates it. It is in terms of this production, it is in these terms that there ought to be situated the question, for example, of what is involved in transference. What need is there for everything that we designate as transference to be (286) interpreted in analysis in terms of repetition, except by those analysts who are absolutely astray in this network as I articulated it. What need is there to put in question what is objective in it and to claim that transference is a retreat before something or other that is supposed to be what is really operating in analysis. Since it is a situation that only takes its support from the structure, nothing can be stated within as discourse of the analyst that is not of the order of what the structure commands, and which then can grasp nothing except the order of repetition. The question is not of knowing here whether repetition is a dominant category or not in the story. It is that in a situation designed to question what is involved in what presents itself starting from the structure, nothing of the story is organised except from repetition. It is a matter, I repeat, of what can be said at the level of this putting to the test of the effects of knowledge. So that it is not correct to say that transference isolates in itself the effects of repetition. Transference is defined from the relationship to the *subject supposed to know* in so far as it is structural and linked to the locus of the Other, as the locus as such where knowledge is articulated in an illusory way as One. And that by questioning in this way the functioning of whoever seeks to know, it is necessary for everything that is articulated to be articulated in terms of repetition.

To whom are we indebted for such an experience? It is clear that it would never have been established if there were not the neurotic who needs to know the truth. Only those that the truth makes uncomfortable. That is the definition of the neurotic. This we are going to have to circumscribe more closely. And there again, before leaving this field, and with good reason, where I have not looped the loop, I want, in something that with respect to what I outlined may pass for a parenthesis, to highlight all the same a final one of these reference points with which I try to punctuate in a correct way this field in so far as we operate in it. If this is how it is, as I have reminded you, in a way accepted as partial, we ought to admit that the only thing that can be interpreted in analysis is repetition, and this is taken to be transference.

On the other hand, it is important to punctuate that this end that I designate as the capture of the analyst, of the analyst in himself in drilling for *o*, is precisely what constitutes the uninterpretable. That in a word, in analysis, the uninterpretable, is the presence of the analyst, and that is why to interpret him as has been seen, as has even been printed, is properly to open the door to what is called this place, namely, acting out. I recalled it in my seminar on the act, that then of last year and in connection with the myth of Oedipus. Namely, the distinction to be made between the heroic staging that serves as a mythical reference for our analytic practice, and what is articulated behind it, in terms of a knot of enjoyment at the origin of all knowledge. It is the psychoanalyst who is at the place, certainly, of (287) what was played out on the tragic stage and it is this that gives its sense to the psychoanalytic act. And on the other hand, it is striking that he renounces there, that all he does is to be at the place of the actor, in so far as one actor is enough just by himself to hold the stage

of tragedy. This division between the spectator and chorus in which there is modelled and is modulated the division of the subject in the traditional play, I recalled it last year, to designate what is involved exactly in the place of the analyst. Another paradox of the psychoanalytic act, this actor who is effaced, rejoining earlier what I said about him evacuating the o-object. If the *passage à l'acte* is in the rule of analysis what the person who enters into it is asked to avoid, it is precisely to privilege this place of *acting out* that the analyst just by himself takes and keeps charge of. To keep quiet, to see nothing, to hear nothing, who does not remember that these are the terms in which a wisdom that is not ours indicates the path to those who want the truth. Is there not something strange on condition that one recognises the sense of these commandments to see there an analogy in the position of the analyst? But with this singular fruit that gives it its context. Because he is isolated from it by keeping quiet, the voice that is the kernel of what, by being said, creates speech. By seeing nothing, which is very often only too well observed by the analyst, isolating the look that is the knot tightened on the sack of everything that is seen at least. And finally to hear nothing of these two demands into which desire has slipped, of these two demands that summon him, these two demands that block him from the function of the breast or indeed of excrement.

What reality is there to push him to fulfill this function? What desire, what satisfaction can the analyst encounter there? I do not intend to designate this right away even if before leaving you I should say something more about it. It is appropriate here to throw into relief the dimension of *scapegoat*, a theme cherished by Frazer. We know that its origin is properly speaking Semitic. The scapegoat, the one who takes on himself this o-object, the one who ensures that forever, the

subject can be reprieved from it. The one that ensures that the fruit of a terminated analysis, I was able last year to designate as a truth of which the subject is henceforth incurable, precisely because one of the terms of it have been evacuated. How can it not be seen that it is from there that there is explained the singular position that, in the social world this community of psychoanalysts occupies, protected by an international association for the protection of scapegoats! The scapegoat escapes by forming a group, and better still by degrees. It is true that it is difficult to conceive of a society of scapegoats. So then you make sergeant majors out of some scapegoats. And from the scapegoats who are only waiting in the antechamber to become so. Curious!

This facile derision would have no other reason for existing if, in the text that I have just received of an upcoming congress that will have the cheek to be held at Rome, there were not already texts, I mean (288) already published exemplary ones. Because it is not because people do not know Lacan's discourse that they do not find themselves face to face with the difficulties that I have just articulated here, and particularly what is involved in transference. When people struggle to define what is non-transferential in the analytic situation, some statements have to be brought out that are the confession, properly speaking, of the fact that nothing is understood about it. Nothing is understood about it because people do not have the key. And they do not have the key because they do not go looking for it where I stated it! In the same way, they invent a term called the *self*, and I must say that it would be no harm for someone who has some curiosity to see how this can both be justified and be resolved in a discourse like the one that I have articulated today. If I have the time at our next meetings, I will say more about it then. Likewise the error and properly speaking

the ineptitude of what is put forward on the subject of what is involved in psychoanalytic treatment of psychosis, and the radical failure marked in it to situate precisely psychosis in a psychopathology that is of an analytic order, comes from the same source.

Undoubtedly, if I indicated that I could have articulated something different, something from which I declared I was happily dispensed, about the subject of the psychoanalytic act, it is in the horizon of what is involved in the masochist that this articulation should be posed. And assuredly, of course, not in order to confuse them, psychoanalytic and masochistic practice. But it would be instructive and, in a way opened up, already indicated by what we were able to say, by what is literally displayed in masochistic practice, namely, the conjunction of the perverse subject with the o-object properly speaking. In a certain way, one can say that as long as he wants it, the masochist is the true master. He is the master of the true game. He can fail at it, of course. There is even every chance that he will fail, because he needs nothing less than the big Other. When the Eternal Father is no longer there to fulfill this role, there is no longer anyone. And if you address yourself to a woman, Wanda of course, there is no chance. She will understand nothing about it the poor thing. But even though the masochist fails he enjoys it all the same. So that he can say that he is the master of the real game. It is quite obvious that we do not dream for an instant of imputing such success to the psychoanalyst. That would be to trust him about the search for his enjoyment and we are far from according this to him. Besides it would be very inappropriate.

To put forward a formula that has its interest because I will have to take it up again and you must not be surprised, in connection with the obsessional, we will say that the psychoanalyst plays/makes the master

(*fait le maitre*) in the two senses of the word *faire*. Pay a little bit of attention for just five minutes more because it is very much of a short circuit and it is delicate. You sense well that the question about the psychoanalytic act, is, as I told you earlier, that of the decisive act that (289) from the psychoanalysand makes there arise, be inaugurated, be established the psychoanalyst. If, as I indicated to you earlier the psychoanalyst is confused with the production of the doing, of the work of the psychoanalysand, it is here that one can really say that the psychoanalysand makes (*fait*), in the strong sense of the term, the psychoanalyst. But one can also say that at the precise moment the aforesaid psychoanalyst emerges, if it is so hard to grasp what can push him into this, it is indeed because the act is reduced to playing, in the sense of a pretence, to playing the psychoanalyst, to playing the one that guarantees the *subject supposed to know*. And who, at the start of his career, has not confided to whoever wants to aid him in his first steps that he has precisely this feeling of pretending to be a psychoanalyst (*de faire le psychoanalyste*)? Why remove its value from this testimony?

But this is what allows, by taking up these two functions of the word *faire*, to say that it is quite true that in leading someone to the term of his psychoanalysis, to the term of this incurable truth, to the point of the one who knows that if there is indeed an act, there is no sexual relationship, is it not here, even if this does not happen too often, to ensure somewhere a true mastery? But on the other hand, contrary to the masochist, if the psychoanalyst for his part also can be said to have some relationship to the operation, it is certainly not because he is the master of it. But that all the same, he supports, he incarnates the trump card, in so far as he is the one who brings into play the whole weight of what is involved in the o-object.

What then, after having only pushed this discourse this far today, what about the point where this discourse itself can be situated, namely from where I state it? Is it from where the *subject supposed to know* keeps himself? Can I play the scholar in speaking about the psychoanalytic act? Certainly not. Nothing is closed off about what I am opening up as a question concerning what is involved in this act. That I am the logician of it, and in a way that is confirmed by the fact that this logic makes me odious to everyone, why not? This logic is articulated from the very co-ordinates of its practice and from the points where it takes its motivation. Knowledge in so far as it is produced by the truth - is this not what a certain version of the relationships between knowledge and enjoyment imagine?

For the neurotic, knowledge is the enjoyment of the *subject supposed to know*. This indeed is why the neurotic is incapable of sublimation. Sublimation for its part is the proper of what makes the circuit of what the *subject supposed to know* is reduced to. Every artistic creation is situated in this circumscribing of what remains irreducible in this knowledge *qua* distinguished from enjoyment. Something nevertheless comes to mark its enterprise, in so far as never in the subject does it designate what is its inaptitude for its full realisation.

Does not this imputation that the work of the exploited person is supposed in the enjoyment of the exploiter find something like its analogue at the entrance of knowledge? In the fact that the means that (290) it constitutes will make those that possess these means profit from those who win this knowledge by the sweat of their truth. No doubt the analogy would miss the point by operating in such distinct domains, if for some time, knowledge had not shown itself so

complicit with a certain mode of exploitation. Under the name of capitalist, as it happens, the excess of exploitation is something that is not liked. I am saying is not liked because there is nothing more to be said. The principle of revolutionary agitation is nothing other than that there is a point where things are not liked. Now, if you remember, did I not mark last year that the position of the analyst, if it ought to remain in conformity in all rigour to his act, was that, in the field of what he inaugurates with the help of this act as doing, there is no place for there to be something that he does not like, nor that he likes either. And that if he makes room for this, he leaves it.

But this is not to say for all that that he will not have his word to say about what can divert, limit those who, in a certain field which is the field of knowledge, have got to the point of rebelling about a certain going astray of knowledge, about the correct way, that favours knowledge emerging once again from a field where it exploits. It is on this last word that I am leaving you, promising you for the next time to enter into the detail of what is at stake concerning the respective positions of the hysteric and the obsessional with regard to the big Other.

Seminar 24: Wednesday 18 June 1969

(307) I would be in an even more excellent mood if I didn't feel like yawning as you have just seen me do, because of the fact that I had, I do not know why, by pure chance, a short night. My excellent mood is founded on these things that you have between two doors and that is called a hope. On this occasion, that it is possible, if things turn out in a certain way, that I may be liberated from this weekly sublimation that consists in my relations with you. "You do not see me from where I look at you", I stated in the course of one of these seminars of the previous years, to characterise what is involved in a type of o-object in so far as it is grounded in the look, that it is nothing other than the look. "You owe me nothing from where I devour you, *tu ne me dois rien d'ou je te devore*". Such is the message that I might well receive from you in the form that I defined in its inverted form in so far as it is itself mine. And I would no longer have to make the return journey here every week around an o-object which is properly what I am designating thus by a formula that as you sense – duty (*devoir*), devouring (*dévoration*) – is inscribed in what is properly called an oral drive. It would be better to refer it to what it is, the placentary thing onto which I stick myself as I am able. This great body that you constitute, to constitute from my substance something that might be for

you the object of a satisfaction. “Oh! My mother Intelligence” as someone or other has said.

Today then, I am only going to half keep my word about what I told you the last time. Because it is only in the form of a riddle that I am rapidly questioning you about what may take shape in your minds about something which explains why, from next year, I will no longer have at my disposition this place where you do me the honour of crowding in, because of what I produce here. I was made an assistant lecturer by a rather noble school, the one described as *Hautes Etudes*. I was offered shelter by this School in this School here, *Normale Supérieure*, a protected place, that is distinguished by all sorts of privileges within the university. It was an eminent philosopher, whom I am designating, I think, sufficiently in these terms – an eminent philosopher, there are not a lot of them – who teaches here, who became my intercessor with the administration here so that I could occupy this room. Is it this very occupation that serves as a reason for my no longer disposing of it? I do not think that I am occupying it at a time that anyone else might envy. Is it because my presence here (308) generates a sort of confusion in that my teaching is authorised by the *Ecole Normale Supérieure*, that I have just characterised here by the eminence it benefits from being in the university or more exactly excluded from it in a certain way. It should be remarked here that I have never authorised myself here by anything except the field whose structure I am trying to maintain in its authenticity. And that in truth I never authorised myself by anything else, and very especially not from the fact that these statements are produced in the *Ecole Normale*. Perhaps having me as a neighbour induced a certain movement in the *Ecole Normale*, a short, limited one moreover, that in no case seems to be able to be inscribed as a deficit. The *Cahiers pour l'analyse* that

have appeared, in a way induced by the field of my teaching, cannot be seen as a deficit, even if one can say that it was not at all by me that the work was done.

So then, many reasons here for there to be no urgency to distinguish me from the *Ecole Normale*. Certainly there was somewhere, in a single place, a confusion made in this respect. Namely, a person I told you about on 8th January last. In an article that I must say is rather comical, that appeared in a journal that protected him very well, the *Nouvelle Revue Française*, someone brought up something or other that was called an extract, indeed an exercise of my style. And in this connection I was qualified, entitled by what was called my quality of professor, that I certainly am not, and still less at the *Ecole Normale*.

If it is because of this confusion in an article that moreover was marked by many other confusions, I mean that articulated my teaching in function of something or other that made of it a commentary on de Saussure, which it never was. I took de Saussure as one takes an instrument, a system, to be used for quite different ends, those of the field that I designated earlier. In this connection something or other was stated which is supposed to be articulated from nothing other than from the fact that I am supposed to have read him, as they say, diagonally. This simply shows in the person who wrote this article a surprising ignorance of the uses that this word diagonal can have. Because it is quite clear that I did not read de Saussure diagonally in the sense that I read the articles in *Le Monde* diagonally. They are made for that, de Saussure's course is certainly not. On the other hand the method described as diagonal is well known for its fruitfulness in mathematics, namely, by revealing that from any series (*sériation*) that claims to be exhaustive one can, by the diagonal method, extract some

other entity that it does not include in its series. In this sense, I would be happy to accept that I made a diagonal use of de Saussure. But that from this, namely, from something that comes from an uncritical attitude that one might benevolently account for by an oversight that goes completely beyond this lack of criticism, to find in it material to (309) consider that some third person might see in it the justification for taking precautions, while it would simply be enough to point out that this oversight is nothing but that, and this on the part of someone who gave sufficient proofs of it in the rest of his text, there is obviously something or other rather curious. It suggests that when all is said and done the discussion about knowledge is excluded from the university. Because one can accept that someone who obviously is mistaken on one point may be able on another one to advance an incorrect qualification. This of itself justifies that it should be corrected by a measure other than pointing out to the person that there could be no confusion. This indeed is the conclusion that I am indicating now and that deserves to be drawn from it.

I will leave things there then, leaving you in suspense about whether any more can be said about it today. I am giving you explicitly a rendezvous then, the next time. This will be my next seminar when, accepting that it is in any case the last for this year, I believe I will be able in any case to promise you that I will distribute a certain number of little papers that I have in this briefcase, already prepared for you. In the case that this accent of finality is subsequently reinforced, this will mark at least something that will of course not be a diploma but a little sign that will remain to you of your presence here this year.

At this point, I am taking up again what I stated then the last time. Namely, what is pointed up by what I meant to articulate this year

about the terms *From an Other to the other*, to which I was able the last time to give a certain structural form. I recall in short that what is involved is the following. That anything that allows itself to be caught up in the function of the signifier can nevermore be 2 without there being hollowed out in the locus described as that of the Other this something to which I gave the last time the status of empty set. This to indicate the way in which, at the present point of logic, there can be written what, on this occasion and without excluding that this can be written differently, what, I say, changes the relief of the real.

I am writing again the 1, this circle that we first used to write the Other. And in this circle, taken here to function as a set, two members, the 1, and then something that, if it is still the Other, is to be taken here under the heading of set. A set in which for reasons linked to mathematical usage it would be wrong to put a zero to designate the empty set. It is therefore more correct to represent it according to the classical style of set theory as follows, namely, to mark it with this oblique bar that you know moreover I make use of. Anything that allows itself to be taken up into the function of the signifier can no longer be 2 without there being hollowed out, and in a way that organises the field of this dual relation, in such a way that nothing can (316) any longer happen in it without being obliged to turn around this thing here at the extreme right that I called an empty set. That is properly – this for those that have put in the time to understand it – what, in my *Ecrits* as well as in my propositions, I always designated as the *additional one (un-en-plus)*. This then means, indicates, that in the measure that my discourse, as I might say, advanced, if I had to introduce into the function and into the field of speech and language what was involved in the function of the unconscious by having recourse to this fragile and oh so problematic term of intersubjectivity,

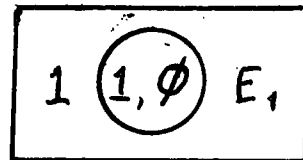

to put the accent more and more on what, of course, is required by Freud's second topography, namely, that nothing functions or is regulated there except intra-subjective correlates. Here comes the decisive accent put on this function of the *additional one* as exterior to the subjective.

Let us consider the drawing in which already the last time I made operate what I wanted to articulate for you about these remarks that I am taking up again today. Who does not see, I said, how by implicating a subject in the formula that a signifier represents it for another signifier, *from an Other* is already inscribed in this formula. This signifier for which the subject is represented is properly this *an Other* that is at stake in my title. This *an Other* that here you see inscribed because it is the resource for which what has to function as a subject is represented, in this field of the Other. This *one in the Other* as such cannot work without involving the *additional one*. That is why it is only at the moment that these three basic signifiers are inscribed, in so far as of themselves they already carry an effect of signifier and that it is sufficient to have to be inscribed in this way, as you see in a way that is not self-evident, that demanded months and years of explanation for those very people whose practice could not be sustained for a moment without being referred to this structure, I mean psychoanalysts. Just by themselves, these three terms inscribed under this mode of inscription, these three terms indeed constitute, in terms of what they already imply, before there is a question of making the apparition of the subject arise from it, a structure. Already, by their articulation, they constitute a knowledge.

This *an Other* here inscribed by 1 on the left of the circle, shows itself for what it is, namely, one in the Other, the one for whom the subject is

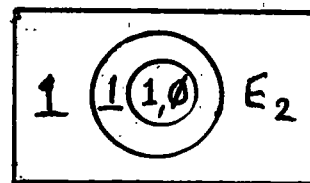

found to represent itself from the One. What does that mean? Where does this 1 come from, this 1 for whom the subject is going to be represented by the 1? It is clear that it comes from the same place as this 1 that represents, that this is the first phase from which the Other is constituted. And if the last time I compared this locus of the Other to a Trojan Horse that functions in the opposite sense, namely, that each (311) time swallows a new unit into its belly instead of allowing them to be disgorged into the nocturnal city, it is because in effect this entry of the first 1 is foundational. Foundational in something that is very simple, namely, that it is the minimum necessary for this to be. The Other cannot in any way contain itself except in the state of subset.

Let us clearly understand one another. Can one say that here this Other contains itself, if I furnish this empty set with something that repeats these members, first a 1, and the empty set? It is not true that one can say that this means it contains itself. Because this set transformed in this way, is inscribed from members that we have just mentioned. And the totality of these members is not what is reproduced here from the couple first inscribed as that of the first set E_1 , namely, the member 1, then the empty set, the empty set where now there is reproduced the member 1, the empty set. There is therefore no question of the set of all the sets that might not contain themselves, for the simple reason that at the level of the set, there are never sets that contain themselves. To talk about the set of all the sets that do not contain themselves does not constitute a set. But it is clear that the question of whether the set can, yes or no, contain itself is only posed, can only be posed by having absorbed this *an Other*, so that by its inclusion there appears as the *additional one* the empty set, for the reason that grounds the empty set as not being able to be in any case 2. There is no empty set that contains an empty set. There are not two empty sets.

The inclusion then of the first 1 is what makes it necessary that in the field of the Other, the most simple formula for 2 to be inscribed is the 1, member, and the empty set, inasmuch as it is nothing else but what is produced in a set with one member, by distinguishing the subsets from it. The 1 just by itself sufficed for a long time. This allowed it to be said that the Other, was the 1, a confusion in that the structure of the set was not recognised. Even in the set with one member posited as such, there emerges as a subset this *additional one* that the empty set is. In other words the Other needs an other to become *additional one*, namely, what it is itself. What is produced then from the one to the other, in so far as it is a second, is another signifier, And in the Other, it is properly this that ensures that it is only at the level of the second 1, of S_2 if you want to write it in this way, that the subject comes to be represented. The intervention of the first 1, of S_1 as representation of the subject only implies the apparition of the subject as such at the level of S_2 , of the second 1. And from then on, as I pointed out the other day, namely, that the *additional one*, the empty set, is $S(O)$ namely the signifier of the Other, the inaugural O.

What this shows us, is that there is going, in the structure thus defined, that the relationship of the 1 inscribed in the first circle of the Other, to this second circle of the *additional one*, which can itself contain the 1 + the *additional one* which is distinguished from this relationship to this 1, and only by this not being the same empty set, but can repeat the same structure indefinitely. This same indefinitely repeated structure of the 1, circle 1, circle 1 and so on, this is what defines the Other. Namely, this is the very thing that constitutes the agency of the o-object as such. It is indispensable that there is at least one member reduced to the member 1 in the Other. This is what made the Other be

taken for 1 for a long time. As I told you, there is a psychical structure that restores, as I might say, the apparent integrity of O, that grounds in an effective relation the S(O) as not marked by what the bar on the top left of our graph designates, S(\emptyset). This is nothing other than the identification of this indefinitely repeated structure that the o-object designates. In truth, I would employ the following metaphor to designate as a perverse structure the apparent restoration of the integrity of the Other in so far as it is the o-object, that is in a way the imaginary moulding of the signifying structure.

We are going to see later in effect what fills the place of this O, in the operation of psychic identification. In a word, let us see it right away. Let us spell out the texts, taking the first case to be presented under the figure of the hysteric, to Freud. We are going to see how he, who gives to this economy its first explanation, goes along with her. How in connection with Anna O, he does not question himself about what is involved in the relationship between these narratives, this *talking cure*, as she herself puts it, inventing the term, and this symptom that is particularly clearly designated in the case of the hysteric. Something at the level of the body that is emptied out, a field where sensitivity disappears. *An other* connected or not whose motor activity becomes absent without anything other than a signifying unit being able to account for it. The anti-anatomical nature of the hysterical symptom was sufficiently highlighted by Freud himself. Namely, if a hysterical arm is paralysed, it is because it is called arm (*bras*) and nothing else. Because nothing in any real distribution of impulses whatsoever accounts for the limit that designates its field. It is indeed the body here that comes to serve as a support in an original symptom, the most typical in that, because it is at the origin of analytic experience itself, we question it.

Where then is, with respect to the progress operated by the talking cure, *la cure parlante*, how not remain as close as possible to the text. And even without knowing any more about it – which is not the case because we know a lot more, I mean that it is necessary to organise this structure differently – how can we not see that Freud here is at the place of the 1, here placed as inside. It is in Freud that there is established a certain subject. Without the listener, Freud, the question (313) is to know how he could subject himself to this function for one year, two years, to listen every evening, at the moment that a dissociated state marked the cutting, the cut by which Dora, by which a symptomatic Anna was separated from her own subject. How can we not question ourselves about the hidden relationship that ensured that simply by taking things as they were presented, that it is from the fact that a subject comes to know something that is a feature (*trait*), if you remember this observation, a feature moreover followed like a historical reprise, not lost in the darkness of some forgetting or other, simply cut off just the previous year. And that, in the measure that with this delay which just by itself ought to have a sense for us, means that when Freud was informed about it, the symptom whose relationship is only a distant one, is only forced with respect to what is articulated in it, the symptom is removed.

This foundation of a subject creates knowledge in a field which is that of the Other, and its relationship with this something creates a hollow at the level of the body. Such is the first outline that when we have elaborated it sufficiently after decades in order to be able from this structure in its unicity to make the collection, under the heading of what functions as the object described as *o*, which is this structure itself, we might say that with regard to this body emptied in order to

function as a signifier, there is something that can be moulded there and this metaphor will help us to conceive as a statue properly speaking what, at the level of the pervert, comes to function as that which restores as plenitude, as O without a bar, this O. To appreciate the imaginary relation of what is involved in perversion, it is enough to grasp the statue of which I speak at the level of a baroque contortion whose representation of an incitement to voyeurism is only tangible in so far that it represents a phallic exhibition. How can we not see that used by a religion concerned with re-establishing its empire over souls at the moment that it is contested, the baroque statue, whatever it may be, whatever male or female saint it represents, indeed the Virgin Mary, is properly this look that is designed so that the soul may open up before it. If the rapprochement I made between a single feature of the perverse structure and some capture or other of the faith that must indeed be called idolatrous, puts us at the heart of what is presentified in our West by a quarrel over images, it is something exemplary that we have to draw profit from.

I said that I would tackle today what is involved in neurosis. And, as you heard, I began at the level of the obsessional, by articulating that nothing of the obsessional can be conceived of except by referring to a structure in which, for the master, in so far as he functions as 1, a signifier that only subsists by being represented for a second 1 that is in the Other, in so far as this represents the slave in whom alone resides the subjective function of the master. Between one and the other there is nothing in common except what I said had first been (314) articulated by Hegel as the bringing into play at the level of the master, of his own life. The act of mastery consists in this, the risk of life. Somewhere in this little book that has come out under the heading of the first number of *Scilicet*, I highlighted in the miraculous remarks

of a child, what I gathered from the mouth of his father, because he had told him that he was "a trickster of life, *tricheur de vie*". An extraordinary formula, like those that undoubtedly one can only see flowering in the mouths of those for whom no one has yet confused matters. The risk of life, this is the essential of what one can call the act of mastery. And its guarantor is none other than what is, in the Other, the slave as signifier by whom alone the master is supported as subject. His support being nothing other than the body of the slave in so far as it is, to use a formula that had good reason to come into the forefront of spiritual life, *perinde ac cadaver*. But it is such only in the field by which the master is supported as subject. Something remains outside the limits of this whole apparatus, which is precisely what Hegel wrongly brought into it, death. Death, as has been sufficiently noted, is only profiled here in that it does not contest the whole of the structure except at the level of the slave. In the whole of the phenomenology of the master and the slave, only the slave is real. And this indeed is what Hegel glimpsed and it would be enough to ensure that nothing goes any further in this dialectic. This situation is perfectly stable. If the slave dies there is no longer anything. If the master dies everyone knows that the slave is still a slave. As long as we have known about slaves, the death of the master never freed anyone from slavery.

Such is, I would ask you to note, the situation when it is the neurotic that introduces the dialectic. Because it is only from the moment that we presuppose somewhere the *subject supposed to know* that in effect, with this horizon and with good reason, just like the rabbit in the hat, it is put in at the start, we can see there progressing then in a dialectic what is stated about the relationships of the master and the slave. And where? At the level of the slave himself towards an absolute

knowledge. The subject, it is in so far as the master is represented at the level of the slave that the whole dialectic is pursued and culminates at this end which is nothing other than what is already put there under the function of knowledge. This function precisely in so far as it is not criticised, that nowhere is there questioned the order of underpinning of the subject in knowledge. This thing which nevertheless leaps to the eye, which is that the master himself knows nothing. Everyone knows that the master is a fool (*un con*). He would never have entered into this whole adventure, with what the future designates for him as a resolution of his function, if for an instant there existed the subject that, in his facile way of talking, Hegel imputes to him. As if this function of the fight to the death, of the fight for pure prestige, could be set up, in so far as it also makes him substantially depend on his partner, if the (315) master were not something other than what we properly call the unconscious, namely, unknown to the subject as such. I mean this unknown from which the subject is absent, the subject of which is only represented elsewhere.

All of this is only done to introduce the next step of what I have to articulate today. Previously, I spoke in connection with the hysteric about the analogue she took on from her reference to the woman. Just as I said that nothing that is articulated about the obsessional constitutes him except to introduce into the dialectic of the subject-master, what necessitates something that calls him, namely, the truth of this process. And, on the path of this truth, the taking up, the bringing into play of the *subject supposed to know*.

I am taking this up at the level of the other neurosis, of the hysteric. And to put at the heart of it the analogous apparatus, the model that is at stake, to which the obsessional refers himself, I already said, the

hysteric, just as one can say that the obsessional does not take himself to be the master but supposes that the master knows what he wants, in the same way, the hysteric for the woman – not that the hysteric is for all that obligatorily a woman any more than the obsessional is obligatorily a man, it is a matter of the reference to the model of the master – in the same way, the hysteric, her model, is what I am now going to state in that what is involved in the model in which the woman establishes this thing that is much more central, as you are going to see, in our analytic experience.

When I put it forward, sometime around the 21st May, someone here posed me the question: but do we know what the woman is? Naturally, no more than we know what the master is. But what one can outline, is the articulation in the field of the Other of what is involved in the woman. It is just as stupid as the master, make no mistake. I am not for the moment talking about women, I am speaking about the subject “the woman”. Do we not see what is involved in these two 1’s when we are dealing with the woman? The inner 1, S₂, make no mistake, what it is a matter of seeing being erected does not appear doubtful to me and it then becomes very clear. It is to know why the 1 by which the woman subject is supported is so ordinarily the Phallus with a capital P. It is at the level of the 1 that it is a matter of bringing up that the identification of the woman in the dual mirage in so far as this Other is at its horizon, the empty set, namely a body, a body here emptied of what? Of enjoyment. Where the master-subject takes on the risk of life, in the inaugural wager of this dialectic, the woman – I did not say the hysteric, I said the woman because the hysteric, as the obsessional earlier does, is only explained by reason of these references – risks, wagers this enjoyment which everyone knows is for the woman inaugural and existing, and is such that without any of

these efforts, of these detours that characterise autoerotism in the man, not only does she obtain but she always subsists distinct from and parallel to the one that she takes from being the wife of a man, the one (316) who is satisfied by the enjoyment of the man.

This enjoyment of the man that the woman takes, captures for herself as the master does to the slave, this is the stake of the game and gives its radical origin to what is involved in what here plays the same role as death for the obsessional and is just as inaccessible. Namely, that to say the woman identifies to it – I said the woman – is just as false, is just as vain as to say that the master identifies to death. On the contrary, just as the slave is bound and in the same way, I mean only subsists through the relation to death and with this relation makes the whole system subsist, the relationship of man to castration is also what here makes the whole system hold together. And moreover, if I earlier spoke of *perinde ac cadaver*, I would evoke here something rather remarkable that for the being caught up in the field of the signifier, the dimension called necrophilia exists, in other words erotism and very properly applied to a dead body. Do I need to evoke here on the horizon the figure Jeanne la Folle and her trailing about for a fortnight the body of Philippe le Beau?

It is only with respect to these structures, to these inaugurating functions in so far as they alone correspond to the introduction of what is properly the dependency on the signifier as analytic experience allows us to articulate it, that we can here see, just as for the obsessional, the hysteric is introduced as not taking herself for a woman. How does she not take herself for a woman? Precisely in the fact that she supposes that, in this structure, that I have just articulated as being that of the woman subject, this subject, at the level of the

starting S_1 , she makes into something supposed to know. In other words she is captivated, interested – remember Dora – by the woman in so far as she believes that the woman is the one that knows what is necessary for man's enjoyment. Now, what results from this something that is absent in the model, the function of the woman-subject, God be praised, make no mistake, does not know that what she is sustaining culminates in the castration of the man.

But, on the contrary, the hysteric is not unaware of anything about it and that is why she questions herself beyond what I already articulated about Dora, centred on a first approach that I made to transference. Beyond. Re-read the observation, and moreover do not omit everything that in the prior observations, those of *Studies in hysteria*, allows simply the following to be seen. The correlation between the fact that, for the hysteric, the woman supposes her knowledge of what is in the model, she does it unconsciously. That is why the two models not being able to be distinguished by this factor that is introduced that reunites under the heading of neurosis one type just as much as the other, you can note that the correlate of death is at stake in what the hysteric tackles about what is involved in being a woman.

The hysteric plays the man (*fait l'homme*) who supposes that the (317) woman knows. That indeed is why she is introduced into this game from some angle where the death of the man is always involved. Is there any need to say that the whole introduction of Anna O to the field of her hysteria does nothing other than turn around the death of her father? Is it necessary to recall the correlate, in the two dreams of Dora, of death in so far as it is implicated by the mother's jewel box. "I do not want, says the father, my children and me to perish in flames

because of this box” and in the second dream that it is a matter of the burial of the father. Hidden truths, neuroses suppose them known. They must be disentangled from this supposition so that they, the neurotics, stop representing this truth in the flesh.

It is in as far as the hysteric, as one might say, is already a psychoanalysand, namely, already on the path of a solution, of a solution she seeks starting from the fact that in what she refers herself to she implies the *subject supposed to know*, and that is why she encounters contradiction. The fact is, as long as the analyst does not practice the cut between the unconscious structure, namely, the models that I properly articulated here of the 1, 1, the empty set, as much at the level of the master as at the level of the woman, namely, from what has made the neurotic naturally a psychoanalysand because here and now constituting in herself, and before any analysis, the transference. The coalescence of the structure with the *subject supposed to know*, this is what is testified in the neurotic by the fact that she questions the truth of these structures and becomes herself in the flesh this questioning. And that if something can make drop the fact that she is herself symptom, namely, precisely by this operation of the analyst practicing the cut thanks to which this supposition of the *subject supposed to know* is detached, is separated from what is at stake. Namely, the structure that she correctly locates, except for the fact that neither the master, nor the woman can be supposed to know what they are doing.

The operation of analytic treatment turns around this cut which is a subjective cut, because undoubtedly everything that we say about an unconscious desire, always, of course, supposes that a subject ends up

by knowing what he wants. And what does that mean? Do we not here again still preserve, in stating such formulae, this something that means that there is knowledge and what one wants. Assuredly there is a locus where the two terms are distinguished. It is when it is a matter of saying yes or of saying no to what I called, what one wants. This is what is called the will. But to know what he wants, is for the master, as for the woman, desire itself, just as earlier I unified the three words of *an additional one (un-en-plus)*, the knowing-what-he-wants that I mean here, is desire itself. What the hysteric supposes, is that the woman knows what she wants, in the sense that she is supposed to desire it, and this indeed is why the hysteric does not manage to (318) identify herself to the woman except at the price of an unsatisfied desire. In the same way, with respect to the master, whom he makes use of in the game of hide and seek to claim that death can only touch the slave, the obsessional is the one who, from the master, only identifies this thing which is the real, that his desire is impossible.

Seminar 25: Wednesday 25 June 1969

(319) Try not to lose the thread about what you are as effect of knowledge. You are split apart in the phantasy ($\$ \diamond o$). You are, however strange this may appear, the cause of yourself. Only there is no self. Rather there is a divided self. Entering onto this path is where the only true political revolution may flow from. Knowledge serves the master. I am coming back today to underline that knowledge is born from the slave. If you remember the formulae that I aligned the last time, you will understand that, in parallel, I state: knowledge serves the woman, because it makes her the cause of desire. Here is what I indicated to you the last time, in a commentary on the schema that I am writing out again. I think I should take it up again, even for those who may be occupied elsewhere by concerns that appear more important to them.

Here is this schema. This schema emerges from the logical definition that I gave at our second last meeting of the Other as empty set and of its indispensable absorption of a unary trait, the one on the right, in order that the subject may be able to be represented there for this unary trait, under the species of a signifier. Where does this signifier that represents the subject for another signifier come from? From nowhere,

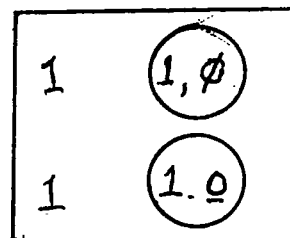

because it only appears at that this place in virtue of the retro-efficacy of repetition. It is because the unary trait aims at the repetition of an enjoyment that another unary trait arises subsequently, *nachträglich* as Freud puts it. This term I was the first to extract from his text and to highlight as such. Whoever amuses himself in translating a certain "*Vocabulaire*", will be able to see that at this rubric of *après-coup*, which would not even exist without my discourse, I am not even mentioned. The unary trait arises in a deferred way, in the place therefore of S_1 , of the signifier, in so far as it represents a subject for another signifier. On this I say: everything that is going to arise from this repetition that is repeated by the introduction of the in-form of o , here the sign of the empty set, is first of all this in-form itself, and this is the o -object.

At this people get alarmed: I am told: "So then, you are giving a purely formal definition of the o -object." No, because all of this is only produced from the fact that at the place of the 1 on the left, of S_1 , there is what there is, namely, this enigmatic enjoyment attested to by the fact that we know nothing about it except the following, that I am going to reproduce at every stage where it is distinguished, nothing is (320) known about it except the fact that it wants another enjoyment. This is true everywhere. 4, 2, 3, the little fable to which is given the ridiculous answer that you know; at the answer, to have another one. In this Oedipus, the hysteric who has answered, answered in so far as the truth about the woman must indeed have been said for the Sphinx to have disappeared because of it. That is why, in conformity with the destiny of the hysteric, he subsequently played the man.

The hysteric, I will tell you...because there is going to be some little time before we meet again, the hysteric fills me with joy. She

reassures me more than she did Freud, who was not able to understand that the enjoyment of the woman was perfectly sufficient in itself. She erects this mythical woman called the Sphinx. She articulates that the original game is that she must have something else, namely, enjoy the man, who for her is only the erect penis by means of which she knows herself as other, namely as phallus, of which she is deprived, in other words as castrated. Here is the truth that allows some lures to be dissipated and remind you that this is the year that I posited the *o* as *surplus enjoying*, in other words the stake that constitutes the wager in order to gain the other enjoyment.

That is why the last time I wrote the dialectic of the master and the slave differently by clearly marking that the slave is the ideal of the master. That he is also the signifier to whom the master-subject is represented by another signifier since what is at stake is the third term of data representations other than formal. Here it is in the form of the stake which here is *o*. In this dialectic, as a philosopher named Hegel glimpsed, the stake is indeed what can hold up in a signifying in-form as 1, a life. It is true that you only have one. Equally, it is an idiotic formulation because you cannot formulate that you only have one on the principle that you might have others, which is manifestly outside the game. A life, this indeed is what Hegel said, but he was wrong about which one. The stake is not the life of the master, it is that of the slave. His other enjoyment is that of the life of the slave. Here is what this formula of the fight to death envelopes, so completely closed, what one finds in the box. The fight to the death is a signifier, that is what it is.

It is all the surer in that it is very probably nothing other than the signifier itself. Everyone knows that death is outside the game. We do

not know what it is, but the verdict of death, is the master as subject, a signifying verdict; perhaps the only true one. What he lives from, is a life, but not his own, the life of the slave. That is why any time the wager on life is at stake, it is the master who speaks. Pascal is a master and, as everyone knows, a pioneer of capitalism. For reference: the calculating machine, and then the bus. You have heard tell of that in some corner or other, I am not going to give you a bibliography.

This has a dramatic air; up to a certain point it has become such. At (321) the beginning it was not so, for the reason that the first master knows nothing about what is doing. And the master-subject is the unconscious. In ancient comedy, whose value as an indicator could not be exaggerated for us, it is the slave that brings to the master or to the son of the master – it is better again than the Son of Man, that imbecile – who brings him news of what is being said in the town, for example, from which he has come post-haste. He also tells him what to say, the passwords. The slave of antiquity, read Plautus better again than Terence, is a jurist, he is also a PR man. The slave was not a latecomer in antiquity. Do I need to pinpoint in passing two or three little notes that will perhaps be heard by an ear or two here, namely, that of course there are masters who have tried out knowledge, but after all why should the whole knowledge of Plato not be an unconscious philosophy? It is perhaps for that reason that it is of such profit to us. With Aristotle we pass onto a different plane. He serves a master, Alexander, who for his part undoubtedly absolutely did not know what he was doing. All the same he did it very well. Since Aristotle was at his service, he produced after all the best natural history there has ever been, and he began logic, which must mean something.

Along what path then did the master come to know what he was doing? In accordance with the schema that I gave you earlier, along the hysterical path, by making of the slave the damned of the earth. He worked hard. He substituted for the slave surplus value, which was not something easy to find, but which is the awakening of the master to his own essence. Naturally, the master-subject could only articulate himself at the level of the signifier slave. Only this elevation of the master to knowledge permitted the realisation of more and more absolute masters than have ever been known from the beginnings of history.

To the slave, there remains class-consciousness. This means that he can just shut up. Everyone knows that I am telling the truth and that the problem of the relationships of class-consciousness to the Party are the relationships of the one to be educated to the educator. If something gives a sense to what is called Maoism, it is a taking up of these relationships between the slave and knowledge. But let us wait to see things more clearly. Up to now, the proletariat, like this philosophy of the master, the first one, had the gall to call it, had the right as you know, to abstention. You see that if people dare to say in these places of misinformation quite explicitly forged for this goal, that psychoanalysis only ignores class struggle it is not perhaps altogether certain, and it can perhaps restore its true sense to it.

You must not imagine that speaking out, as it is put, frees you in any way whatsoever, just because the master, for his part, speaks out and even a lot. But it is enough to take this phantasy at its place for the affair to be resolved; it is puerile. Do I need to say that this year I began my discourse on psychoanalysis by saying that psychoanalysis, (322) is a wordless discourse. Knowledge displaces things, not

necessarily to the profit of the one for whom it claims to work. It claims moreover for, as I told you, knowledge is nothing like work. The only solution is to enter the defiles without losing the thread, it is to work at being the truth of knowledge.

If then, to take up at the two levels of the master and the slave what is involved in these three terms, I rewrite here S_1 , S_2 , o , sufficiently commented on I think, and I remind you, at the same time as I am completing it, of what I wrote the last time under another form, what concerns this relationship of the woman to her Other enjoyment, as I articulated it earlier. The woman who becomes cause of desire is the subject of whom it must be said – re-read the Bible a little bit – who would ever say (.....?.....) about this story if he had not first been offered the apple, namely, the o -object. That is why, the signifier at the end, this Φ , the sign of what is assuredly lacking to the woman in the affair, and that is why he must furnish it.

It is amusing that after 70 years of psychoanalysis nothing yet has been formulated about what a man is. I am speaking about *vir*, the masculine sex. What is at stake here is not the human or other nonsense about anti-humanism and all this structuralist disorder, it is a matter of what a man is. He is active, Freud tells us. In effect, there is good reason for it. He even has to make an effort not to disappear into the hole. Anyway, thanks to analysis, he now knows that he is castrated; anyway he knows it at the end, that he always was so. Now he can learn it, a modification introduced by knowledge.

As you have seen, here there is something funny, it is this kind of non-adjustment; things have been detached from the 2, we have jumped from S_1 to o .

S ₁	S ₂	o
S ₂	o	S ₁
o	S ₁	2

Why would this not be done 1 by 1, that first of all there would have been this S₂, o, then S₁. We ought to be able to find our bearings in what that means. I am going to say the word to you right away, especially since you should be prepared. Earlier, I showed you a passage from the master to the schoolmaster, then the S₂, wherever it is, is the mapping out of knowledge. So then it is perhaps this that is at stake in the middle line. The hysteric marks what has remained at the S₂ on top, in the first line. But in any case where the S₂ is in its place, namely knowledge, at a master's place, look, you should recognise the place of stating.

I spoke to you about the *hommelle*. Does not all of this converge towards her, the *hommelle*, the one who is at once the master and knowledge? She speaks, she utters. If you wanted to have an image of (323) her, you should go and see something, but go in at the right time, as I did. It is a detestable film called *If*, my word, God knows why. It is the English university displayed in its most seductive forms, the ones that conform to everything that, in effect, psychoanalysis was able to articulate about what is involved in a society of men, a society in the earlier sense, a society of homosexuals. There, as you will see, the *hommelle* is the rector's wife, she is a ravishing, really exemplary disgrace. But the lucky find, is the moment – I should say that it is the only stroke of genius that the author of this film had – of making her walk all alone and naked, and God knows if there are not some, among the pans of knowledge, in the kitchen, altogether sure that she is of

being queen in her own house. While the whole little homosexual *bordel* is in the yard marching preparing for some military occasion. So then you are beginning perhaps to see what I mean. The *hommelle*, the *alma mater*, the university in other words, the place where because of having practised a certain number of intrigues around knowledge gives you a stable institution, under the crook of a spouse. There you have the true figure of the University. So then we could perhaps identify rather easily what represents the σ here, the pupils, the little dears taken in charge, themselves the creation of the desires of their parents. So this is what they are asked to bring into play, the way in which they have escaped from the desires of their parents. And the bet is this S_1 that ought to be identified to this something that is happening round about called the student insurrection. It seems that it is very important for them to agree to enter into this game, by the way in which they argue about the subject of what is sold at the end, namely, a parchment, let us say, that may perhaps have some relationship with this S_1 . If you do not play the game, you will have no diploma this year. There you have, my God, a little system that permits in any case an approximation of the sense of these things where people no longer find their bearings, concerning what is now happening in certain places. I am not claiming to contribute any historical key. What I am stating, is the following. It is that to refuse to, only makes sense if the question is centred around the relationships that are precisely those around to which psychoanalysis takes the question, namely, what is called the relationship of knowledge and the subject.

What are the subjecting or subjection effects of knowledge? Student have no vocation for revolution. You can believe it from someone who having entered for historical reasons into the field of the University, very precisely because with psychoanalysts there was no way of

getting them to know anything whatsoever. So then a little hope that through the effect of reflection, the field of the University would make them reason differently. In short, a resonating drum for the drummer when he does not resonate himself, make no mistake. So then students, you understand, I have seen some throughout the years; to be a student is quite normally a servile position. And then you cannot (324) imagine that because you have spoken out in some little corner, the affair is settled. Students, in a word, continue to believe the professors about what should be thought in such and such a case about what they say. There is no doubt for students, there is an established opinion that in one or other case this is not worth much. But it is still the professor, namely, one expects from him all the same what is at the level of S_1 , which is going to make of you a master on paper, a paper tiger! I have seen students who have come to me saying: "You know, So-and- So, it's scandalous, his book is copied from your seminar". That's students for you. Me, I am going to tell you, I did not even open this book, because I knew in advance that there was nothing in it but that! They came to tell me, me. But to write it, is a different affair. And that is because they were students.

Good, what in the world could have happened so that all of a sudden there was this movement of insurrection. What does a revolt mean, Sire? In order for this to become a revolution, what would be necessary? It would be necessary for the question to be attacked not at the level of tickling some professors but at the level of the relationships of the student as subject to knowledge. It is because psychoanalysis says, this point connected for a long time, every knowledge implies a subject, as a result of which there quite gently slides in as well substance, well then no, it cannot work like that. Even the *upokeimenon* can be disconnected from knowledge. A knowledge that

the subject is unaware of, this is not a concept, as I had the sadness to read in a review of what, in a certain place, where psychoanalysis is put to the test. Naturally it is not for nothing. Psychoanalysis in such conditions would be better off not being charming and not to say that in short there is only a single Freudian concept, and to call it the unconscious, not even what I have just said, a knowledge the subject is unaware of. It is not a concept, at either of the two levels. It is a paradigm. It is starting from there that the concepts that, thank God, exist to mark out the Freudian field, and Freud produced others that, acceptable or not, are concepts, starting from this first phase of the experience, of this example which was the unconscious he discovered. The neurotic, is $s(O)$. This means that he teaches us that the subject is always another, but that in addition, this other is not the right one. He is not the right one to know what is in question, of what causes him, the subject. So then people try as best they can to reunify this \emptyset in the measure of what is involved in every significant statement, namely, to rewrite it $s(O)$, which is on the left and on the lower line of my graph. It should be stated, in other words, where one knows what one is saying. It is there that psychoanalysis stops, while what should be done, is to reconnect what is on the top left, the S, signifier of \emptyset .

(325) It is the same thing for the pervert who, for his part, is precisely the intact signifier of O, as I told you, and people try to reduce him to the s of the same O. Always the same thing, so that that means something. There you are. Do you believe that I am going to continue for long like that, huh? And under the pretext that today is my last class, to continue to tell you things so that at the end you will applaud, for once, because you know that after that, watch out, huh, I am off!

The discourse that I am speaking about has no need for these sort of glorious endings. It is not a classical *oratio*. And in effect, a discourse that is like a classical oration is not liked. A gentleman, who is here the administrative director of this establishment that is privileged with respect to the university, it seems that because of this the aforesaid establishment should have some control over what happens within it. It seems that there is no question of it, since it appears that in law, after having welcomed me at the request of one of the agencies of the school, like that, in a hospitable way, he has the right to tell me, that's it! I for my part agree, I completely agree. Because first of all it is true I am only here out of hospitality, and what is more, he has very good reasons that I have known about for a long time. It is that my teaching appears to him to be exactly what it is, namely anti-university in the sense that I have just defined it. He nevertheless took a very long time to say it to me. He only told me quite recently, on the occasion of a final little telephone call that I thought I should make to him, because there had been, I think, a type of misunderstanding that I absolutely wanted to dissipate before saying to him: "Of course, there is no question that...." etc. It is very curious that at that point he let it drop, in other words he told me that that was why. "Your teaching, he told me, your teaching is very with it (*dans le vent*)". You see that, the wind.... I would have believed that I was going against the wind here, but no matter!

Good, so then that he is within his rights, I have absolutely no reason to doubt, as regards myself. As regards you, it may be something else. But that is up to you. That for six years a certain number who have had the habit of coming precisely here are being evacuated, you see that does not count! This is even very explicitly what is at stake. In this respect, you understand I have some apologies to make to you, not

because you are being evacuated, I have nothing to do with it; I could have warned you earlier. I have a little note here that I received, intentionally, since the 19th of March. The 19th of March. It is very funny, because on the 19th of March, I did not give a seminar. I tried by every means since, because I could not be bothered. And then, as you will understand, I am not moved by the fact of speaking before you for the last time, because every time I come here, as I told you, I tell myself that perhaps finally it is going to be the last time.

So then one day when I was questioning myself, when I was (326) questioning you about this flood of people that you make up, I cannot even say that it was when I was going home, the following morning I received this little note that I am going to read to you. I did not tell you about it because I said to myself, if by chance that disturbed them, what complications there would be! For my part you understand I was once in a similar state for two years. There were people who spent their time trying to liquidate me; I allowed them to continue their little work so that my seminar should continue, I mean that I should be heard at the level where I had certain things to say. It is the same thing this year, as a result of which then I received this on the 20th of March, and it is dated the 18th of March. So then there is no relationship. I even kept the envelope. I had torn it up at first, I picked it up, and it is indeed stamped 18th. As you see, trust reigns!

Dr Lacan, 5, rue de Lille – as some of you know – Paris (7e).

“Doctor,

“At the request of the 6th section of the Ecole Pratique des Hautes Etudes, the Ecole Normale has put at your disposal a room to give a course for more than five years.

“The reorganisation of studies at the Ecole, which is a consequence of the general reform of the Universities... (laughter)....and of the recent law on the orientation of third level studies, as well as the development of teaching in several disciplines, is going to make it impossible for us to lend you the salle Dussane or any other room in the Ecole...(laughter)...for your course.

“I am giving you enough notice...(that’s true!) ...so that you can envisage from now the transfer of your course to another establishment at the re-opening of the next academic year 1969-70”.

Me, I really like that! I really like it; all of this is correct historically, it is quite true. It was in effect here at the request of the 6th section of the *Ecole Pratique des Hautes Etudes*, like that, following a transmission of personal debt that there was.....anyway there was an eminent man called Lucien Fèbvre who had, one could not say the unfortunate idea, he is not to blame for it, of dying before giving me what he had promised me, namely a place in this Ecole. Others had availed of this personal debt. The university is very feudal. That is the way it happens in..... One is indeed, as you know in the university, something like that, a liegeman. The liegeman, the *l’hommelle*, all of that holds together!

So then it is under this title, it is at the request, as they say, that I was there. Good. So then I am delighted that it should be highlighted here. I am not against, you understand, the reform (*laughter*) being the reason that is put forward. You understand, I am not a complete baby, I know well that at half past twelve on Wednesday, who wants the *salle Dussane*? Some trouble was taken to make the acoustics in this (327) room work. By the way, there are people here, I am going to

tell you all the same what you came to hear, I found that it was worth the trouble to make a number of photocopies that I hope is sufficient for my listeners today. The people to whom I gave these documents are going to distribute them to you; I would ask you to take only one each. What is more, this will be something or other. It is the S_1 you understand. You will all be bound together by something, you will know that you were here on the 25th of June 1969. And that there is even a chance that the fact that you were here on that day bears witness to the fact that you were here for the whole year. It is a diploma!

(Applause)

You never know, that may help us to find one another because who knows, if I disappear into the wilds and one day I come back, it will be a sign of recognition, a symbol! *(Laughter)* I may very well say one day that any person can enter a particular room for a confidential paper on the subject of the function of psychoanalysis in the political register, because you cannot imagine the degree to which we are questioning ourselves about this! It is true that fundamentally there is here a veritable question about which one day, who knows, the psychoanalyst, even the University, may have some advantage in getting some idea of! I would be rather inclined to say that if ever I was the one who was asked to put forward something about it, I would give you a rendezvous in this room *(laughter)*, so that you would have a final class for this year, the one that you are not getting, in short, because I stopped earlier. I stopped in order not to give a final class. This does not amuse me. So then you have this little object in hand. There are 300 all the same, 300 evacuees!

Since that is how we are now, after all I must leave you to leave you a little time among yourselves; it would not be a bad thing; because

when I am there, despite everything, nothing comes out. Who knows, you may well have things to say to one another. But in any case one would scarcely believe that....your habits of smoking, for example, you know well, you see that plays a role, all of that! And then there are the people from administration also, because you know, in an affair like that, no one is missing. The admin staff said that I was receiving a strange group of people here (*laughter*) as such! It even appears that they had to repair the seats. Something happened! Jean-Jacques Lebel, you were not the one who was here with a band-saw? From time to time I heard a little noise, you must have been sawing the arms of the chairs!

One learns something every day! You are going to be able to fan yourself with that thing when I say goodbye to you in a moment! The smell on it will be substituted for the smoke.

What would be good, you see, is that you should give to this the only fate that it should really have worthy of what it is, a kind of signifier. You are going to find a sense for this word, *la Flacelière*. I for my part put that in the feminine like that; I would not say that this is a penchant but anyway it sounds rather feminine, the *cordelière*, or the *flatulencière*! What if this got into common usage, "do you take me for a *flacelière*? (*Laughter*).

That may be of use to you given the way things are happening! Do not pull too hard on the *flacelière*! I will leave you to find that. Me for my part I always taught that it is the signifiers that created the signifieds. That makes me dream a little. I realised a lot of things, in particular the complete ignorance of a certain use of paper that obviously could only happen when people had paper. Before that this was not done

with a parchment or with a papyrus! We do not know at what date, I telephone the mother houses as I might call them, nobody knows, when this use of paper began; in a flash, because it is a question that I had posed myself only in connection with chapter XIII of Gargantua. Someone could perhaps inform me about the subject. Anyway do not use it for that; I did not give you a package, I only gave you one each.

My dear friends, at this point I will leave you. I point out to you that these papers are signed, signed, actually I was not going to put my signature on the back of this paper, but I put the date. On 191 samples, this date is from my hand. On the 150 others, it is from the hand of my faithful secretary, Gloria, who was kind enough to substitute herself for me in that – you know it gives you a cramp. To write 25.6.69 151 times may well be very graphic, all the same I took the trouble.

On this, if you have some reflections to make to one another or some message to send to me, I will leave you in the hands of the faithful Gloria who is going to collect messages on this occasion. Anybody who would like to give an opinion in any way that seems opportune to him, has a good 20 minutes to do it.

As for me I will say adieu and thank you for your fidelity. (*Lively applause*).