

THE SEMINAR OF JACQUES LACAN

BOOK IX

Identification

1961 - 1962

Translated by Cormac Gallagher from unedited French typescripts

FOR PRIVATE USE ONLY

Seminar 1: Wednesday 15 November 1961

Identification - this is my title and my subject for this year. It is a good title but not an easy subject. I am sure you do not think that it is an operation or a process that is very easy to conceptualize. If it is easy to recognise, it would perhaps nevertheless be preferable, in order to recognise it correctly, for us to make a little effort in order to conceptualize it. It is certain that we have encountered enough of its effects even if we remain at something rather summary, I mean at things which are tangible, even to our internal experience, for you to have a certain feeling about what it is. This effort of conceptualization will appear to you, at least this year, namely a year which is not the first of our teaching, to be without any doubt justified retrospectively because of the places, the problems to which this effort will lead us.

Today we are going to take a very first little step in this direction. I apologise to you, this is perhaps going to lead us to make efforts which are properly speaking called efforts of thinking: this will not often happen to us, to us any more than to others.

If we take identification as the title, as the theme of our remarks, it would be well for us to speak about it otherwise than in what could be called the mythical form on which I left it last year. There was something of this order, of the order of (2) identification in particular, involved, you remember, in this point at which I left my remarks last year, namely where - as I might say - the humid layer with which you represent for yourselves the narcissistic effects which circumscribe this rock, what was left emerging from the water in my schema, this autoerotic rock whose emergence the phallus symbolises: an island in short battered by the waves of Aphrodite, a false island since moreover like the one in which Claudel's Proteus figures, it is an island without moorings, an island that is drifting away. You know what Claudel's Protee is. It is the attempt to complete The Orestia by the ridiculous farce which in Greek tragedy is obliged to complete it and of which there remains in the whole of literature only two pieces of jetsam by Sophocles and a Hercules by Euripedes, if I remember correctly.

It is not unintentionally that I am evoking this reference in connection with the fashion in which last year my discourse on transference ended on this image of identification. Try as I might I could not find a beautiful way to mark the barrier at

which transference finds its limit and its pivoting point. No doubt, this was not the beauty which I told you was the limit of the tragic, the point at which the ungraspable thing pours its euthanasia over us. I am embellishing nothing, whatever may be imagined from the rumours one sometimes hears about what I am teaching: I am not overdoing things for you. This is known to those who formerly listened to my seminar on Ethics, the one in which I exactly approached the function of this barrier of beauty under the form of the agony which the thing (la chose) requires of us for us to join it.

(3) Here then is where transference ended last[^]year. I indicated to you, to all of those who attended the Journées provinciales in October, I highlighted for you, without being able to say any more, that what we had here was a reference hidden in something comic which is the point beyond which I could not push any further what I was aiming at in a certain experience, an indication as I may say which is to be rediscovered in the hidden meaning of what one could call the cryptogrammes of this seminar, and after all I do not give up hope that a commentary will one day separate it out and highlight it, because moreover I happen to have heard a certain testimony which, in this regard is a sign of hope: it is that the seminar of the year before last, the one on ethics had effectively been taken up again - and according to those who have been able to read the work in a completely successful way - by someone who went to the trouble of rereading it in order to summarise the elements of it, I am talking about M. Safouan, and I hope that perhaps these things may be able to be put at your disposal fairly rapidly so that there can be linked onto them what I am going to bring you this year. Jumping from one year onto the second next one after it may seem to give rise to a question for you, or even to constitute a regrettable delay; this however is not altogether justified, as you will see if you take up this sequence of my seminars since 1953: the first on the technical writings, the one which followed on the ego: technique and Freudian psychoanalytic theory, the third on the Freudian structures of psychosis, the fourth on object relations, the fifth on the formations of the unconscious, the sixth on desire and its interpretation, then ethics, transference, identification at which we are arriving: that is nine, you can easily find in them an alternation, a pulsation, you will see that in every second one there dominates the thematic of the subject and that of the signifier, which, given that it was with the signifier, with the elaboration of the function of the symbolic that we began, makes us land this year also on the signifier because we are at an odd number, even though what is in question in identification ought to be properly the relationship of the subject to the signifier.

This identification then, which we propose to attempt to give an adequate notion of this year, has no doubt been rendered rather trivial for us by analysis; as someone who is rather close to me and understands me very well said to me, "so this year you are doing identification", and this with a pout: "the all-purpose explanation", allowing there to pierce through at the same time some disappointment about the fact in short that something rather

different was expected from me. Let this person be under no illusions. His expectation, in effect, of seeing me avoid the topic, as I might say, will be disappointed, because I hope indeed to treat it and I hope also that the fatigue which this topic suggests to him in advance will be dissolved. I will indeed speak about identification itself. In order to specify what I understand by that, I would say that when one speaks about identification what one thinks about first is the other to whom one is identified, and that the door is easily opened for me to put the accent, to insist on this difference between the other and the Other, between the small other and the big Other, which is a theme with which I may indeed say that you are already familiar.

It is not however from this angle that I intend to begin. I will put the accent rather on that which, in identification, poses (5) itself immediately as identical, as founded on the notion of the same, and even of the same to the same, with all the difficulties that this gives rise to.

You surely know and can even rather quickly spot what difficulties have always been presented for thinking by the following: $A = A$. Why separate it from itself in order to replace it there so quickly? What we have here is not purely and simply a jeu d'esprit. You can be sure, for example, that, along the line of a movement of conceptual elaboration, which is called logical-positivism, where one or other person strives to aim at a certain goal which would be, for example, that of not posing a logical problem unless it has a meaning that can be located as such in some crucial experiment, it would be decided to reject any logical problem whatsoever which could not in some way offer this final guarantee by saying that it is as such a meaningless problem.

It nevertheless remains that if Russell can give a value to these mathematical principles, to the equation, to the equivalence of $A = A$, someone else, Wittgenstein, opposes it because precisely of the impasses which seem to him to result from it in the name of the principles he starts with and that this refusal will even be set forth algebraically, such an equality requiring then a change of notation in order to find what can serve as an equivalent of the recognition of the identity A is A .

For our part, we are going, having posed the fact that it is not at all the path of logical-positivism which appears to us, in logical matters, to be in any way the one which is justified, to (6) question ourselves, I mean at the level of an experience of words, the one in which we put our trust despite its equivocations, even its ambiguities, about what we can tackle under this term of identification.

You are not unaware of the fact that one observes, in all tongues, certain rather general, even universal historical turning points so that one can speak about modern syntaxes opposing to them in a global way syntaxes which are not archaic, but simply ancient, by which I mean the tongues of what one can

call Antiquity. These sorts of general turning points, as I told you, are those of syntax. It is not the same with the lexicon where things are much more changeable; in a way each tongue contributes, as compared to the general history of language, vacillations which are proper to its own genius and which render one or other of them more propitious for highlighting the history of a meaning. Thus it is that we can pause at what is the term, or the substantival notion of the term, of identity (in identity, identification, there is the Latin term idem), and this will go to show you that some significant experience is supported in the common French term, which is the support of the same signifying function, that of the meme. It seems, in effect, that it is the em, the suffix of i in idem, in which we find operating the function, I would say of the radical in the evolution of Indo-European at the level of a certain number of italic tongues; this em is here redoubled, an ancient consonant which is rediscovered then as the residue, the remainder, the return to a primitive thematic, but not without having collected in passing the intermediate phase of etymology, positively of the birth of this theme which is a commonplace Latin met ipsum, and even a (7) metipsissimum from the expressive low Latin, pushes us then to recognise in what direction here experience suggests we should search for the meaning of all identity, at the heart of what is designated by a sort of redoubling of moi-meme, this myself being, as you see, already this metipsissimum, a sort of au jour of aujourd'hui which we do not notice and which is indeed there in the moi-meme.

It is then in an metipsissimum that there are afterwards engulfed the me, the thou, the he, the she, the them, the we, the you and even oneself, which happens then in French to be a soi-meme. Thus we see there, in short in our tongue a sort of identification through the operation of a special significant tendency, that you will allow me to qualify as "mihilisme" in so far as to this act, this experience of the ego is referred.

Naturally, this would only have an incidental interest if we were not to rediscover in it another feature in which there is revealed this fact, this difference which is clear and easy to locate if we think that in Greek, the auton of the self is the one which serves to designate also the same, just as in German and in English the selbst or the self will come into play to designate identity. Therefore I do not believe that it is for nothing that we pick up here and that we interrogate this kind of permanent metaphor in the French expression. We will allow it to be glimpsed that it is perhaps not unrelated to what happened at a quite different level: that it should have been in French, I mean in Descartes, that being was able to be thought of as inherent in the subject, in a mode in short which we will describe as captivating enough to ensure that ever since the formula was proposed to thought, one might say that a good share (8) of the efforts of philosophy consists in trying to extricate oneself from it, and in our own day in a more and more open fashion, there being, as I might say, no thematic of philosophy which does not begin, with some rare exceptions, by trying to master this famous: "I think therefore I am".

I believe that for us it is not a bad point of entry for this "I think therefore I am" to mark the first step of our research. It is understood that this "I think therefore I am" is on the path taken by Descartes. I thought of indicating it to you in passing, but I will tell you right away: it is not a commentary on Descartes that I can try to tackle today in anyway whatsoever, and I have no intention of doing it. The "I think therefore I am", naturally if you referred to Descartes' text is, both in the Discourse and in the Meditations, infinitely more fluid, more slippery, more vacillating than this kind of lapidary expression with which it is marked, both in your memory and in the passive or surely inadequate idea that you may have of the Cartesian process. (How would it not be inadequate because moreover there is not a single commentator who agrees with another one as regards its exact sinuosity).

It is therefore arbitrary to some extent, and nevertheless there are reasons enough for it, the fact is that this formula which has a meaning for you and has a weight which certainly goes beyond the attention that you may have granted it up to now, I am going today to dwell on it in order to show a kind of introduction that we can rediscover in it. It is a question for us, at the point of the elaboration that we have arrived at, of (9) trying to articulate in a more precise fashion something that we have already advanced more than once as a thesis: that nothing supports the traditional philosophical idea of a subject, except the existence of the signifier and its effects.

Such a thesis, which as you will see will be essential for every incarnation that we will subsequently be able to give to the effects of identification, requires that we should try to articulate in a more precise fashion how effectively we conceive of this dependence of the formation of the subject on the existence of the effects of the signifier as such. We will even go further by saying that if we give to the word thinking a technical meaning: the thinking of those whose trade is thinking, one can, by looking closely at it, and in a way retrospectively, perceive that nothing of what is called thinking ever did anything other than to position itself somewhere within this problem.

From this, we will state that we cannot say that, at the very least, we contemplate thinking only, in a certain fashion, whether we wish it or not, whether you knew it or not, every research into, every experience of the unconscious, which we have on this occasion about what this experience is, is something which is placed at this level of thinking where, in so far as we are no doubt going there together, but not all the same without me leading you there, the tangible relationship which is the most present, the most immediate, the most incarnated of this effort, is the question that you can pose yourselves in this effort about the "who am I?".

What we have here is not an abstract philosophical game: for, on the subject of "who am I?" what I am trying to initiate you into, you doubtless know - at least some of you - that I mean it in

(10) every possible sense. Those who know it may be, naturally, those from whom I hear it, and I am not going to embarrass anyone by publishing here what I hear of it. Moreover, why would I do it since I am going to grant you that the question is a legitimate one? I can lead very far along this track without there being guaranteed for you for a single instant the truth of what I am telling you, even though in what I am telling you there is never a question of anything but of the truth and, in what I hear of it, why not say after all that this carries over into the dreams of those who address themselves to me. I remember one of the them - one can quote a dream -: "Why?", dreamt one of my analysands, "does he not tell the truth about the truth?".

I was the one in question in this dream. This dream ended up nevertheless with my subject in a fully awake state complaining to me about this discourse in which, according to him, the last word was always missing. It does not resolve the question to say: you are children who are always wanting to believe that I am telling you the real truth (la vraie verite*): because this term, the real truth, has a meaning, and I would further say: it is on this meaning that the whole credit of psychoanalysis has been built. Psychoanalysis presented itself at first to the world as being that which brought the real truth. Naturally, one falls quickly into all sorts of metaphors which allow the thing to escape. This real truth is what is concealed. There will always be one, even in the most rigorous philosophical discourse: it is on this that there is founded our credit in the world and the stupefying thing is that this credit still persists even though, for a good while now, not the least effort has been made to give even the slightest start to something which would respond to it.

(11) Under these circumstances I feel myself quite honoured to be questioned on this theme: "where is the real truth of your discourse?". And I can even, after all, find that it is precisely indeed in so far as I am not taken for a philosopher, but for a psychoanalyst, that I am posed this question. Because one of the most remarkable things in philosophical literature, is the degree to which among philosophers, I mean in so far as they are philosophising, when all is said and done the same question is never posed to philosophers, unless it is to admit with a disconcerting facility that the greatest of them have never thought a word of what they have communicated to us in black and white and allowed themselves to think in connection with Descartes, for example, that he had only the most uncertain faith in God because this suits one or other of his commentators unless it is the opposite that suits him.

There is one thing, in any case, which has never seemed to shake for anyone the credit of philosophers, which is that it has been possible to speak, with respect to each of them, and even the greatest, about a double truth. That then I who, entering into psychoanalysis, put my feet in the platter by posing this question about truth, should suddenly feel the aforesaid platter getting warm under the soles of my feet, is something about which after all I can rejoice, since, if you reflect on it, I am all the same the one who turned on the gas. But, let us leave this

now, let us enter into the identity-relationships of the subject, and let us enter into it through the Cartesian formula and you are going to see how I intend to tackle it today.

It is quite clear that there is absolutely no question of pretending to go beyond Descartes, but rather indeed to draw the (12) maximum effect from the utilization of the impasses whose foundation he connotes for us. If you follow me then in a critique which is not at all a textual commentary, you should clearly remember what I intend to take from it for the good of my own discourse. "I think therefore I am" appears to me under this form to go against common usages to the point of becoming this worn down money without a figure that Mallarmé makes an allusion to somewhere. If we hold onto it for a moment, and try to polish up its sign function, if we try to reanimate its function for our purposes, I would like to remark the following: the fact is that this formula, which I repeat is only found in its concentrated form in Descartes at certain points of the Discours de la Methode, it is not at all in this way in this dense form that it is expressed. This "I think therefore I am", encounters this objection - and I believe that it has never been made - which is that "I think" is not a thought. Descartes, of course, proposes these formulae at the end of a long process of thinking, and it is quite certain that the thinking involved is the thinking of a thinker. I would go even further: this characteristic, it is a thinking of a thinker, is not required for us to talk about thought. A thought, in a word, in no way requires that one thinks about the thought.

For us in particular, thinking begins with the unconscious. One cannot but be astonished at the timidity which makes us have recourse to the formula of psychologists when we are trying to say something about thinking, the formula of saying that it is an action at the state of being outlined, at a reduced state, the small economic model of action. You will tell me that you can find that somewhere in Freud, but of course, one can find (13) everything in Freud: in some paragraph or other he may have made use of this psychological definition of thinking. But after all, it is extremely difficult to eliminate the fact that it is in Freud that we also discover that thinking is a perfectly efficacious mode, and in a way one that is sufficient to itself, of masturbatory satisfaction? This to say that, as regards what is in question concerning the meaning of thinking, we have perhaps a slightly broader span than other workers. This does not exclude that in questioning the formula we are dealing with: "I think therefore I am", we could say that, as regards the use that is made of it, it cannot but pose us a problem: because we have to question this word "I think", however large may be the field that we have reserved for thinking, to see the characteristics of thinking being satisfied, to see being satisfied the characteristics of what we can call a thinking. It could be that this word proved itself quite insufficient to sustain in any way, anything whatsoever that we may at the end discover of this presence: "I am".

This is precisely what I am claiming. To clarify my account, I

would point out the fact that "I think" taken simply in this form, is logically no more sustainable, no more supportable than the "I am lying", which has already created problems for a certain number of logicians, this "I am lying" which can only be sustained because of the no doubt empty but sustainable logical vacillation which this apparent meaning unfolds, quite sufficient moreover to find its place in formal logic. "I am lying", if I say it, it is true, therefore I am not lying, but nevertheless I am indeed lying because in saying "I am lying" I affirm the contrary.

(14) It is very easy to dismantle this so-called logical difficulty and to show that the so-called difficulty on which this judgment reposes depends on the following: the judgement that it involves cannot refer to its own enunciation, it is a collapsing: it is on the absence of distinction between two planes, because of the fact that the accent is put on the "I am lying" itself without making a distinction in it, that this pseudo-difficulty comes about; this in order to tell you, that without this distinction, we are not dealing with a real proposition.

These little paradoxes, of which the logicians make a great deal, in order moreover to reduce them immediately to their proper measure, may seem to be simple amusements: they have all the same their interest: they should be retained in order to pinpoint in short the true position of all formal logic, up to and including this famous logical-positivism of which I spoke earlier. By that I mean that in my opinion not enough use precisely has been made of the famous aporia of Epimenides - which is only a more developed form of what I have just presented to you in connection with the "I am lying" - that "All Cretans are liars". Thus speaks Epimenides the Cretan, and you immediately see the little whirligig that is engendered. Not enough use has been made of it to demonstrate the vanity of what is called the famous universal affirmative proposition A. Because in effect, one notices it in this connection, it is indeed here, as we will see, the most interesting form for resolving the difficulty. Because, observe carefully what happens, if one poses the following which is possible, which has been posed in the criticism of the famous universal affirmative A of which some people have claimed, not without foundation, that its substance has never been other than that of a universal negative proposition "there is no Cretan who (15) is not capable of lying", from then on there is no longer any problem. Epimenides can say it, for the reason that expressed in this way he does not say at all that there is someone, even a Cretan who is able to lie in a continuous stream, especially when one notices that tenaciously lying implies a sustained memory which ensures that it ends up by orienting the discourse in the sense of being the equivalent of an admission, so that, even if "all Cretans are liars" means that there is no Cretan who does not wish to lie in a continuous stream, the truth indeed will finish up by escaping him and, in the precise measure of the rigour of this will; the most plausible meaning of the avowal by the Cretan Epimenides that all Cretans are liars, this meaning can only be the following, which is that:

- 1) he glories in it
- 2) he wants by that to unsettle you by really warning you about his method; but this has no other intention, this has the same success as this other procedure which consists in announcing that one is oneself a plain blunt man, that one is absolutely frank. This is the type who suggests to you that you should endorse all his bluffing.

What I mean, is that every universal affirmative, in the formal sense of the category, has the same oblique goals, and it is very interesting to see these goals manifesting themselves in the classical examples. That it should be Aristotle who takes the trouble to reveal that Socrates is mortal should all the same inspire some interest in us, which means offer an opening for what we can call among ourselves an interpretation, in the sense that this term claims to go a little further than the function which is found precisely in the very title of one of the books of Aristotle's Logic. Because if obviously it is qua human animal that he whom Athens names Socrates is assured of death, it is all (16) the same well and truly in so far as he is named Socrates that he escapes from it, and this obviously not alone because his renown still endures for as long as there lives the fabulous transference operation operated by Plato, but again more specifically because it is only as having succeeded in constituting himself, beginning from his social identity, as this atypical being which characterises him, that the person called Socrates, the one so named in Athens - and that is why he could not go into exile - was able to sustain himself in the desire of his own death even to the extent of making of his life an acting out of it. There is also to be added this final touch of settling up for Asclepios¹ famous cock of which there would be question if the recommendation had to be made of not doing any harm to the chestnut-seller at the corner.

There is therefore here, in Aristotle, something which we can interpret as some sort of attempt precisely to exorcise a transference which he believed to be an obstacle to the development of knowledge. It was moreover an error on his part since its failure is obvious. It would have been surely necessary to go a bit further than Plato in the denaturing of desire for things to have ended up otherwise. Modern science is born in a hyper-Platonism and not at all in the Aristotelian return to, in short, of the function of knowledge according to the status of the concept. It required, in fact, something which we can call the second death of the Gods, namely their ghostly re-emergence at the time of the Renaissance, for the word to show us its real truth, the one which dissipates, not the illusions, but the obscurities of meaning from which modern science emerged.

(17) Therefore - as we have said - this sentence of: "I think" has the interest of showing us - it is the least that we can deduce from it - the voluntary dimension of judgement. We have no need to say that much about it: the two lines that we distinguish as enunciating and enunciation are sufficient to allow us to affirm that it is in the measure that these two lines are mixed up and confused that we find ourselves before a

paradox which culminates in this impasse of the "I am lying" on which I made you pause for an instant; and the proof that this is really what is in question, is the fact that I can at the same time lie and say in the same voice that I am lying; if I distinguish these voices it is quite admissable. If I say: he says I am lying, that is easily admitted, there is no objection to it, anymore than if I said: he is lying, but I can even say I say I am lying.

There is all the same something here which ought to retain us, it is that if I say "I know that I am lying", this has again something quite convincing which ought to retain our attention as analysts since, precisely as analysts, we know that what is original, living and gripping in our intervention is the fact that we can say that we are there to speak, to displace ourselves in the exactly opposite but strictly correlative dimension which is to say: "but no, you do not know that you are telling the truth", which immediately goes much further. What is more: "you only tell it so well in the measure that you think you are lying and when you do not want to lie it is to protect yourself from that truth".

(18) It seems that one cannot reach this truth except through these glimmers, the truth is a girl in this - you recall our terms - that like any other girl it can be nothing but a stray, well, it is the same for the "I think". It appears indeed that if it has such an easy run among those who spell it out or who re-broadcast its message, namely the professors, that can only be by not dwelling too much on it. If we have for the "I think" the same exigencies as for the "I am lying", either indeed this means: "I think that I am thinking", which is then absolutely to speak of nothing other than the "I think" of opinion or imagination, the "I think" in the way you say it when you say "I think she loves me" which means that trouble is on the way.

Following Descartes, even in the text of the Meditations, one is surprised at the number of incidences in which this "I think" is nothing other than this properly imaginary dimension on which no so-called radical proof can be founded. Or indeed then this means: "I am a thinking being" - which is, of course, to upset in advance the whole process for what is aiming precisely at making emerge from the "I think" an unprejudiced status, not infatuated as it were by my own existence. If I begin by saying: "I am a being", that means: I am of course a being essential to being, there is no need to throw out anything else, one can preserve one's thinking for one's personal use.

This having been highlighted, we find ourselves encountering something which is important: we find ourselves encountering this level, this third term that we raised in connection with the I am lying, namely that one could say: "I know that I am lying", and this is something which should retain you. In effect, this indeed is the support of everything that a certain phenomenology has developed concerning the subject, and here I putting forward a formula which is one on which we will be led to begin again on the next occasions, which is the following: what we are dealing

with, and how this is given us since we are psychoanalysts, is to radically subvert, to render impossible this most radical prejudice, and therefore it is the prejudice which is the true support of this whole development of philosophy, which one can say is the limit beyond which our experience has gone, the limit beyond which there commences the possibility of the unconscious.

The fact is that there has never been, in the philosophical lineage which has developed from what are called the Cartesian investigations into the cogito, that there has never been but a single subject which I would pinpoint, to terminate, under^this form: the subject who is supposed to know (le sujet suppose savoir). You should here provide this formula with the special resonance which, in a way, carries with it its irony, its question, and notice that by referring it to phenomenology and specifically to Hegelian phenomenology, the function of the subject who is supposed to know takes on its value by being appreciated in terms of the synchronic function which is deployed in this connection: its presence always there, from the beginning of phenomenological questioning, at a certain point, at a certain knot of the structure, will allow us to extricate ourselves from the diachronic unfolding which is suppose to lead us to absolute knowledge.

This absolute knowledge itself - as we will see in the light of this question - takes on a singularly refutable value, but today only in this: let us stop ourselves from posing the motion of (20) distrust at attributing this supposed knowledge to anyone whatsoever, or of supposing (subjicere) any subject of the knowledge. Knowledge is intersubjective, which does not mean that it is the knowledge of all, nor that it is the knowledge of the Other - with a capital O - and the Other we have posed. It is essential to maintain it as such: the Other is not a subject, it is a locus to which one strives, says Aristotle, to transfer the knowledge of the subject.

Naturally, of these efforts there remains what Hegel unfolded as the history of the subject; but this does absolutely not mean that the subject knows a whit more about what he is returning from. He is only stirred, as I might say, in function of an unfounded supposition, namely that the Other knows that there is an absolute knowledge, but the Other knows even less about it than he, for the good reason precisely that it is not a subject. The Other is the refuse dump of the representative representations of this supposition of knowledge, and this is what we call the unconscious in so far as the subject has lost himself in this supposition of knowledge. He drags it (ca) along without his being aware of it, it is the debris that comes back to him from what his reality undergoes in this thing, a more or less unrecognisable debris. He sees it coming back, he can say or not say: it is indeed that or indeed it is not at all that: all the same it is altogether it.

The function of the subject in Descartes, it is here that we will take up our discourse the next time, with the resonances of it that we find in analysis. We will try, the next time, to map out

the references to the phenomenology of obsessional neurosis in a signifying scansion in which the subject finds himself immanent in every articulation.

Seminar 2: Wednesday 22 November 1961

You have been able to see, to your satisfaction, that I was able to introduce you the last time to the remarks we are going to make this year by means of a reflection which, in appearance, might have seemed to be a rather philosophical one because it dealt precisely with a philosophical reflection, that of Descartes, without it giving rise on your part, it seems to me, to too many negative reactions. Far from it, it seems that I have been trusted as regards the legitimacy of what might follow from it. I am delighted at this feeling of confidence which I would like to be able to translate as saying that you at least sensed where I wanted to lead you by that.

Nevertheless, so that you may not develop, from the fact that I am going to continue today on the same theme, the feeling that I am delaying, I would like to pose that such indeed is our goal, in this mode that we are tackling, to engage ourselves on this path. Let us say it right away, in a formula which all our future development will subsequently clarify: what I mean is that, for us analysts what we understand by identification - because this is what we encounter in identification, in what is concrete in our experience concerning identification - is a signifier-identification (une identification de signifiant).

Reread in the Course in Linguistics one of the numerous passages where de Saussure tries to get closer to, as he continuously (2) tries to do by circumscribing it, the function of the signifier, and you will see (I am saying this in parenthesis) that all his efforts did not finally avoid leaving the door open to what I would call less differences of interpretation than veritable divergences in the possible exploitation of what he opened up with this distinction which is so essential of signifier and signified. Perhaps I could touch on it in passing for you so that you can at least note the existence, the difference there is between one school and another: that of Prague, to which Jakobson, to whom I so often refer, belongs and that of Copenhagen to which Hjelmslev gave its orientation under a title which I have never yet evoked before you, that of Glossematics.

You will see: it is almost bound to happen that I will be led to come back to it because we cannot take a step without trying to deepen this function of the signifier, and consequently its relationship to the sign.

You ought all the same to know already - I think that even those among you who might have believed, even to the extent of reproaching me for it, that I was repeating Jakobson - that in fact, the position which I take up here is in advance of, ahead of that of Jakobson as regards the primacy which I give to the function of the signifier in every realisation, let us say, of the subject. The passage of de Saussure, to which I alluded earlier - I am only privileging it here because of its value as an image - is the one in which he tries to show what sort of identity that of the signifier is by taking the example of the (3) 10.15 express. The 10.15 express, he says, is something perfectly defined in its identity: it is the 10.15 express despite the fact that obviously the different 10.15 expresses, which succeed one another in an always identical way every day, have absolutely nothing either in their material, indeed even in the composition of the train, but indeed a different real structure and components.

Of course, what is true in such an affirmation supposes precisely, in the constitution of a being like the 10.15 express, a fantastic interlinking of signifying organisation entering into the real through the mediation of spoken beings. It remains that this has in a way an exemplary value, in order to well define what I mean when I put forward first what I am going to try to articulate for you: these are the laws of identification qua signifier identification. Let us even highlight, as a reminder, that to remain with an opposition which is a sufficient support for you, what is opposed to it, what it is distinguished from, what makes it necessary that we should elaborate its function, is that the identification that it thus distances itself from is that of the imaginary, the one whose extreme form I tried to show you a long time ago in the background of the mirror stage in what I would call the organic effect of the image of our fellows, the effect of assimilation that we grasp at one or other point of natural history, and the example which I was happy to show in vitro under the form of this little animal, which is called the migratory locust, and of whom you know that the evolution, the growth, the apparition of what is called the totality of the (4) phaneres, of the way in which we can see it - depends in its form in some way on an encounter which happens at one or other moment of its development, of the stages, of the phases of the larval transformation or according to whether there have appeared to it or not a certain number of traits of the image of its fellow, it will evolve or not, in different cases, according to the form which is called solitary or the form which is called gregarious.

We do not know everything, we even know rather little about the stages of this organic circuit which bring with them such effects. What we do know is that it is experimentally certain. Let us classify it under the general rubric of the effects of the image of which we will find all sorts of forms at very different levels of the physical and even the inanimate world, as you know, if we define the image as any physical arrangement which has as a result the constitution between two systems of a bi-univocal concordance, at whatever level it may be.

It is a very conceivable formula, and one which can be applied just as much to the effect that I have just mentioned, for example, as to that of the formation of an image, even a virtual one, in nature through the mediation of a plane surface, whether it be that of a mirror or of the one that I have for a long time evoked, of the surface of the lake which reflects the mountain.

Does that mean that, as is the tendency and a tendency which is expanding under the influence of a kind, I would say, of intoxication, which recently took hold of scientific thinking from the fact of the irruption of what is only at bottom the (5) discovery of the dimension of the signifying chain as such but which, in all sorts of ways, is going to be reduced by this thinking to more simple terms - and very precisely this is what is expressed in what are called information theories - does this mean that it is correct, without any other connotation, for us to resolve to characterize the liaison between the two systems, one of which is an image with respect to the other, by this idea of information, which is very general, implying certain paths taken by this something which carries the bi-univocal concordance?

This indeed is where there exists a very great ambiguity, I mean the one which can only end up by making us forget the proper levels of what information should involve if we want to give it a value other than the vague one which would only end up when all is said and done by giving a sort of re-interpretation, a false consistency to what had up to then been subsumed, and this from Antiquity up to our own day, under the notion of the form, something which captures, envelopes, determines the elements, gives them a certain type of finality which is the one that in the whole ascension from the elementary towards the complex, from the inanimate towards the animate, is something which has no doubt its enigma and its own value, its order of reality, but which is distinct.

If this is what I intend to articulate here with all the force of the new things that are brought to us, in the new scientific perspective, by the highlighting, the separating out of what is contributed by the experience of language and of what the signifier relationship allows us to introduce as an original dimension that it is a matter of radically distinguishing from the real in the form of the symbolic dimension, it is not, as you see, in this way that I am tackling the problem of what is going (6) to allow us to split up this ambiguity.

Already all the same I have said enough about it for you to know, for you to have sensed, apprehended, in these elements of signifying information, the originality that is contributed by the trait, let us say, of seriality, that they involve, the trait also of discreteness, I mean of cutting, something which Saussure in no way better articulated than by saying that what characterizes them with regard to one another, is to be what the others are not.

Diachrony and synchrony are the terms to which I pointed out you should refer, even though all of this is not fully articulated.

the distinction having to be drawn with this de facto diachrony: too often it is simply what is aimed at in the articulation of the laws of the signifier. There is a rightful diachrony through which we rejoin the structure; in the same way for synchrony, one is not saying everything about it, far from it, by implying in it the virtual simultaneity of the code in each supposed subject, because that is to rediscover here something which I showed you the last time is for us an entity which is untenable. I mean that we cannot be satisfied in any way with having recourse to it, because it is only one of the forms of what I denounced at the end of my discourse the last time under the name of the subject who is supposed to know. Here is why this year I am beginning my introduction to the question of identification in this way, the fact is that it is a question of starting from the very difficulty, from the one which is proposed to us by the very fact of our experience, from what it begins with, from that which as a starting point we must articulate it, theorise it; the fact is that we cannot, even in terms of our aims, of a future promise, in any way refer ourselves, as Hegel did, to any (7) possible termination, precisely because we have no right to pose it as possible for the subject in some sort of absolute knowledge or other.

We must learn at every moment to dispense with this subject who is supposed to know. We cannot at any moment have recourse to it, this is excluded: through an experience which we already have since the seminar on desire and on interpretation (the first trimester which was published) it is very precisely what seemed to me in any case could not be omitted from this publication, because this is the term of a whole phase of this teaching that we gave: the fact is that this subject of ours, this subject which I would like today to interrogate for you in connection with the Cartesian way forward, is the same one that in this first trimester I told you we could not approach any closer than is done in this exemplary dream which is entirely articulated around the sentence: "he did not know that he had died".

To be absolutely rigorous, it is indeed there, contrary to the opinion of Politzer that we can designate the subject of enunciating, but in the third person. This is not to say, of course, that we could not approach it in the first person, but this would be precisely to know that in doing so, and in the most pathetically accessible experience, it slips away, because by translating it into this first person, it is precisely at this sentence that we will end up: by saying what we can say precisely, in the practical measure that we can confront ourselves with time's chariot, as John Donne [sic] says "hurrying near": it is at our heels, and in this pause in which we can foresee the ultimate moment, the one precisely at which already (8) everything will leave us, to say to ourselves: "I did not know that I was living as a mortal being, (je ne savais pas que je vivais d'etre mortel)".

It is quite clear that it is in the measure that we can say to ourselves that we have forgotten it at almost every instant that we will be placed in this uncertainty, for which there is no

name, either tragic, or comic, of being able to say to ourselves, at the moment of leaving our lives that we have always been in a certain measure strangers to our own lives. This indeed is what is at the bottom of the most modern philosophical interrogation, that through which, even for those who as I might say are only very little fettered by it, even those very people who proclaim their feelings about this obscurity, all the same something is happening, whatever may be said about it, something different is happening than the popularity of a fashion in the formula of Heidegger recalling us to the existential foundation of being for death. Whatever its causes may be, whatever its correlations, or even its impact - one can say - what one can call the profanation of the great phantasies forged for desire by the style of religious thinking is not a contingent phenomenon, this mode of thinking is here what will leave us uncovered, disarmed, giving rise to this hollow, this void, to which this modern philosophical meditation strives to respond, and to which our experience has also something to contribute, because this is its place, at the instant that I am designating sufficiently for you the same place at which this subject constitutes himself as not being able to know precisely why there is a question for him here of the All.

This is the value of what Descartes brings us, and that is why it was good to start with him.

(9) That is why I am coming back to it today, because it is appropriate to go over it again in order to measure again what is involved in what you were able to hear me designating for you as an impasse, namely the impossibility (l'impossible) of the "I think therefore I am".

It is precisely this impossibility which gives its price and its value to this subject which Descartes proposes to us, even if it is only the subject around which the age-old cogitations turned before, turn since, it is clear that our objections in our last discourse take their weight, the very weight implied in the etymology of the French verb penser which means nothing other than peser (to weigh). What can be based on the "I think", if we know, we analysts, that this "what I am thinking about" which we may grasp, refers back to a "from which and from where I think" which necessarily slips away; and this is indeed why Descartes' formula questions us to know whether there is not at least this privileged point of the pure "I think" on which we might base ourselves, and this is why it was at the very least important that I should make you pause for an instant. This formula seems to imply that it would be necessary for the subject to be careful to think at every instant in order to assure himself of being. Is it sufficient for him to think that he is for him to touch this thinking being? For it is indeed on that that Descartes, in this incredible magic of the discourse of the two first meditations, suspends us. He manages to make stand up, I mean in his text, not that once the professor of philosophy has picked out its signifier and shown too easily the artifice which results from formulating that in thinking thus I can say that I am a thing which thinks - it is too easy to refute - but which

takes nothing from the force of the progress of the text, except (10) for the fact that we must interrogate this thinking being, ask ourselves if it is not the participle of an être-penser (to be written in the infinitive and in a single word): j' 'être-pense, as one says j'outrecuide (I overween), as our analytic habits make us say "I compensate (je compense), even I decompensate, I overcompensate". It is the same term and just as legitimate in its composition. From then on, the "je pense-être" which is proposed to us to introduce us to it, may appear, in this prospective, an artifice that is hard to tolerate because moreover to formulate things in this way, the being already determines the register in which I inaugurate my whole progress; this "je pensetre" - as I told you the last time - cannot even in Descartes' text, be connoted except with traits of lure and appearance. "Je pensêtre" does not bring with it any greater consistency than that of dreams at which effectively Descartes at several moments of his progress has left us suspended. The "je pensetre" can for its part also be conjugated like a verb, but it does not go very far: "je pensêtre, tu pensêtres, with l's if you wish at the end, that may still be allowable, even "il pensêtre". All that we can say is that if we make of it the tenses of the verb with a sort of infinitive of "pensêtrer", we can only connote it with what is written in dictionaries that all the other forms, except the third person singular of the present, are not used in French. If we want to be humourous we will add that they are supplemented ordinarily by the same form of the verb complementary to pensêtrer: the verb s'empêtrer (to become entangled). What does that mean? The fact is that the act of êtrepenser - because this is what is in question - only ends up for whoever is thinking with a "peut-être je, perhaps I", and (11) moreover I am not the first nor the only one to have always remarked the contraband trait of the introduction of this "I" into the conclusion "I think therefore I am". It is quite clear that this "I" remains problematic and that until Descartes' next step - and we are going to see which one - there is no reason why it should be preserved from the total putting into question that Descartes carries out of the whole process by profiling at the foundations of this process the function of the deceitful God - you know that he goes further: the deceitful God is still a good God: in order to be there, to swamp me with illusions, he goes so far as to be an evil demon, a radical liar, the one who leads me astray in order to lead me astray: this is what has been called hyperbolic doubt. It can in no way be seen how this doubt has spared this "I" and leaves it therefore properly speaking in a fundamental vacillation.

There are two ways of articulating this vacillation: the classical articulation, the one which is already found - I rediscovered it with pleasure - in Brentano's psychology, the one which Brentano refers quite rightly to Saint Thomas Aquinas, namely that being cannot be grasped as thought except in an alternating fashion. It is in a succession of alternating moments that he thinks, that his memory appropriates its thinking reality without this thinking being at any moment able to join up with itself in its own certainty.

The other method, which is the one that brings us closer to the Cartesian approach, is for us to perceive precisely the properly speaking vanishing character of this "I", to make us see that the real meaning of the first Cartesian approach is to articulate (12) itself as an "I think and I am not". Of course, one can delay at the approaches of this assumption and perceive that I spend all the being I may have in thinking. Let it be clear that in the final analysis it is by stopping thinking that I can glimpse that I quite simply am; these are only approaches. The "I think and I am not" introduces for us a whole series of remarks, precisely some of those which I spoke to you about the last time concerning French morphology, first of all that about this "I", so much more dependent in our tongue in its form on the first person than in English or in German, for example or Latin where to the question "who did it?" you can reply: I, Ich, ego, but not je in French, but "c'est moi" or "pas moi". But je is something different, this je so easily elided in speech thanks to what are called the muted properties of its vocalisation, this je which can be a ch'sais pas (don't know), namely that the e disappears, but "ch'sais pas" is something different - you can really sense it because you are among those who have an original experience of French - to the "je ne sais" the ne of the "je ne sais" is brought to bear not on the sais (know) but on the je. That is also why that, contrary to what happens in these neighbouring tongues to which, without going any further, I allude for the moment, it is before the verb that there is brought to bear this decomposed part - let us call it that for the moment - of the negation which is the ne in French. Of course, the ne is neither proper to French, nor unique: the Latin ne presents itself for us with all the same problematic, which moreover I am here only introducing and to which we will return.

(13) As you know, I already alluded to what Pichon in connection with negation in French contributed to it by way of indications. I do not think - and this is not new either, I indicated it to you at the same time - that Pichon's formulations about the forclosive or the discordant can resolve the question, even though they introduce it in an admirable way.

But the closeness, the natural linkage in the French sentence of the je with the first part of the negation, "je ne sais" is something which enters into the register of a whole series of concordant facts, around which I signal to you the interest of the particularly significant emergence in a certain linguistic usage of problems which refer to the subject as such in his relationships to the signifier.

What I want to get to then is the following: it is that if we find ourselves more easily than others put on our guard against this mirage of absolute knowing, one which can already be sufficiently refuted by translating it into the satiated repose of a sort of colossal seventh day on this Sunday of life where the human animal will finally be able to feed his face with grass, the great machine being finally regulated down to the last carat of this materialised nothingness which the conception of knowledge is. Naturally, the human being will finally have found

his share and his reservation in his henceforth definitively cradled stupidity, and it is supposed that at the same time there will be torn away with this thinking excrescence its peduncle, namely worry.

But this, at the rate there are going things which are constructed, despite their charm, to evoke that there is there (14) something rather close to what we are dealing with I must say much more fantasy and humour: these are the various playthings of what is commonly called science fiction, which show in connection with this theme that all sorts of variations are possible.

In this respect, naturally, Descartes does not appear in such a bad light. If one may perhaps deplore that he did not know much more about these perspectives on knowledge it is in this respect alone that if he had known more about them, his morality would not have fallen so short. But apart from this trait which we leave here provisionally to one side for the value of his initial approach very far from that, there results something quite different.

The professors, in connection with Cartesian doubt, spend a lot of time underlining that it is methodical. They attach enormous importance to it: methodical, that means doubt that is cold. Naturally, even in a certain context, cold meals were consumed; but, in truth, I do not believe that this is the correct way to consider matters, not that I want in any way to encourage you to consider Descartes as a psychological case, however exciting it may appear to rediscover in his biography in the conditions of his kin, indeed of his descendants, some of these traits which, collected together, may make up a figure, by means of which we rediscover the general characteristics of psychasthenia, even to swallow up in this demonstration the celebrated passage about human coat hangers, these sorts of marionnettes around which it seems possible to restore a presence which, thanks to the whole detour of his thought, one sees precisely at this very moment in the process of being unfolded, I do not see any great interest in (15) it. What is important for me is that after having tried to make you sense that the Cartesian thematic is logically unjustifiable, I can reaffirm that it is not for all that irrational, it is no more irrational than desire is irrational because it is not articulatable simply because it is an articulated fact, as I believe is the whole meaning of what I have been demonstrating to you for a year to show you how it is.

Descartes' doubt, it has been underlined, nor am I the first to do it, is of course a doubt which is very different to sceptical doubt. Compared to Descartes' doubt, sceptical doubt entirely unfolds at the level of the question of the real. Contrary to what is believed he is far from putting it in question, he brings back, he reassembles his world in it, and some sceptic or other whose whole discourse reduces us to no longer holding anything to be valid except sensation, does not make it disappear for all that, he tells us that it has more weight, that it is more real than anything that we can construct in connection with it. This

sceptical doubt has its place, as you know, in Hegel's Phenomenology of the spirit: it is a moment of this research, of this quest in which knowing is engaged with respect to itself, this knowing which is only an not-yet-knowing, therefore, which because of this fact is an already-knowing. This is not at all what Descartes attacks. Descartes has no place in the Phenomenology of the spirit, he puts the subject himself in question and, even though he does not know it, it is the subject who is supposed to know that he is dealing with; it is not a matter for us of recognising ourselves in what the spirit is capable of, it is the subject himself as an inaugural act that is in question. This is, I believe, what gives its prestige, what (16) gives its fascinating value, what constitutes the turning-point effect that this senseless approach of Descartes effectively had in history, it is that it has all the characteristics of what we call in our vocabulary an impulsive action (un passage a l'acte). The first phase of Cartesian meditation has the mark of an impulsive act. It situates itself at this necessarily inadequate, and at the same time necessarily primordial stage, the whole attempt having the most radical, the most original relationship to desire, and the proof is indeed what he is led to in the step on God which immediately follows. What immediately follows, the step of the deceitful God, what is it?

It is the appeal to something that, to contrast it with the previous proofs, which naturally are not to be cancelled out, of the existence of God, I would allow myself to oppose as the verissimum to the entissimum. For St. Anselm, God is the most being of beings. The God we are dealing with here, the one whom Descartes brings in at this point of his thematic, is the God who must guarantee the truth of everything which is articulated as such. He is the truest of the true, the guarantor that the truth exists and all the more the guarantor in that this truth as such could be different, Descartes tells us, it could be if this God wanted it, it could be properly speaking error. What does that mean if not that we find ourselves there in everything that one can call the battery of the signifier confronted with this single trait, with this einzigiger Zug which we already know, so that if really necessary it could be substituted for all the elements of what constitutes the signifying chain, supports this chain, all (17) by itself and simply by being always the same.

What we find at the limit of the Cartesian experience as such of the vanishing subject, is the necessity of this guarantor, of the most simple structural trait, of the unique trait, absolutely depersonalised, may I say, not alone of all subjective content, but even of all variation which goes beyond this single trait, of this trait which is one by being the single trait.

The foundation of the one which this trait constitutes is grasped nowhere other than in its unicity: as such one can say nothing else about it except that it is what all signifiers have in common by being above all constituted as a trait, by having this trait as a support.

Are we going to be able, to encounter ourselves around this in our concrete experience? I mean that what you already see highlighted, namely the substitution which already gave so much trouble to philosophical thought, namely this almost necessarily idealistic slope that every articulation about the subject has in the classical tradition, of substituting for it this function of idealisation in so far as on it there reposes this structural necessity, which is the same as the one which I already articulated before you under the form of the ego-ideal, in so far as it is starting from this not at all mythical but perfectly concrete point of inaugural identification of the subject to the radical signifier, not at all of the Plotinian one, but of the single trait as such that the whole perspective of the subject as (18) not knowing can be unfolded in a rigorous fashion. It is this that after having made you pass today no doubt along paths, about which I wish to reassure you by telling you that it is certainly the most difficult peak of the difficulty to which I have to make you pass, which has been gone through today, it is this that I think I will be able before you, in a more satisfying fashion, more designed to help us rediscover our practical horizons, to begin to formulate.

Seminar 3: Wednesday 29 November 1961

I led you then the last time to this signifier that the subject must in some way be in order for it to be true that the subject is signifying (signifiant) .

It is a matter very precisely of the 1 qua single trait; we could be very subtle about the fact that the primary teacher writes the 1 like that with a rising stroke which indicates in a way where it emerges from. Moreover it would not be a pure refinement because after all it is precisely what we also are going to do: try to see where it comes from. But that is not where we are at. So, as a way of accommodating your mental vision which is very confused by the effects of a certain cultural fashion, very precisely the one which leaves a gaping interval between primary teaching and the other which is called secondary, you should know that I am not in the process of directing you towards the one of Parmenides, nor the one of Plotinus, nor the one of any totality in our field of work of which such a great fuss has been made for some time. It is indeed a question of the 1 which I called earlier that of the primary teacher, the one of "pupil X, write out a hundred lines of 1's for me", namely strokes: "pupil Y, you will get 1 in French". The teacher in his notebook, traces out the einziger Zug, the single trait of the sign which has always been sufficient for minimal notation. This is what is in question, the relationship of this with what we are dealing with in identification. If I establish a relationship, it should (2) perhaps begin to appear to your mind as a dawning, that identification is not immediately collapsed. It is not altogether simply this 1, in any case not as we envisage it: as we envisage it, it can only be - you see already the path that I am leading you along - at a pinch the instrument of this identification and you are going to see, if we look closely at it, that this is not so simple.

Because if what thinks, the thinking being we are considering, remains at the level of the real in its opacity, it does not immediately follow that he emerges from some being where he is not identified, I mean: not even from some being where it is in short thrown on the paving of some extension which first of all required thinking in order to clear it away and to make it void. Not even that: this is not where we are at. At the level of the real, what we can glimpse, is to glimpse him among so many beings also, in one word, so many beings of a etr'etant where he is hanging on to some breast, in short, at the very most capable of

outlining this sort of palpitation of being which makes laugh so much the enchanter at the bottom of the tomb where the cunning of the lady of the lake has imprisoned him.

Remember - it is a few years ago, the year of the seminar on President Schreber - the image that I evoked during the last seminar of the year, the poetic one of the monster Chapalu after he had satiated himself on the bodies of the sphinxes mutilated by their suicidal leap, this remark about which the rotting enchanter who is the monster Chapalu laughs for a long time "someone who eats is no longer alone".

(3) Of course, in order for being to come to birth, there is the perspective of the enchanter; it is indeed it which at bottom regulates everything. Of course, the veritable ambiguity of this coming to birth of the truth is what constitutes the horizon of our whole practice. But it is not at all possible for us to start from this perspective which the myth indicates well enough to be beyond the mortal limit: the enchanter rotting in his tomb. So is not this also a point of view which is always completely abstract when it is thought about, at an epoch when the ragged fingers of Daphne's tree, if they are profiled against the field charred by the giant mushroom of our omnipotence which is always present today at the horizon of our imagination, are there to recall for us the beyond from which there can be posed the point of view of the truth. But it is not contingency which brings it about that I have to speak here before you about the conditions of the truthful. It is a much tinier incident the one which summoned me to take care of you in so far as you are a handful of psychoanalysts and I remind you that you certainly do not have the truth in great quantities, but that all the same this is your stock and trade, this is what you sell.

It is clear that in coming to you people are chasing the truth, as I said the time before last it is the truth about the true that is being sought. It is precisely for this reason that it is legitimate that, to deal with identification, I should have started from a text whose rather unique character in the history of philosophy I tried to make you sense in that the question of the truth being posed in it in a specially radical fashion, in so far as it puts in question, not at all the truth that is found in the real, but (4) the status of the subject in so far as he is charged to bring this truth into the real, I found myself, at the end of my last discourse, the one I gave last time, ending up with what I indicated to you as recognizable in the figure already mapped out for us of the single trait of the einzigiger Zug in so far as it is on it that there is concentrated for us the function of indicating the place where there is suspended in the signifier, where there is hooked on, as regards the signifier, the question of its guarantee, of its function, of what use this is, this signifier in the advent of the truth. This is why I do not know how far I will be able to push my discourse today, but it will be entirely turning around the goal of ensuring in your minds this function of the single trait, this function of the one.

Of course, this is at the same time to put in question, this is at the same time to make advance - and I expect to encounter because of this fact in you a type of approbation, from the heart to the belly - our knowledge of what this signifier is.

I will begin, because that is what I feel like doing, by making you play truant. I made an allusion the other day to a kind remark, however ironical it may have been, concerning the choice of my subject for this year as if it were not at all absolutely necessary. This is an opportunity to focus on the fact, and this is surely connected in some way to the reproach, that it implied that identification is somehow or other a master key which would avoid having to refer oneself to an imaginary relationship which alone supports the experience of it, namely the relationship to the body.

(5) All of this is consistent with the same reproach which may be addressed to me about the paths that I pursue, of always keeping you too much at the level of the articulations of language the one which precisely I strive to distinguish from all others. From that to the idea that I overlook what is called the preverbal, that I overlook the animal, that I believe that man in all this has some privilege or other, there is only a step which is all the more quickly taken because one does not have any sense of taking it. It was in thinking again about it, at the moment when more than ever this year I am going to make everything that I am going to explain to you turn around the structure of language, that I went back to an experience of mine which is close, immediate, near at hand, tangible and appealing and which perhaps will clarify the fact that I also have my notion of the preverbal which is articulated within the relationship of the subject to the word in a fashion which has not been apparent perhaps to all of you.

Close by me, in the midst of the Mitseinden environment in which I live as Dasein, I have a dog whom I named Justine as a homage to Sade, without you can be sure my exercising any particular cruelty towards her. My dog, in my sense and without ambiguity, speaks. My dog has without any doubt the gift of speech. This is important, because it does not mean that she possesses language totally. The measure in which she has speech without having the human relationship to language is a question from which it is worthwhile envisaging the problem of the preverbal. What does my dog do when she speaks, in my sense? Why do I say that she speaks? She does not speak all the time, she speaks contrary to many humans only at moments when she needs to (6) speak. She has a need to speak at moments of emotional intensity and of relationships to the other, to myself, and some other people.

This manifests itself by sorts of little guttural whimpers. It is not limited to that. It is particularly striking and pathetic since it manifests itself in a quasi-human way which is what brought it about that I had today the idea of speaking to you about it: she is a boxer bitch, and you see there appearing on this quasi-human facies, rather Neanderthal when all is said and done, a certain trembling of the lip especially the upper one under this muffle, a little high for a human, but after

all there are types like that: I had a caretaker who looked terribly like her, and this trembling of the lip when the caretaker had to communicate with me at one or other high point of intentionality was not at all sensibly different. The effects of breathing on the animal's cheeks evoke no less sensibly a whole set of mechanisms of a properly phonatory type which, for example, would be completely suitable for the celebrated experiments of Abbe Rousselot, the founder of phonetics. You know that they are fundamental and consist essentially in filling the diverse cavities in which there are produced phonatory vibrations with little drums, horns, vibrating instruments which allow there to be controlled at what levels and at what moments there come to be superimposed the diverse elements which constitute the emission of a syllable, and more precisely everything that we call a phoneme, because these phonetic experiments are the natural antecedents of what was afterwards defined as phonematics.

My dog has speech, and it is uncontestable, indisputable, not only from the fact that the modulations which result from these (7) properly articulated decomposable efforts inscribable in loco, but also from the correlations between the moments at which these phonemes are produced, namely when she is in a room where experience has taught the animal that the human group gathered around a table should be there for a good while, that some spin-off from what is happening at that moment, namely the festivities, should accrue to her: it must not be believed that all of this is centred on need. There is no doubt a certain relationship with this element of consumption, but the communing element of the fact that she is eating with the others is present in it.

What is it that distinguishes this usage, which is in short very sufficiently successful as regards the results that it is a question of obtaining for my dog, of speech, from human speech? I am not in the process of giving you words which claim to cover all the results of the question, I am only giving responses which are orientated towards what should be for all of us what it is a question of mapping out, namely: the relationship to identification. What distinguishes this speaking animal from what happens because of the fact that man speaks is the following, which is quite striking as regards my dog, a dog who could well be yours, a dog who has nothing extraordinary about her, is that, contrary to what happens in the case of man in so far as he speaks, she never takes me for another. This is very clear: this shapely boxer bitch who, if one is to believe those who observe her has feelings of love for me, gives herself over to fits of passion towards me in which she takes on a quite terrifying aspect for the more timorous souls who exist for example at one or other level of my offspring: it appears that (8) people are afraid that, at the moments that she begins to jump on top of me with her ears flattened and growling in a certain fashion, the fact that she takes my wrists between her teeth might appear to be a threat. This is nevertheless not at all the case. Very quickly, and this is why it is said that she loves me, a few words from me bring her to order, even if I have

to repeat myself a few times, and stop the game. The fact is that she knows very well that it is I who am there, she never takes me for another, contrary to what in all your experience is there to testify about what happens in the measure that, in the analytic experience, you put yourself in the conditions of having a "pur-parlant" subject, if I may express myself in that way as one speaks about a pure pork pate. The purely-speaking subject as such, it is the very birth of our experience, is led, because he remains purely-speaking, to take you always for another. If there is some element of progress in the paths on which I am trying to lead you, it is to make you that by taking you for another, the subject puts you at the level of the Other with a big 0.

It is precisely this which is lacking to my dog: for her there is only the small other. As regards the big Other, it does not seem that her relationship to language gives her access to it. Why, since she speaks, does she not manage to constitute at all as we do these articulations in such a fashion that the locus of this Other where the signifying chain is situated is developed for her as for us?

Let us rid ourselves of the problem by saying that it is her sense of smell which prevents it for her, and here we are only (9) rediscovering a classical indication, namely that the organic regression of the sense of smell in the case of man has a lot to do with his access to this Other dimension.

I am very sorry to appear, with this reference, to be re-establishing the cut between the canine species and the human species. I am saying this to signify to you that you would be completely wrong to believe that the privilege I give to language is some sort of pride which hides this sort of prejudice which would make of man precisely some sort of summit of being. I would temper this cut by telling you that if my dog lacks this sort of possibility which was not separated out as autonomous before the existence of analysis which is called the capacity for transference, that does not at all mean that this reduces for her partner, I mean for myself, the emotionally expressive field of that which in the current sense of the term I call precisely human relations. It is manifest, in the behaviour of my dog, concerning precisely the reflux onto her own being of the effects of comfort, of positions of prestige, that a large part, let us say it, if not the totality of the register of what constitutes the pleasure of my own relationship, for example, with a woman of the world, is there completely fulfilled. I mean that, when she occupies a privileged place like the one which consists in climbing onto what I call my cot, in other words the marriage bed, the sort of look with which she fixes me on such occasions, suspended between the glory of occupying a place whose privileged signification she situates perfectly well and the fear of the imminent gesture which is going to dislodge her from it, is not at all of a different dimension to what can be seen in the look of what I called, in a purely demagogical way, a woman of the (10) world; because if she does not have, in what concerns what can be called the pleasure of conversation, a special privilege,

she has just the same look, when having taken off in a dithyramb about some film or other which appears to her to be the latest thing in technical achievement, she feels suspended over her a declaration from me that I was bored to the teeth with it, which from the point of view of nihil mirari, which is the law of good society, already gives rise in her to the suspicion that she would have done better to let me speak first.

This by tempering, or more exactly by re-establishing the sense of the question that I am posing concerning the relationships of speech to language, is designed to introduce what I am going to try to separate out for you concerning what specifies a language as such; the tongue as it is called, in so far as, if it is the privilege of man, it is not immediately completely clear why it should be limited to him. I assure you that it is worthwhile spelling this out. I spoke about a tongue: for example, it is not indifferent to note - at least for those who have not heard about Rousselot here for the first time, it is all the same very necessary that you should at least know how Rousselot's reflexes are constituted - I allow myself to see right away the importance of something, which was absent from my earlier explanation about my dog, that I am speaking about something pharyngeal, something glottal, and then about something which was trembling all around here and there and therefore which is recordable in terms of pressure, of tension. But I did not speak at all about the effects of the tongue: there is nothing here (11) which produces a click for example, and still less which produces an occlusion; there is undulation, sighing, breathing, there are all sorts of things which are close to it, but there is no occlusion.

I do not want to go on about this too much today, this is going to push into the background things about the l; too bad, one has to take the time to explain things. If I underline it in passing, you can be sure that it is not for the pleasure of it, it is because we will rediscover - and this we can only do retrospectively - its meaning. It is perhaps not an essential pillar of our explanation but this phase of occlusion will in any case take on its meaning at a particular moment; and the sketches of Rousselot, which perhaps you for your part will have consulted in the interval, since this will allow me to abbreviate my explanation, will perhaps be particularly expressive at that time.

In order to properly image for you for now what the solution is, I am going to give you an example of it; the phonetician encounters in the same step - and it is not without reason as you are going to see - the phoneme PA and the phoneme AP, which allows him to pose the principles of the opposition between the implosion AP and the explosion PA and to show us that the consonance of P is, as in the case of your daughter, to be mute. The meaning of P is between this implosion and this explosion. The P is heard precisely because it is not heard and this silent time in the middle, hold onto the formula, is something which, at the very phonetic level of the word, is what might be called a sort of announcement of a certain point to which, as you will see, I will lead you after some detours. I am

taking advantage simply of the passage through my dog, to indicate it to you in passing and to make you notice at the same (12) time that this absence of occlusives in the speech of my dog, is precisely what it has in common with a spoken activity which you know well and which is called singing.

If it often happens that you do not understand what the singer is saying, it is precisely because one cannot sing occlusives and I also hope that you will be happy to land on your feet again by thinking that everything is in order because in short my dog sings, which reinserts her into the concert of the animals. There are many others who sing and the question is not still demonstrated whether for all that they have a language.

People have always spoken about this, the Shaman whose representation I have on a very beautiful little grey bird fabricated by the Kwakiutl of British Columbia carries on his back a sort of human image who communicates in a tongue which links him with a frog: the frog is supposed to be communicating to him the language of animals. It is not worth the trouble to do all this ethnography because, as you know St. Francis spoke to the animals: he is not a mythical personage, he lived at a epoch incredibly illuminated already in his time by the full light of history. There are people who have made very pretty little paintings in order to show him to us on a rock, and one sees out at the very edge of the horizon the mouths of fish emerging from the sea in order to hear him which is the all the same, you have to admit, quite something.

One might in this connection ask oneself in what tongue he spoke to them. This always has a meaning at the level of modern (13) linguistics, and at the level of psychoanalytic experience. We have learned to define perfectly the function in certain beginnings of the tongue of what is called baby-talk, this thing which gets on the nerves of some people, me for example, this type of "gilly, gilly, what a lovely little baby". This has a role which goes well beyond these manifestations which are noted for their inane dimension, the inaneness consisting on this occasion in the feeling of superiority of the adult. There is nevertheless no essential distinction between what is called baby-talk and, for example, a sort of tongue like that which is called pidgin namely these sorts of tongues constituted when two types of language articulation enter into relationship, the users of one considering it to be both necessary and their right to use certain signifying elements which belong to the other region, and this with the aim of using them in order to make penetrate into the other region a certain number of communications which are proper to their own region, with this sort of prejudice which is in question in this operation of getting across to them, of transmitting to them categories of a higher order. These sorts of integration between one language region and another are one of the fields of study of linguistics, deserving then as such to be taken up as a quite objective value thanks to the fact that there exist precisely, with respect to language, two different worlds in that of the child and in that of the adult. We can all the less avoid taking it into account, we can all the less neglect it

in that it is in this reference that we find the origin of certain rather paradoxical traits of the constitution of signifying batteries, I mean the very particular prevalence of (14) certain phonemes in the designation of certain relationships which are called kinship, the not universal but overwhelming majority of phonemes PA and MA to designate, to furnish at least one of the modes of designation of the father and of the mother; this irruption of something which is only justified because of developmental elements in the acquisition of a language, namely pure speech events, this is only explicable precisely starting from the perspective of a relationship between two distinct spheres of language. And you see there being outlined here something which is again the outline of a frontier. I do not think that I am innovating here because you know what Ferenczi tried to begin to highlight under the title of "The confusion of tongues"¹¹ very specifically at this level of the verbal relationship between the child and the adult.

I know that this long detour will not allow me to tackle today the function of the One, it will perhaps allow me to add to it, because when all is said and done all that is in question here is to clear the way, namely that you should not believe that where I am leading you is a field which is exterior with regard to your experience, it is on the contrary the most internal field because this experience, the one for example which I evoked earlier specifically in the concrete distinction here between the other and the Other, all we can do is go through this experience. Identification, namely that which is able very precisely and also as intensely as possible, to imagine there being put under some sort of being of your relationships the substance of another, is something which can be illustrated to infinity in an "ethnographical" text because precisely (it is on this that there (15) has been constructed, with Levy-Bruhl, a whole series of theoretical conceptions which are expressed under the term: pre-logical mentality, indeed later on mystical participation, when he was led to focus more especially on the function of identification the interest of what seemed to him to be the path to the objectification of the field he had taken as his own. I think that here you know within what brackets, under what express reserve there can only be accepted relationships put under such a rubric. It is from something infinitely more common which has nothing to do with anything whatsoever which puts in question logic, or rationality, that one must start from in order to situate these facts (whether they are archaic or not) of identification as such. It is a fact which has always been known and can still be established for us when we address ourselves to subjects taken in certain contexts which remain to be defined, that these sorts of event - I am going to call them by terms which upset the barriers, which take things in a crude way in order to make it clearly understood that I do not intend here to stop at any dividing walls which are destined to obscure the primacy of certain phenomena - these phenomena of false recognition, let us say on the one hand of bi-location let us say of the other, flourish at the level of such experience, in the reports, in testimonies one hears. It is a matter of knowing why it is to the human being that these things happen; contrary

to my dog, the human being recognizes, in the emergence of such and such an animal the personage he has just lost, whether it is a question of his family or of an eminent personage of his tribe, the chief or someone else, the president of one or other society of young people or somebody else; he is this bison, that is him, or in a particular Celtic legend which by pure chance comes to me here because I would have to speak for all eternity to tell you (16) all things that arise in my memory in connection with this central experience... I take a Celtic legend which is not at all a legend, which is a piece of folklore taken from the testimony of someone who was a servant on a farm. On the death of the master of the place, of the lord, he sees appearing a little mouse, he follows it, the little mouse goes all around the field, she comes back, she goes into the shed where the agricultural implements are, she walks on these implements: on the plough, the hoe, the spade and the others, then she disappears. After that the servant, who already knew what was involved as regards the mouse, has a confirmation for it in the apparition of the ghost of his master who says to him, in effect: I was in that little mouse, I made a tour of the property to say goodbye to it, I had to see the agricultural implements because these are the essential objects to which one remains attached longer than to any other, and it is only after having made this tour that I could free myself from them etc... with an infinite number of considerations concerning in this regard a conception of the relationships of the dead person and certain instruments, linked to certain conditions of work, properly rural conditions, or more especially agrarian, agricultural conditions. I am taking this example to centre the gaze on an identification of being concerning two individual apparitions as obviously and as strongly to be distinguished from the one which would concern the being who, with respect to the narrating subject, had occupied the eminent position of master with this contingent little animal going one knows not where, going nowhere. There is something which, all by itself, deserves to be taken not simply to be (17) explained as a consequence, but as a possibility which deserves as such to be highlighted.

Does that mean that such a reference can engender anything other than the most complete opacity.

It would be a poor recognition of the type of elaboration, the order of effort that I am demanding from you in my teaching, to think that I could in any way content myself, even if one were to obliterate its limits, with a reference to folklore in order to consider as natural the phenomenon of identification: because once we have recognized this as the basis of the experience, we know absolutely no more about it, precisely in the measure that this can only happen to those I am speaking to in the most exceptional cases. It is always necessary to make a little reservation: you can be sure that this may perfectly well happen in one or other country area. That this cannot happen to you, you to whom I am speaking, is what settles the question: from the moment that this can no longer happen to you, you can understand nothing about it and, not being able to understand anything about it, do not believe that it is enough for you to connote the event

under some chapter heading, which you may call with M Levy-Bruhl mystical participation, or whether with the same man you make it enter under the great whole of the pre-logical mentality, for you to have said anything that is of the slightest interest.

It remains that what you can draw from it, make more familiar with the help of more attenuated phenomena, will not be for all that any more valuable because you will have started from an opaque foundation. You discover again here a reference of (18) Apollinaire: "Mange tes pieds a la Sainte Menehould", says the hero of the heroine of Mamelles de Tiresias somewhere to her husband. It is a matter for us of grasping the relationship between this possibility which is called identification, in the sense that from it there arises something that exists only in language, and thanks to language, a truth to which this is an identification which is not at all distinguished for the farm labourer who comes to tell you the experience that I spoke to you about earlier; and for us who found the truth on A is A: this is the same thing because what will be the starting point of my discourse the next time, will be this: why is it that A is A is an absurdity?

The strict analysis of the function of the signifier, in so far as it is through it that I intend to introduce for you the question of signification, starts with this: it is that if A is A, has constituted, as I might say, the condition of a whole era of thought of which the Cartesian exploration with which I began is the term - what one could call the theological era - it is no less true that linguistic analysis is correlative to the advent of another era, marked by precise technical correlations among which is the mathematical advent, I mean the extended use of the signifier in mathematics. We can glimpse that if the A is A does not work, I would take further the problem of identification. I indicate to you here and now that I will make my demonstration turn around the function of the one; and in order not to leave you completely in suspense and in order that perhaps each one of you would envisage beginning to formulate something on the path of what I will say to you about it, I would (19) ask you to refer to the chapter in de Saussure's Course in linguistics which ends on page 175. This chapter ends with a paragraph which begins on page 174 and I will read the following paragraph of it:

"Applied to units, the principle of differentiation can be stated in this way: the characteristics of the unit blend with the unit itself. In a tongue, as in any semiological system," this would deserve a discussion, "whatever distinguishes one sign from the others constitutes it. Difference makes character just as it makes value and the unit". [English translation, page 121].

In other words, unlike the sign - and you will see it confirmed provided you read this chapter - what distinguishes the signifier, is simply being what the others are not; that which, in the signifier, implies this function of the unit, is precisely to be simply difference. It is qua pure difference that the unit, in its signifying function, structures itself, constitutes

itself. This is not a single trait. In a way, it constitutes a unilateral abstraction concerning the synchronic relationship for example of the signifier. As you will see the next time, nothing is properly speaking thinkable, nothing in the function is properly speaking thinkable, unless it starts from the following which I formulate as: the one as such is the Other. It is starting from here, from this fundamental structure of the one as difference that we can see appearing this origin from which one can see the signifier constituting itself, as I might say: it is in the Other (l'Autre) that the A of "A is A", the big O, as one says the great word, is released.

(20) From the processes of this language of the signifier, from here alone can there begin an exploration which is fundamental and radical of how identification is constituted. Identification has nothing to do with unification. It is only by distinguishing it from it that one can give it, not only its essential accent, but its functions and its varieties.

Seminar 4: Wednesday 6 December 1961

Let us take up again our idea, namely what I announced to you the last time that I intended to make pivot around the notion of the 1 our problem, that of identification, it being already announced that identification is not just simply to make 1, I think that this will not be difficult to admit.

We are starting, as is normal concerning identification, from the most common mode of access of subjective experience: that expressed by what appears to be the essentially communicable experience, in the formula which, at first sight, does not appear to give rise to objections that A is A. I said: at first sight because it is clear that, whatever may be the degree of belief involved in this formula, I am not the first to raise objections to it; you have only to open the smallest treatise on logic in order to encounter what difficulties the distinguo of this formula, in appearance the most simple, gives rise to of itself. You could even see that the greater part of the difficulties which are to be resolved in many domains - but it is particularly striking that it should be in logic more than elsewhere - come out of all the possible confusions which may arise from this formula which lends itself in an eminent way to confusion. If you have, for example, some difficulties, even some fatigue, in (2) reading a text as exciting as Plato's Parmenides, it is in as much as on this point of "A is A" let us say that you lack a little reflection, and in as much precisely that if I said above that the "A is A" is a belief, you must indeed understand it in the way I told you: it is a belief which has certainly not always reigned over our species, in as much as after all, the A indeed began somewhere - I am speaking about A, the letter A - and that it must not have been so easy to gain access to this kernel of apparent certainty that there is in "A is A", when man did not the A at his disposition.

I will tell you a little later the path onto which this reflection may lead us; it would be well all the same to be aware of the new thing that arrives with the A; for the moment let us content ourselves with something that our language here allows us to articulate well: it is that "A is A" appears to mean something: it makes a "signified" (cela fait "signifie").

I pose, very sure that I will not encounter on this point any opposition from anybody, and on this theme in a position of competence which I put to the test through the testimonies of what can be read about the matter, as well as by challenging one

or other mathematician who is sufficiently familiar with his science to know where we are at at the present time for example, and then many others in all sorts of domains, that I will encounter no opposition in putting forward under certain conditions of explanation which are precisely those to which I am going to submit myself before you, that "A is A" signifies nothing. It is precisely this nothing (rien) that is going to be in question, because this nothing has a positive value because it says what that signifies. We have in our experience, indeed in our (3) analytic folklore, something, the image never sufficiently explored, exploited, which is the game of the little child so shrewdly picked out by Freud, perceived in such a perspicacious fashion in the Fort-Da. Let us take it up on our own account since, from an object taken up and rejected - the child in question is his grandson - Freud was able to glimpse the inaugural gesture in the game. Let us remake this gesture, let us take this little object: a ping-pong ball, I take it, I hide it, I show it to him again; the ping-pong ball is the ping-pong ball, but it is not a signifier, it is an object, it is an approach to say: this little o is a little o; there is between these two moments, which I indisputably identify in a legitimate fashion, the disappearance of the ball; without that there is no means for me to show it, there is nothing formed on the plane of the image. Therefore, the ball is always there and I can fall into a cataleptic state looking at it.

What relationship is there between the "is" which unites the two apparitions of the ball and this intervening disappearance?

On the imaginary plane, you sense that at least the question is posed of the relationship of this "is" with what seems indeed to cause it, namely the disappearance, and there you are close to one of the secrets of the identification which is the one to which I tried to get you to refer in the folklore of identification: this spontaneous assumption by the subject of the identity of two appearances which are nevertheless quite different. Remember the story of the dead farm owner whom his servant rediscovers in the body of the mouse. The relationship (4) of this "it is him" with the "it is him again", this is what for us gives its model and its register to the most simple experience of identification. Him, then him again, there is here the being-perspective of the question; in "him again", it is the same being who appears. As regards the other, in short, it is all right like that, it is satisfactory; for my dog whom I took the other day as a term of reference, as I told you, it is all right; this reference to being, is sufficiently, it seems, supported by her sense of smell; in the imaginary field the support of being is easily conceivable: it is a matter of knowing if it is effectively this simple relationship that we are dealing with in our experience of identification. When we speak about our experience of being, it is not at all for nothing that a whole effort of a thought which is our own contemporary one, is going to formulate something whose centrepiece I never shift without a certain smile, this Dasein, this fundamental mode of our experience in which there must be designated the centrepiece giving every access to this term of being, as a primary

reference.

It is here indeed that something else forces us to question ourselves about the fact that the punctuation in which this presence to the world manifests itself is not simply imaginary, namely that already it is not at all to the other that we refer ourselves here, but to this most intimate part of ourselves which we try to make the anchoring point, the root, the foundation of what we are as subjects. For, if we can articulate, as we have done, on the imaginary plane, that my dog recognises me as the same, we have not on the contrary any indication about the fashion in which she identifies herself; in whatever way we may (5) re-engage her within herself, we know nothing at all, we have no proof, no testimony about the mode under which she approaches this identification. It is indeed here that there appears the function, the value of the signifier same (meW) as such; and it is in the very measure that we are dealing with the subject that we have to question ourselves about the relationship of this identification of the subject with what is a different dimension to everything that is the order of appearance and disappearance; namely the status of the signifier. That our experience shows us that the different modes, the different angles under which we are led to identify ourselves as subjects, at least for some of us, supposes the signifier to articulate it, even most often under an ambiguous, improper, difficult-to-handle form subject to all sorts of reservations and of distinctions which the "A is A" is, this is what I want to draw your attention to and first of all without dallying any longer show you that if we have the good fortune to take a further step in this direction, it is by trying to articulate this status of the signifier as such. I am indicating it right away: the signifier is not at all the sign. It is with giving to this distinction its precise formula that we are going to busy ourselves; I mean that it is to show where this difference lies that we can see arising from the fact already given by our experience that it is from the effect of the signifier that the subject as such emerges. Metonymical effect, metaphorical effect, we do not yet know and perhaps there is something already articulatable before these effects which allows us to see dawning, being formed in a relationship, in a link, the dependence of the subject as such with respect to the signifier. (6) This is what we are going to see by putting it to the test. To anticipate what I am trying here to make you grasp, to anticipate it in a short image to which it is only a matter of giving again a sort of value as a support, as a apologue, you should measure the difference between the following which is going at first perhaps to appear to you as a play on words - but precisely it is one - there is the footprint (la trace d'un pas). Already I led you along this trail, strongly tainted with myth, precisely correlative to the time where there begins to be articulated in thinking the function of the subject as such: Robinson Crusoe in front of the footprint which shows him that on the island he is not alone. The distance which separates this pas from what the pas as instrument of negation has become phonetically, these are two extremes of the chain that here I ask you to hold onto before showing you effectively what constitutes it and that it is between the two extremities of the chain that

the subject can emerge and nowhere else.

By grasping it, we will manage to relativise something in such a way that you can consider this formula "A is A" itself as a sort of stigma, I mean in its character of belief as the affirmation of what I would call an epoch: epoch, moment, parenthesis, historical term after all whose field we can glimpse - as you will see - as limited.

What I called the other day an indication, which will remain still only an indication of the identity of this false coherence of the "A is A" with what I called a theological era, will allow me, I believe, to take a step in what is at stake concerning the problem of identification, in so far as analysis requires that it (7) should be posed, with respect to a certain accession to the identical, as the transcendent A [¹Autre?].

This fecundity, this sort of determination which is suspended from this signified of "A is A" could not repose on its truth, because this affirmation is not true. What it is a question of reaching in what I am striving to formulate before you, is that this fecundity reposes precisely on the objective fact - I employ objective there in the sense that it has for example in Descartes' text: "when one goes a little further, one sees the distinction arising as regards the ideas between their actual reality and their objective reality", and naturally professors produce very learned volumes for us such as a Scholastico-Cartesian index in order to tell us something that seems here for the rest of us, since God knows we are very smart, a little confused, that this is a legacy of Scholasticism by means of which it is believed that everything is explained. I mean that one has spared oneself what is really involved, namely: why Descartes the anti-Scholastic, was led for his part to make use again of these old props. It seems that it does not come so easily to the mind of even the better historians that the only interesting thing is what made it necessary for him to wheel them out again. It is quite clear that it is not in order to remake anew the argument of St Anselm that he drags all of this out again into the forefront of the stage. The objective fact that "A" cannot be "A", this is what I would first of all like to highlight for you; precisely in order to make you understand that it is with something which has a relationship with this objective fact that we are dealing and this up to the false signified- (8) effect which is only a shadow here and, as a consequence, which leaves us attached to this spontaneity that there is in the "A is A".

That the signifier has a fecundity because it is never in any case identical to itself, understand clearly here what I mean: it is quite clear that I am not in the process, even though it would be worth the trouble in passing to distinguish it from it, of pointing out to you that there is no tautology in the fact of saying that "war is war". Everyone knows that: when one says "war is war", one is saying something, one does not know exactly what moreover, but one can seek it, one can find it and one finds it very easily within hand's reach; that means: that which begins

at a certain moment: we are in a state of war. This involves conditions of things which are a little bit different, this is what Peguy called that "the little pegs no longer fitted into the little holes". It is a Peguy-type definition, namely that it is not at all certain: one could even sustain the contrary, namely that it is precisely in order to put the little pegs back in their real little holes that war begins, or on the contrary it is to make new little holes for the old little pegs, and so on. Moreover this has strictly no interest for us, except that this pursuit whatever it may be is accomplished with a remarkable efficacy by means of the most profound imbecility, something which ought equally make us reflect on the function of the subject with respect to the effects of the signifier.

(9) But let us take something simple, and let us finish with it quickly. If I say "my grandfather is my grandfather" you should all the same fully grasp here that there is no tautology: that my grandfather, the first term is an index usage of the term "my grandfather", which is not tangibly different from his proper name, for example Emile Lacan, nor of the "C" either of the "C'est" when I point him out when he enters a room: "C'est mon grand'pere". This does not mean that his proper name is the same thing as this "C"¹, of this is my grandfather. One is stupefied that a logician like Russell was able to say that the proper name belongs to the same category, to the same signifying class as the this, that or it, under the pretext that they are susceptible to the same functional usage in certain cases. This is a parenthesis, but like all my parentheses, a parenthesis designed to be rediscovered further on in connection with the status of the proper name of which we will not speak today.

In any case, what is in question in "my grandfather is my grandfather" means that the execrable petit bourgeois that this gentleman was, this horrible personage thanks to whom I acceded at an early age to this function of cursing God, this personage is exactly the same as the one who is posted on the civil register as being demonstrated by the bonds of marriage to be the father of my father, in as much as it is precisely the birth of the latter that is at stake in the act in question. You see therefore the degree to which "my grandfather is my grandfather" is not at all a tautology. This applies to all tautologies and this does not at all give their univocal formula, because here it is a question of a relationship of the real to the symbolic; in (10) other cases there will be a relationship of the imaginary to the symbolic, and you would have to go through the whole sequence of permutations in order to see which are valid. I cannot engage myself along this path because if I talk to you about this which is in a way a method of excluding false tautologies which are simply the permanent current usage of the language, it is in order to tell you that this is not what I mean. If I pose that there is no tautology possible, it is not in so far as the first A and the second A mean different things that I say that there is no tautology, it is in the very status of A that there is inscribed that A cannot be A, and it was on this that I ended my discourse the last time by designating for you in Saussure the point where it is said that A as signifier cannot in any way be

defined except by not being what the other signifiers are.

From this fact, that it cannot be defined except precisely by not being all the other signifiers, on this there depends this dimension that it is equally true that it cannot be itself. It is not enough to put it forward in this way in this opaque fashion precisely because it surprises, it upsets, this belief suspended on the fact that this is the real support of identity: you must be got to sense it.

What then is a signifier?

If everybody, and not alone the logicians speak about A when it is a question of "A is A", it is not after all by chance. It is because in order to support what one desires, a letter is necessary. You will grant me this, I think, but moreover I do (11) not hold this leap to be decisive except for the fact that my discourse cross-checks with it, demonstrates it in a sufficiently superabundant fashion for you to be convinced of it; and you will be all the more convinced because I am going to try to show you in the letter precisely this essence of the signifier through which it is distinguished from the sign.

I did something for you last Saturday in my house in the country where I have hanging on the wall what is called a Chinese calligraph. If it were not Chinese, I would not have hung it on my wall for the reason that it is only in China that the calligraph has taken on a value as an object d'art: it is the same thing as having a painting, it has the same price. There are the same differences and perhaps even more between one writing and another in our culture as in Chinese culture, but we do not attach the same price to it. On the other hand, I will have occasion to show you what can mask from us the value of the letter which, because of the particular status of the Chinese character, is particularly well highlighted in this character. What I am going to show you only takes on its full and most exact position from a certain reflection about what the Chinese character is: I already all the same made allusion enough on occasions to the Chinese character and to its status for you to know that to call it ideographic is not at all sufficient. I will show it to you perhaps in greater detail, this moreover is what it has in common with everything that is called ideographic, there is properly speaking nothing which merits this term in the sense in which one imagines it habitually, I would say almost specifically in the sense that de Saussure's little schema, with arbor and the tree drawn underneath, still sustains it through a (12) kind of imprudence which is what misunderstandings and confusions attach themselves to.

What I want to show you here, I made two examples of. I was brought at the same time a new little instrument that certain painters make a lot of, which is a sort of thick brush where the ink comes from inside which allows the traits to be traced out with a worthwhile thickness and consistency. The result is that I copied much more easily than I would normally have done the form that the characters on my calligraph have: in the left hand

column here is the calligraphy of this sentence which means "the shadow of my hat dances and trembles on the flowers of Hai Tang"; on the other side, you see the same sentence written in the usual characters, those which are the most legitimate, those that the stumbling student makes when he makes his characters correctly: these two series are perfectly identifiable and at the same time they do not resemble one another at all. Notice that it is in the clearest fashion in so far as they do not resemble one another at all that there are quite obviously from top to bottom on the right and on the left, the same seven characters, even for someone who has no idea not alone about Chinese characters, but no idea up to now that there were things which were called Chinese characters. If someone discovers that for the first time drawn somewhere in a desert, he will see that on the right and on the left it is the same characters that are in question and the same series of characters on the right and on the left.

(13) This to introduce you to what constitutes the essence of the signifier and which it is not for nothing that I will illustrate best in its simplest form which is what we have been designating for some time as the einziger Zug. The einziger Zug which is what gives to this function its value, its act and its mainspring, this is what makes it necessary, in order to dissipate the confusion that may remain here, for me to introduce in order to express it in the best and closest possible way this term which is not at all an neologism, which is used in what is called set theory: the word unary (unaire) instead of the word single (unique). At the very least it is useful for me to make use of it today in order to make you properly sense this core that is in question in the distinction of the status of the signifier. This unary trait, therefore, whether it is vertical like here - we call that drawing strokes - or whether it is, as the Chinese do it, horizontal, it might seem that its exemplary function is linked to the extreme reduction, precisely with regard to it, of all the opportunités for qualitative difference. I mean that from the moment when I must simply make a trait, there are not, it seems, many varieties nor many variations. This is what gives it its privileged value for us, disabuse yourselves: just as it was not a matter earlier in order to discover what was in question in the formula: "there is no tautology" of pursuing tautology there precisely where it did not exist, so now it is not a matter here of discerning what I called the perfectly graspable character of the status of the signifier whatever it may be, A or another one, in the fact that something in its structure might eliminate these differences. I call them qualitative because it is this term that the logicians use when (14) it is a question of defining identity by the elimination of qualitative differences by reducing them as one might say to a simplified schema: this is supposed to be the mainspring of this recognition characteristic of our apprehension of what is the support of the signifier, the letter.

That is not it at all, this is not what is in question. Because if I make a line of strokes, it is quite clear that, however well I may apply myself, there will not be a single one like any another and I would say more: they are all the more convincing as

a line of strokes in that precisely I have not applied myself so much to make them rigorously alike.

Since I have been trying to formulate for you what I am in the process of formulating at the moment, I have questioned myself with the means at my disposal, namely those which are given to everyone, about something which after all is not immediately obvious: at what moment does one see appearing a line of strokes? I was in a really extraordinary place whose emptiness perhaps after all through my remarks I am going to draw people to animate, I mean that some of you are going to rush over there, I mean the museum of Saint-Germain. It is fascinating, it is exciting and it will be all the more so if you try all the same to find someone who was already there before you because there is no catalogue, no plan and it is completely impossible to know where and who and what, and to find out where one is in this series of rooms. There is a room which is called La Salle Piette, from the name of the justice of the peace who was a (15) genius and who made the most fantastic discoveries about pre-history, I mean from some tiny objects, in general of a very small size, which are the most fascinating things that you could see. And to hold in one's hand the little head of a woman which is certainly about 30,000 years old has all the same its value, besides the fact that this head is full of questions. But you can see in a glass case - it is very easy to see, because thanks to the testamentary dispositions of this remarkable man they are absolutely obliged to leave everything in the greatest possible disorder with completely out-of-date showcards on the objects, they have succeeded all the same in putting on a piece of plastic something which allows to be distinguished the value of certain of these objects. How can I tell you the emotion that I felt when bending over one of these glass cases I saw on a thin rib-bone, obviously the rib of a mammal - I do not really know which one, and I do not know whether anyone would know better than I, a type of Cervide deer - a series of little strokes: first two, then a little interval and afterwards five, and then it recommences. There, I said to myself addressing myself by my secret or my public name, this is why in short Jacques Lacan your daughter is not mute, this is why your daughter is your daughter, because if we were mute she would not be your daughter. Obviously, there is some advantage in this, even living in a world very like that of a universal asylum of madmen, a no less certain consequence of the existence of signifiers, as you are going to see.

These strokes which only appear much later, several thousand (16) years after men knew how to make objects of a realistic exactitude, when at the Aurignacian epoch bisons were made which are beyond anything from the point of view of the art of the painter that we have yet been able to achieve! But what is more, at the same epoch people made in bone on a very small scale, a reproduction of something that it might not seem one should have taken so much trouble over because it is a reproduction of something else in bone but which is much bigger: a horse's skull. Why redo in bone on a small scale, when really one imagines that at that epoch they had other things to be doing, this matchless

reproduction? I mean that, in le Cuvier which I have at my country house, I have extremely remarkable engravings of fossilized skeletons which are made by consummate artists, these are no better than this small reduction of a horse's skull sculptured in bone which is of such an anatomical exactitude that not only is it convincing: it is rigorous.

Well then it is only much later that we find the trace of something which belongs unambiguously to the signifier.

And this signifier is all alone, because I do not intend giving, for want of information, a special meaning to this little increased gap that there is some place in this line of strokes; it is possible, but I can say nothing about it. What I mean, on the contrary, is that here we see arising something which I am not saying is the first appearance, but in any case a certain (17) appearance of something which you see is altogether distinguished from what can be designated as a qualitative difference: each one of these traits is not at all identical to its neighbour, but it is not because they are different that they function as different, but because the signifying difference is distinct from anything that refers to qualitative difference, as I have just shown you with the little things that I have just circulated before you.

Qualitative difference can even on occasion underline the signifying sameness. This sameness is constituted precisely by the fact that the signifier as such serves to connote difference in the pure state, and the proof is that at its first appearance the one manifestly designates multiplicity as such. In other words, I am a hunter because now we have been carried to the level of Magdalenian 4. God knows that catching an animal was not any more simple at that epoch than it is in our own day for those who are called Bushmen, and it was quite an adventure! It seems indeed that after having wounded the beast it was necessary to track it for a long time in order to see it succumb to what was the effect of the poison. I kill one of them, it is an adventure, I kill another of them, it is a second adventure which I can distinguish by certain traits from the first, but which resembles it essentially by being marked with the same general line. At the fourth, there may be some confusion: what distinguishes it from the second, for example. At the twentieth, how will I know where I am, or will I even know that I have had twenty of them?

(18) The Marquis de Sade at the Rue Paradis in Marseille, locked up with his little valet, proceeded in the same way for the ejaculations (coups), even though varied in different ways, that he got off in the company of this partner, even with some confederates who themselves were varied in different ways. This exemplary man, whose relationships to desire must surely have been marked by some unusual ardour, whatever one might think, marked on the head of his bed, it is said, by little traits each one of the ejaculations - to give them their name - that he managed to achieve in this sort of singular probationary retreat. Undoubtedly one must oneself be well engaged in the adventure of

desire, at least according to everything that ordinary things teach us about the most ordinary experience of people, in order to have such a need to locate oneself in the sequence of one's sexual accomplishments: it is nevertheless not unthinkable that at certain favourable epochs of life something can become hazy about the exact point that one is at in terms of decimal enumeration.

What is in question in the notch, in the notched trait, is something of which we cannot help seeing that here there arises something new with respect to what one could call the immanence of any essential action whatsoever. This being whom we can imagine to be still lacking this method of location, what will he do, after a time which is rather short and limited by intuition, in order not to sense himself simply solidary with a present which is always easily renewable where nothing allows him any longer to discern what exists as difference in the real. It is not at all sufficient to say - this is already quite obvious - (19) that this difference is in the living experience of the subject just as it is not at all sufficient to say: "But all the same such and such a person is not me". It is not simply because Laplanche has hair like that and that I have hair like this and that his eyes are a certain way and that he has not got quite the same smile as me, that he is different.

You will say: "Laplanche is Laplanche and Lacan is Lacan". But it is precisely there that the whole question lies, since precisely in analysis the question is posed whether Laplanche is not the thought of Lacan and if Lacan is not the being of Laplanche or inversely. The question is not sufficiently resolved in the real. It is the signifier which settles it, it is it that introduces difference as such into the real, and precisely in the measure in that what is involved are not at all qualitative differences.

But then if the signifier, in its function of difference, is something which presents itself thus in the mode of the paradox of being precisely different because of this difference which would be based or not on similarity, of being something other which is distinct and as regards which - I repeat - we can very well suppose, because we have them within our reach, that there are beings who are alive and tolerate Very well completely ignoring this sort of difference which certainly, for example, is not at all accessible to my dog, and I will not show you immediately - because I will show it to you in greater detail and in a more articulated fashion - that it is indeed for that reason that apparently the only thing that she does not know, is that she herself is. And that she herself is, we ought to search for the mode under which this is appended to this sort of distinction which is particularly manifest in the unary trait in so far as (20) what distinguishes it is not at all an identity of resemblance, it is something else.

What is this other thing?

It is this: it is that the signifier is not at all a sign. A

is what ought to give us the effect that:

$$f \quad S \quad S' \quad S^{1'} \quad S^{1''} \quad \text{etc}$$

$$f (S, S', S^{1'} \dots) = S(-) s$$

I called that of the peu-de-sens, in so far as the minus sign designates, connotes a certain mode of appearance of the signified as it results from the putting into function of S the signifier in a signifying chain. $S(-) s$

We will put it to the test of a substitution for these S and S* of 1 in so far as precisely this operation is quite legitimate, and you know it better than anybody, you for whom repetition is the basis of your experience: what constitutes the core of repetition, of the automatism of repetition for your experience is not that it is always the same thing which is interesting, it is why there is repeated something of which precisely the subject from the point of view of his biological comfort has not - as you know - really any strict need as regards the repetitions that we have to deal with, namely the stickiest, the most annoying, the most symptomogenic repetitions. This is where your (23) attention should be directed in order to uncover in it as such the incidence of the function of the signifier.

How can it happen, this typical relationship to the subject constituted by the existence of the signifier as such, the only possible support of what is for us originally the experience of repetition?

Will I stop there or will I already indicate to you how the formula of the sign must be modified in order to grasp, to understand what is in question in the advent of the signifier. The signifier, as opposed to the sign, is not what represents something for someone, it is what represents precisely the subject for another signifier; my dog is on the lookout for signs and then she speaks, in the way you know, why is her speech not a language; because precisely I am for her something which can give her signs, but who cannot give her any signifier.

The distinction between speech (la parole), as it can exist at the preverbal level and language consists precisely in this emergence of the function of the signifier.

Seminar 5: Wednesday 13 December 1961

Monas esti kathen hekaston ton outon
 Arithmos de to ek monadon synkeimenon plethos
 Euclid - Elements 4 VII.

This sentence is a sentence borrowed from the beginning of the seventh book of Euclid's Elements and appeared to me, taking everything into consideration, the best one I found to express, on the mathematical plane, this function to which I wished to draw your attention the last time, of the 1 in our problem. It is not that I had to search for it, that I had trouble finding among the mathematicians something which referred to it: the mathematicians, at least some of them, those who at every epoch have been in the forefront of the exploitation of their field, have concerned themselves a lot with the status of the unit (1'unite), but they are far from all having arrived at equally satisfying formulae; it even seems that, for some of them, in their definitions it went right in the opposite direction to the appropriate one.

In any case, I am not unhappy to think that someone like Euclid who all the same in the matter of mathematics cannot be considered otherwise than as from the right stock, should give this formula, which is precisely all the more remarkable because it is articulated by a geometer, that what the unit is - because (2) this is the meaning of the word monas: it is the unit in the precise sense in which I tried to designate it for you the last time under the designation of what I called, I will come back again on the reason why I called it that: the unary trait; the unary trait in so far as it is the support as such of difference, this indeed is the meaning that monas has here. It cannot have a different one, as the rest of the text is going to show you.

Monas, namely this unit in the sense of the unary trait which I indicate here to you as cross-checking with, as highlighting in its function what we managed last year in the field of our experience to locate in the very text of Freud as the einzigere Zug, that through which every being is said to be a One, with the ambiguity that is brought by this en, the neuter of eis which means One in Greek, being precisely what can be employed in Greek as in French to designate the function of unity in so far as it is this factor of consistency through which something is distinguished from what surrounds it, makes a whole, a One in the unitary sense of the function; therefore it is through the

mediation of unity that each one of these beings comes to be called One. The advent, in the statement, of this unity as characteristic of each of the beings is here designated: it comes from the usage of the monas which is nothing other than the unary trait.

It was worthwhile picking up this thing precisely from the pen of a geometer namely of someone who situates himself in mathematics in such a fashion apparently that for him at least, we must say that intuition conserves all its original value. It is true that he is not just any old geometer, because in short we can (3) single him out in the history of geometry as the one who was the first to introduce, as having absolutely to dominate it, the exigency for proof over what could be called experience, the familiarity with space.

I will finish the translation of the quotation: "that number for its part is nothing other than this sort of multiplicity which arises precisely from the introduction of units", monads in the sense that this is understood in Euclid's text.

If I identify this function of the unary trait, if I make of it the unveiled face of this einzigiger Zug of identification, to which we were led by our path last year, let us highlight here, before going any further and so that you may know that contact is never lost with what is the most direct field of our technical and theoretical reference to Freud, let us highlight that it is a question here of the second kind of identification, p.117, volume 13 of the Gesammelte Werke of Freud. It is indeed as a conclusion to the definition of the second kind of identification which he calls regressive, in so far as it linked to a certain abandoning of the object that he defines as the beloved object. This beloved object goes from women to rare books.

It is always in some measure linked to the abandoning or the loss of this object that there is produced, Freud tells us, this sort of regressive state from which there arises this identification which he underlines (with something which is for us a source of admiration, as each time the discoverer designates a trait derived from his experience which it might seem at first approach is not required by anything, that it has a contingent character, (4) moreover he does not justify it, except by his experience) that in this sort of identification where the ego sometimes copies the situation of the unloved object, sometimes that of the beloved object, but that in both cases this identification is partial: "höchst beschränkt" extremely limited - but which is accentuated in the sense of narrowness, of restrictedness by the fact that it is "nur ein einziger Zug", only a single trait of the objectified person, which is like the place borrowed from the German word.

It may therefore seem to you that to approach identification through this second type, is also to "beschränken" myself, limit myself, restrict the import of my approach; because there is the other, the identification of the first kind, the singularly ambivalent one which is constructed on the basis of the image of

assimilating devouring; and what relationship has it with the third, the one which begins immediately after this point which I am designating for you in Freud's paragraph: the identification to the other through the instrumentality of desire, the identification that we know well, which is hysterical, but precisely which I taught you cannot be properly distinguished - I think you ought to be sufficiently aware of it - except when there has been structured - and I do not see anyone who has done it anywhere other than here and before it was done here - desire as presupposing in its underlay exactly as a minimum the whole articulation that we have given of the relationships of the subject specifically to the signifying chain, in so far as this relationship profoundly modifies the structure of every relationship of the subject with each one of his needs.

(5) This partiality of the approach, this way in, as I might say, into a corner of the problem, I have the feeling that at the same time as I designate it for you, I should legitimate it today, and I hope to do it quickly enough to allow myself to be understood without too many detours by recalling to you something that is a methodological principle for us: that, given our place, our function, what we have to do as we break new ground, we should be mistrustful, let us say - and take this as far as you wish - of genus and even of class.

It may appear strange to you that someone who accentuates for you the pregnancy, in our articulation of the phenomena with which we have to deal, of the function of language, marks himself off here from a mode of relationship which is really fundamental in the field of logic. How can one indicate, speak, about a logic which ought, at the very moment it begins, to mark the completely original distrust that I intend to pose about the notion of class? It is indeed precisely what makes original, distinguishes the field that we are trying to articulate here, it is not any prejudice in principle which leads me here; it is the very necessity of our own object which pushes us so that there is developed in the course of the years, segment by segment, a logical articulation which does more than suggest, which gets closer and closer, specifically this year, I hope, to disengaging the algorithms which allow me to describe as logical this chapter which we will have to add on to the functions exercised by language in a certain field of the real, the one of which we, as speaking beings, are the conductors.

(6) Let us distrust therefore in the most extreme way any "Koinonia" to use a Platonic term, everything that marks a community in any genus (genre) and especially in those which are most original for us. The three identifications probably do not form a class, even though they may nevertheless bear the same name which brings a shadow of the concept to it; it will be also no doubt up to us to account for it; if we work correctly, this does not seem to be beyond our strength. In fact, we know already that it is at the level of the particular that there always arises what is for us a universal function, and we have no reason to be too astonished by this in the field in which we move about because, as regards the function of identification, we know

already - we have worked enough together to know it - the meaning of this formula: what happens, happens essentially at the level of structure; and structure, do I need to remind you, and precisely I believe that today, before taking another step I must recall it - is what we have introduced specifically as a specification in the register of the symbolic. If we distinguish this register of the symbolic from the imaginary and the real - I believe I should also highlight all the hesitations that there may have arisen from this neglect of something that I have never seen anyone worry himself about openly, another reason for dissipating any ambiguity on it - it is not a matter of an ontological definition, it is not fields of being that I am separating out here. If from a certain moment on, and precisely that of the birth of these seminars, I believed I had to bring into play this triad of the symbolic, the imaginary and the real (7) it is in so far as this third element which was not at all up to then sufficiently discerned as such in our experience, is exactly to my eyes what is exactly constituted by this fact of the revelation of a field of experience. And, to remove any ambiguity from this term, it is a matter of the Freudian experience, I would say of a field of experimentation. I mean that we are not dealing with Erlebnis, we are dealing with a field constituted in a certain fashion up to a certain degree by some artifice, the one inaugurated by the analytic technique as such, the complementary aspect of the Freudian discovery, complementary as the front is to the back, really stuck together.

What is first of all revealed in this field, as you of course know is the function of the symbol and at the same time of the symbolic. From the beginning these terms had the fascinating, seductive, captivating effect which you know about, in the whole field of culture, this shock effect from which as you know scarcely any thinker, and even the most hostile, could stand aside from. It must also be said that it is a fact of experience that we have lost from this time of revelation, and of its correlation with the function of the symbol, we have lost its freshness, as one might say, this freshness which is correlative to what I called the effect of shock, of surprise, properly defined by Freud himself as characteristic of this emergence of the relationships of the unconscious, these sorts of flashes lighting up the image which were characteristic of this epoch by means of which, as one might say, there appeared to us to be included in a new way, imaginary beings, by means of which suddenly something guided their meaning properly speaking, became clear by means of a grasp which we cannot better qualify than by (8) designating them by the term Begriff, a clinging grasp, where planes stick together, the function of fixation, of some Haftung or other which is so characteristic of our relationship in this imaginary field, at the same time evoking a dimension of genesis where things are drawn out rather than evolving: a certain ambiguity which allowed the evolutionary schema to be left present, naturally implicated I would say in the field of our discoveries.

How in all this can we say that when all is said and done what characterises this dead time, highlighted by all sorts of

theoreticians and practitioners in the evolution of the doctrine under different headings and titles, could have happened? How did there come about this kind of slow burn which imposes on us, what is properly speaking our object here, the one in which I am attempting to guide you, of taking up again our whole dialectic on surer principles? It would be well for us to be able to designate somewhere the source of the going astray which means that in short we can say that after a certain time these glimpses only remain alive for us if we refer back to the time of their emergence, and this all the more so on the plane of the efficacy of our technique, in the effect of our interpretations, in what makes them efficacious. Why have the imagos discovered by us been in a way banalized?

Is it only through a sort of effect of familiarity? We have learned to live with these ghosts, we are shoulder to shoulder with the vampire, the octopus, we live and breathe in the space of the maternal womb at least metaphorically. The comics for (9) their part also with a certain style, the funny drawing, make these images live for us in a way that was never seen in other ages, carrying with them even the most primordial images of analytic revelation and making of them a day-to-day object of amusement: on the horizon the spineless display and the function of the Great Masturbator preserved in the images of Dali.

Is it because of that alone that our mastery seems to weaken in the instrumental use of these images as revelatory? It is surely not that alone, for projected - as I might say - here into the creations of art, they still preserve what I would call not only their striking but their critical force, they preserve something of their character of derision or alarm but this is not what is in question in our relationship to the person who designates them for us in the actuality of the treatment.

Here the only plan of action that remains to us is the duty of doing good, making people laugh being a very occasional and limited way of using it. And here what we have seen happening, is nothing other than an effect of what one could call a collapse or a degradation, the fact is that we have seen these images returning quite simply to what has been designated very well as a type of archetype, namely old rope from the store of accessories in use. It is a tradition which is very well known under the name of alchemy or of gnosis, but which was linked precisely to a very ancient confusion and which was the one that the field of human thought remained entangled in for centuries.

(10) It might seem that I am marking myself off from or that I am putting you on your guard against a mode of understanding our reference points which is that of Gestalt. Its not quite that. I am far from underestimating what was contributed, at a moment in the history of thought, by the function of the Gestalt; but in order to express myself quickly and because here I am carrying out this kind of clearance of our horizon that I have to carry out again from time to time in order to avoid precisely the same confusions always re-emerging, I would introduce in order to make myself understood this distinction: what constitutes the core of

some of the productions of this mode of exploring the field of the Gestalt, what I would call crystallographic Gestalt, the one which puts the stress on these points of junction, of kinship, between natural formations and structural organisations, in so far as they arise and are definable only from the signifying combinatory, is what gives the subjective force, the efficacy of this point which, for its part, is ontological in which there is delivered to us something of which we in effect have a real need which is to know whether there is a relationship which justifies this introduction as a sort of ploughshare of the effect of the signifier in the real.

But this does not concern us. Because it is not the field that we have to deal with; we are not here to judge the degree of naturalness in modern physics, even though it may interest us - this is what I do from time to time before you sometimes - to show that historically it is precisely in the measure that it completely neglected the naturalness of things that physics began to enter into the real.

(11) The Gestalt against which I put you on your guard, is a Gestalt which, you will observe, in opposition to what the initiators of the Gestalt theory were attached to, gives a purely confusing reference to the function of the Gestalt which is the one that I am calling the anthropomorphic Gestalt, the one which in any way whatsoever confuses what our experience contributes with the old analogical reference of the macrocosm and the microcosm, of the universal man, rather abbreviated registers when all is said and done and which analysis in so far as it believed it could be at home in them only shows once again its relative infecundity. That does not mean that the images, which I humorously evoked above, do not carry a certain weight, nor that they are not there for us still to make use of them. For ourselves the fashion in which for some time we have preferred to leave them hidden, in the shade, ought to be indicative; they are scarcely spoken about any more, except from a certain distance; they are there, to use a Freudian metaphor like one of these shades which are ready to rise up from hell. We have not really known how to reanimate them, we have no doubt not given them enough blood to drink. But after all so much the better, we are not necromancers.

It is precisely here that there is inserted this reminder which is characteristic of what I am teaching you, which is there to completely change the appearance of things, namely to show that the living core of what the Freudian discovery contributed did not consist in this return of old ghosts, but in another

(12) relationship. Suddenly this morning, I rediscovered, from the year 1946, one of these little "Propos sur la causalite psychique" with which I made my re-entry into the psychiatric circle immediately after the war and there appears in this little text here (a text which appeared in connection with the Bonneval conversations), as a sort of apposition or incidence at the beginning of the same concluding paragraph, five lines before finishing what I had to say about the imago: "More inaccessible to our eyes made for the signs of the changer" which leads to

what follows: "than that of which the hunter in the desert", I say - which I only evoke because we came across him the last time, if I remember correctly - "knows how to see the imperceptible trace: the footprint of the gazelle on the rock, one day the aspects of the imago will be revealed".

The accent is to be put for the moment on the beginning of the paragraph "more inaccessible to our eyes..." What are these signs of the changer? What signs and what change or what changer?

These signs, are precisely what I have summoned you to articulate as signifiers, namely these signs in so far as they operate properly in virtue of their associativeness in the chain, of their commutativity, of the function of permutation taken as such. And here is where the function of the changer is: the introduction into the real of a change which is not at all one of movement nor of birth nor of corruption and of all the categories of change which a tradition which we call Aristotelian sketches out, that of knowledge as such, but of another dimension where the change that is in question is defined as such in the topological combinatory which it allows us to define as the (13) emergence of this fact, of the fact of structure, as degradation on occasion, namely the collapse in this field of the structure and the return to the capture of the natural image.

In short, there is sketched out as such something which is only after all the functional framework of thinking, you are going to say. And why not? Let us not forget that this word thinking is present, accentuated from the beginning by Freud, as no doubt not being able to be other than it is, to designate what is happening in the unconscious. Because it was certainly not the need to preserve the privilege of thinking as such, of some primacy or other of the spirit which could have guided Freud here. Far from it: if he had been able to avoid this term, he would have done it. And what does that mean at this level? And why is it that this year I thought I should start, not even from Plato without mentioning the others, but moreover not from Kant, not from Hegel, but from Descartes? It is precisely to designate what is in question, where the problem of the unconscious is for us, it is about the autonomy of the subject in so far as it is not alone preserved, as it is accentuated as it never was in our field and precisely about this paradox that these pathways that we discover in it are in no way conceivable if properly speaking it is not the subject who is their guide and that in a fashion which is all the more sure because it is without knowing it, without being an accomplice to it, as I might say: "conscius", because he cannot progress towards anything nor in any way except only by locating it retrospectively, because there is nothing that is not engendered by him except precisely in the measure that he fails to recognise it at first.

(14) This is what distinguishes the field of the unconscious, as it is revealed to us by Freud. It is itself impossible to formalise, to formulate if we do not see that at every instant it is only conceivable by seeing in it, and in the most obvious and

tangible fashion, this autonomy of the subject preserved, I mean that by which the subject cannot in any circumstances be reduced to a dream of the world. I show you the reference and not the presence of this permanence of the subject. Because this presence cannot be circumscribed except in function of this reference: I demonstrated, designated it for you the last time in this unary trait, in this function of the stroke as figure of the one in so far as it is only the distinctive trait, the trait precisely all the more distinctive in so far as there is effaced from it almost everything which distinguishes it, except the fact of being a trait by accentuating this fact that the more alike it is, the more it functions, I am not saying as a sign, but as a support for difference, and this only being an introduction to the throwing into relief of this dimension that I am trying to punctuate before you. Because in truth there is no longer any folds ("plis"): there is no ideal of similitude, of the ideal of the effacing of traits. This effacing of qualitative distinctions is only there to allow us to grasp the paradox of radical otherness designated by the trait, and it is after all of little importance that each of these traits resembles one another. It is elsewhere that there resides what I called just now this function of otherness. In ending my discourse the last time I highlighted what its function was, the one which assures to repetition precisely the following that by this function, by it alone, this repetition escapes from the identity of its eternal return under the figure of the hunter notching the number (15) of what? Of traits that he wounded his prey, or of the divine Marquis who shows us, that even at the summit of his desire, he takes good care to count these ejaculations, and that this is an essential dimension, in so far as it never abandons the necessity that it implies in almost any of our functions.

In counting these events, the trait which counts, what is it?
Are you still following me properly here?

Grasp carefully what I intend to designate, it is the following whose source is easily forgotten: it is that what we are dealing with in the automatism of repetition is the following: a cycle in however amputated, deformed, abraded way we may define it: once it is a cycle and once it involves a return to a terminal point, we can conceive of it on the model of need, of satisfaction. This cycle is repeated; it does not matter whether it is altogether the same or whether it presents tiny differences, these tiny differences will manifestly only be constructed in order to conserve it in its function of cycle as referring to something definable as a certain type through which precisely all the cycles which preceded it are identified in the very instant as being, in so far as they are reproduced, properly speaking the same. Let us take to depict what I am in the process of telling you the cycle of digestion: every time we go through one, we repeat digestion. Is this what we are referring to when we speak, in analysis, of the automatism of repetition? Is it in virtue of an automatism of repetition that we go through (16) digestions which are tangibly always the same digestion?

I will not leave you the opening of saying that up to this it is

a sophism. There can be naturally incidents in this digestion which are due to the reminders of old digestions which were disturbed: effects of disgust, of nausea, linked to one another contingent linking of such a food with such a circumstance.

This will not for all that help us to make a step further in the distance to be covered between this return of the cycle and the function of the automatism of repetition. Because what the automatism of repetition means in so far as we have to deal with it, is the following: the fact is that if a determined cycle which was only that very one - it is here that there is outlined the shadow of the "trauma" which I am putting here only in inverted commas, because it is not its traumatic effect that I hold onto but only its uniqueness - this one therefore which is designated by a certain signifier which can only be supported by what we will subsequently learn to define as a letter, the agency of the letter in the unconscious this big A, the initial A in so far as it is numberable, that this cycle here, and not another is equivalent to a certain signifier, it is in this sense that the behaviour repeats itself in order to make re-emerge this signifier that it is as such, this number that it grounds.

If for us symptomatic repetition has a meaning towards which I am redirecting you, reflect on the import of your own thinking. When you speak about repetitive incidence in symptomatic formation, it is in so far as that which is repeated is there, not even just to fulfil the natural function of the sign which is (17) to represent something which is supposed to be actualised here, but to presentify as such the signifier that this action has become.

I am saying that it is in so far as what is repressed is a signifier that this cycle of real behaviour is presented in its place. It is here, since I have imposed on myself to give a precise and convenient time limit for a certain number of you to what I should present before you, that I will stop. As for the confirmation and the commentaries that all of this requires, you can count on me to give them to you in what follows in the most appropriately articulated fashion, however astonishing their abruptness may have appeared to you, when I exposed them to you just now.

Seminar 6: Wednesday 20 December 1961

The last time I left you on a remark designed to give you the sense that my discourse is not losing its moorings, namely that the importance, for us, of this research this year depends on the fact that the paradox of the automatism of repetition is that you see arising a cycle of behaviour inscribable as such in terms of a resolution of tension, therefore of the need-satisfaction couple, and that nevertheless whatever may be the function involved in this cycle, however carnal you may suppose it to be, it nevertheless remains that what it means qua automatism of repetition is that it is there in order to make emerge, to recall, to make insist something which is nothing other in its essence than a signifier which can be designated by its function, and especially under this aspect that it introduces into the cycle of its repetitions - always the same in their essence and therefore concerning something which is always the same thing - difference, distinctiveness, unicity, and that it is because something happened at the origin which is the whole system of the trauma, namely that at one time there was produced something which took on from that time the form A, that in the repetition the behaviour however complex, engaged you may suppose it to be in the animal individuality, is only there in order to make (2) re-emerge this sign A. Let us say that the behaviour from then on is expressible as behaviour number such and such; it is this behaviour number such and such, let us say it, the hysterical access for example: one of the forms in the case of a particular subject are his hysterical accesses, and it is this which emerges as behaviour number such and such. Only the number is lost for the subject. It is precisely in so far as the number is lost that there emerges this behaviour masked in this function of giving rise to the number behind what will be called the psychology of his access, behind the apparent motivations; and you know that in this regard no one will find it difficult to find an apparent reason for it: it is proper to psychology always to make a shadow of motivation appear.

It is therefore with this structural sticking together of something radically inserted into this vital individuality with this signifying function, that we are in analytic experience (Vorstellungsrepräsentanz): this is what is repressed, it is the lost number of behaviour such and such.

Where is the subject in all of that?

It is in the radical, real individuality, in the pure sufferer of this capture, in the organism which henceforward is sucked in by the effects of the "it speaks" (ça parle) by the fact that one living being among the others was summoned to become what Mr Heidegger calls the shepherd of being, having been caught up in the mechanisms of the signifier. Is it at the other extreme identifiable to the very operation of the signifier? And is not the subject only the subject of discourse who is in some way torn away from his vital immanence, condemned to fly on high, to live (3) in this sort of mirage which flows from this redoubling which ensures that he not only speaks everything he lives, but that he experiences living being by speaking it and that already what he is living is inscribed in an epos, a Saga woven right throughout his very act.

Our effort this year if it has a meaning, is precisely to show how the function of the subject is articulated elsewhere than in one or other of these poles, that it operates between the two. It is after all - I for my part imagine - what your cogitation - at least I like to think so - after these few years of seminars may give you, even if only implicitly, as a reference point at every instant. Is it enough to know that the function of the subject is in the between-the-two, between the idealising effects of the signifying function and this vital immanence which you may too readily confuse, I still think, despite all my warnings, with the function of the drive? It is precisely what we are engaged in and what we are trying to push further, and the reason why also I thought I should begin with the Cartesian cogito in order to make tangible the field in which we are going to try to give more precise articulations about identification.

I spoke to you, a few years ago, about little Hans; there is in the story of little Hans - I think that you have kept the memory of it somewhere - the story of the dream which one can pinpoint with title of the crumpled (verwurzelt) giraffe. This verb verwurzeln which has been translated by to crumple, is not a very (4) common verb in the usual German lexicon. Though wurzeln is found there, verwurzeln is not. Verwurzeln means: to make a ball. It is indicated in the text of the dream of the crumpled giraffe that it is a giraffe which is there next to the big living giraffe, a paper giraffe and that as such one can make a ball of it. You know the whole symbolism which is unfolded right through this observation, of the relationship between the big giraffe and the little giraffe, the crumpled giraffe under one of its aspects, conceivable under the other as the reduced giraffe, as the second giraffe, as the giraffe which can symbolise many things. If the big giraffe symbolises the mother, the other giraffe symbolises the daughter; and the relationship of little Hans to the giraffe, at the point that we are at at that moment of his analysis, will tend to be incarnated rather readily in the living interplay of family rivalries.

I remember the astonishment - it would no longer be appropriate today - that I provoked at that time by designating at that very moment in the case of little Hans as such, the dimension of the symbolic in act in the psychical productions of the young subject

in connection with this crumpled giraffe. What could be more indicative of the radical difference of the symbolic as such, than to see appearing in the production, certainly not suggested on this point - because there is no trace at that moment of any such articulation concerning the indirect function of the symbol - than to see in the observation something which really incarnates for us and images the advent of the symbolic as such in the psychical dialectic. "Really, where did you find it" one of you kindly said to me after that session?

(5) The surprising thing is not that I saw it because it would be difficult to have it indicated more crudely in the material itself, it is that at that place one could say that Freud himself does not dwell on it, I mean does not give at all the stress that would be appropriate to this phenomenon, to what materialises it, as one might say, to our eyes. This indeed is what proves the essential character of these structural delineations, it is by not making them, by not highlighting them, by not articulating them with all the energy of which we are capable, it is a certain aspect, a certain dimension of the phenomena themselves that we condemn ourselves in a way to overlook.

I am not going to go over again for you on this occasion the articulation of what was involved, of what was at stake in the case of little Hans. These things have been published enough and well enough for you to be able to refer to them. But the function as such at this critical moment - the one determined by his radical suspension on the desire of the mother, in a fashion which, as one might say, has nothing to off-set it, is irretrievable, inescapable - is the function of artifice which I showed you to be that of the phobia in so far as it introduces a key signifying mainspring which allows the subject to preserve what is in question for him, namely the minimal anchoring, centering of his being, which allows him not to sense himself as a being who is completely adrift at the whim of his mother. This is what is at stake, but what I want to highlight at this level is the following: it is that in a production which can scarcely be considered unreliable on this occasion - I say it all the more because everything towards which little Hans had previously been directed (because God knows he was directed as I showed you -

(6) nothing of all of this is of a nature to put him into the field of this type of elaboration; little Hans shows us here in a figure which is certainly obscure, but exemplary, the leap, the passage, the tension between what I defined first of all as the two extremes of the subject: the animal subject which represents the mother, but also with its long neck, no one has any doubt about it, the mother in so far as she is this immense phallus of desire ending again in the browsing mouth of this voracious animal, and then on the other something on a paper surface. We will return to this dimension of surface, something which is not without a subjective accent; because one sees well the whole import of what is involved: the big giraffe, when she sees him playing with the small crumpled one, cries out very loudly until finally she grows weary, her cries are exhausted, and little Hans, sanctioning in a way the taking possession, the Besitzung of what is involved, the mysterious import of the affair, by

sitting on top of it (darauf gesetzt).

This lovely mechanism ought to make us sense what is involved, since indeed it concerns his fundamental identification, the defence of himself against this original capture within the world of the mother, as no one of course doubts, at the point that we are at in elucidating phobia. Here already we see exemplified this function of signifier. It is indeed here that I want to pause again today on the point of departure of what we have to say about identification. The function of the signifier in so far as it is the mooring point of something from which the subject constitutes himself, here is something which is going to (7) make me dwell for a moment today on something which, it seems to me, should come quite naturally to mind, not just for reasons of general logic, but also because of something that you should touch on in your experience: I mean the function of the name (nom), not the noun (nom), the noun defined grammatically, what we call the substantive in our schools, but the name in the way that in English - and what is more, in German - the two functions are distinguished. I would like to say a little more about it here, but you will understand the difference: the name, is the proper name. You know as analysts, the importance that the proper name of the subject has in every analysis. You should always pay attention to what your patient is called. It is never indifferent. And if you ask for names in analysis, it is indeed something much more important than the excuse that you may give for it to the patient, namely that all sorts of things may hide themselves behind this sort of dissimulation or effacing of a name, concerning the relations that it may bring into play with some other subject.

It goes much further than that; you should sense it even if you do not know it.

What is a proper name?

Here we should have a lot to say. The fact is that in effect we could bring a lot of material to the name. This material, we analysts, even in supervision, we would have a thousand opportunities to illustrate its importance. I do not believe (8) that we could here precisely give it all its import - this is a further occasion to put your finger on a methodological necessity - without referring to what the linguist has to say in this respect, not necessarily to submit ourselves to it, but because as regards the function, the definition of this signifier which has its own originality, we should at least find in it a control, if not a complement to what we can say.

In fact, this indeed is what is going to happen. In 1954 there appeared a little factum by Sir Allan H. Gardiner. There are all sorts of works by him and in particular a very good Egyptian grammar - I mean one of antique Egypt - he is therefore an Egyptologist, but he is also and above all a linguist. Gardiner produced - it was at that time that I acquired it during a short trip to London - a very small little book called The theory of proper names. He produced it in a rather contingent fashion.

He calls it himself a "controversial essay", un essai controversiel. One could even say that this is a litotes: a polemical essay. He wrote it because of the extreme exasperation he had felt at a certain number of enunciations of a philosopher whom I am not indicating to you for the first time: Bertrand Russell whose enormous role in the elaboration of what one could call in our days mathematicised logic or logicised mathematics you know about. In the Principia mathematica with Whitehead, he gave us a general symbolism of logical and mathematical operations which one cannot fail to take into account, once one enters into this field. Russell then, in one of his works, gives (9) a certain definition which is quite paradoxical - the paradox moreover is a dimension in which he is far from reluctant to move about in, on the contrary: he makes use of it more often than it deserves - Mr Russell put forward then certain remarks about the proper name which literally put Mr Gardiner beside himself. The quarrel is in itself significant enough for me to think that today I should introduce you to it and in this connection hook onto it remarks that I think are important.

What end are we going to start with, with Gardiner or with Russell?

Let us begin with Russell.

Russell finds himself in the position of the logician; the logician has a position which does not date from yesterday. He brings into operation a certain apparatus to which he gives different titles: reasoning, thinking. He discovers in it a certain number of implicit laws. In a first phase he separates out these laws: they are the ones without which nothing which belongs to the order of reason would be possible. It is in the course of this quite original research into the thinking which governs us, by reflection, that we grasp for example the importance of the principle of contradiction. This principle of contradiction having been discovered, it is around the principle of contradiction that something unfolds and is organised, which undoubtedly shows that if contradiction and its principle were not something tautological, tautology would be singularly fruitful; because Aristotelian logic cannot be unfolded in a few (10) pages.

With time, nevertheless, the historical fact is that even though the development of logic is directed towards an ontology, a radical reference to being which is supposed to be aimed at in these most general laws of the mode of understanding necessary for truth, it orients itself towards a formalism, namely that that to which the leader of a school of thought as important, as decisive in the orientation that it has given to a whole mode of thinking in our epoch as Bertrand Russell, should have managed to put everything that concerns the critique of the operations brought into play in the field of logic and of mathematics, into a general formalisation that is as strict, as economical as possible.

In short, the correlative effort of Russell, the thrust of

Russell's effort in the same direction, in mathematics, culminates at the formation of what is called set theory, whose general import one can characterise in the fact that an effort is made in it to reduce the whole field of mathematical experience accumulated throughout centuries of development, and I believe that a better definition of it cannot be given than to reduce it to an interplay of letters (jeu de lettres). We should take this into account then as a given in the progress of thinking; let us say, at our epoch, this epoch being defined as a certain moment of the discourse of science.

What is it then that Bertrand Russell finds himself led to give in these conditions, when he comes to interest himself in it, as a definition of a proper name?

(11) It is something which in itself is worthwhile dwelling on, because it is what is going to allow us to grasp - it could be grasped elsewhere, and you will see that I will show you that it is grasped elsewhere - let us say the degree of miscognition (méconnaissance) implied in a certain position which is found to be effectively the corner into which there is pushed the whole age-old effort of the elaboration of logic. This miscognition is properly speaking something which no doubt I put before you in a way from the beginning of what I have to pose here because of the requirements of my exposition: this is precisely the miscognition of the thinking subject's most radical relationship to the letter. Bertrand Russell sees everything, except this: the function of the letter. This is what I hope to be able to make you sense and to show you. Have confidence and follow me. You are going to see now how we are going to advance. What does he give as a definition of the proper name? A proper name is, he says, "word for particular" a word to designate particular things as such. Now, in every description there are two ways of approaching things: to describe them by their quality, their reference-points, their co-ordinates from the point of view of the mathematician, I mean to designate them as such. This point, for example, let us say that here I can tell you: it is on the right of the blackboard, at such a height more or less, it is white and so on and so on. That is a description, Mr Russell tells us. These are the ways of designating it, outside of any description, as particular: that is what I am going to call proper name.

(12) The first proper name for Mr Russell - I already alluded to it in my preceding seminars - is the "this", celui-ci (this is the question). Here the demonstrative has passed to the rank of proper name. It is no less paradoxical that Mr Russell coolly envisages the possibility of calling this same point John. It must be recognised that we have all the same here a sign that perhaps there is something which goes beyond experience; because the fact is that it is rare for one to call a geometrical point John. Nevertheless Russell has never retreated from the most extreme expressions of his thought. It is all the same here that the linguist becomes alarmed, becomes all the more alarmed because between these two extremes of Russell's definition "word for particular", there is this altogether paradoxical consequence

that, being logical with himself, Russell tells us that Socrates has no right to be considered by us as a proper name, it being given that for a long time now Socrates is no longer a particular. I am abbreviating what Russell says, I am even adding a touch of humour to it, but it is indeed the spirit of what he tells us, namely that Socrates was for us Plato's master, the man who drank the hemlock, etc... It is an abbreviated description; it is therefore no longer as such what he calls a word to designate the particular in its particularity.

It is quite certain that we see here that we are completely losing any of the advantages that a linguistic consciousness gives us, namely that, if we have to eliminate everything that in proper names is inserted into a community of the notion, we arrive at a sort of impasse which is indeed that against which Gardiner tries to oppose properly linguistic perspectives as (13) such.

What is remarkable, is that a linguist who does not lack merit or experience or skill, because of an experience of the signifier that is all the more profound in that it is not for nothing that I pointed out to you that he is someone whose work in part unfolded in an especially suggestive and rich angle of experience which is that of hieroglyphics since he is an Egyptologist, is going, for his part, to be led to counter-formulate for us what appears to him to be characteristic of the function of the proper name.

He is going to elaborate this characteristic of the function of the proper name for us by referring himself to John Stuart Mill and to a Greek grammarian of the second century before Christ, called Dionysius Thrax.

Curiously, he is going to encounter in them something which, without ending up in the same paradox as Bertrand Russell, takes into account formulae which at first sight could appear as homonymie as one might say. The proper name, "idion choluon", moreover is only the translation of what the Greeks and specifically this Dionysius contributed on this point, idion as opposed to choluon. Is idion here to be confused with the particular, in Russell's sense of the term? Certainly not, because this is not what Mr Gardiner would have taken as a support, if what he were to find there was an agreement with his adversary. Unfortunately, he does not manage to specify^ the difference here between the term of ownership (propriété*) as implied in what distinguishes the original Greek point of view, (14) and the paradoxical consequences that a certain formalism arrives at. But under the shelter of the progress that the reference to the Greeks, then to Mill who is closer to him, fundamentally allows him, he highlights the following which is what is involved, namely what it is that functions in the proper name which allows us immediately to distinguish it, to spot it as such, as a proper name. With a good deal of pertinence. Mill, in approaching the problem puts the accent on the following: the fact is that the way a proper name is distinguished from a common noun, is from the angle of something which is at the level of

meaning; the common noun appears to concern the object in so far as it brings a meaning with it. If something is a proper name, it is in so far as it is not the meaning of the object that it brings with it, but something which is of the order of a brand applied in a way to the object, superimposed on it, and which by this fact will be all the more in close solidarity if it is less open, because of the absence of meaning, to any participation in a dimension by which this object goes beyond itself, communicates with other objects. Mill here makes intervene moreover, brings into play a sort of little apologue linked to a story: the coming into play of an fantasy-image. It is the story of the role of the fairy Morgiana who wants to preserve some of her protege's from some plague or other that is destined for them because of the fact that in the town a chalk mark had been put on their doors. Morgiana helps them avoid succumbing to the effect of the exterminating plague by putting the same mark on all the other houses of the same town.

Here Sir Allan Gardiner has no trouble in demonstrating the miscognition that is implied in this apologue itself; it is that (15) if Mill had had a more complete notion of what was involved in the incidence of the proper name, he should not only have taken into account the identificatory character of the mark when it was being forged, but also its distinctive character, and as such the apologue would be more suitable if one were to say that the fairy Morgiana had also to mark the other houses with a sign in chalk, but one different from the first so that the person who comes into the town to fulfill his mission, searching for the house where he must bring to bear his fatal incidence, no longer knows how to find the sign that is in question, for want of knowing in advance precisely what sign among others is to be searched for.

This leads Gardiner to an articulation which is the following: in an obvious reference to this distinction of the signifier and the signified, which is fundamental for every linguist even if he does not put it forward as such in his discourse, Gardiner remarks - not unjustifiably - that it is not so much the absence of meaning that is involved in the usage of the proper name. Because moreover everything tells us that the opposite is the case: very often proper names have a meaning. Even M Durand, that has a meaning; Mr Smith means a smith and it is quite clear that it is not because Mr Smith may be perchance a smith that his name will be any the less a proper name. What constitutes the usage of the proper name, on this occasion of the word smith, Mr Gardiner tells us, is that the accent in its usage is put, not on the meaning, but on the sound qua distinctive. There is here obviously a very great advance of dimensions, which in most cases will allow us to perceive in practice that something functions (16) more especially as a proper name. Nevertheless, it is all the same rather paradoxical precisely to see a linguist whose first definition of his material, the phonemes, is that they are precisely sounds which are distinguished from one another, giving as a particular trait to the function of the proper name that it is precisely because of the fact that the proper name is composed of distinctive sounds that we can characterise it as a proper

name. Because of course, from a certain angle it is obvious that every use of language is precisely based on this: the fact is that a language is composed of a material which is that of distinctive sounds. Naturally this objection does not fail to appear to the author himself of this elaboration. It is here that he introduces the subjective notion - in the psychological sense of the term - of the attention accorded to the signifying dimension which is here the sonant material. Observe carefully that what I am highlighting here, is that the linguist who ought to strive to put to one side - I am not saying to totally eliminate from his field - anything which is a properly psychological reference, is all the same led here as such to take into account a psychological dimension as such, I mean that because of the fact that the subject, as he says, invests, pays special attention to what is the body of his interest when it is a question of a proper name. It is in so far as it carries a certain sonant difference that it is taken as a proper name, remarking that on the contrary in common discourse, what I am in the process of communicating for example to you at the moment, I am paying absolutely no attention to the sonant material of what I am telling you. If I paid too much attention to it I would soon see my discourse being killed off and drying up, I am trying (17) first of all to communicate something to you. It is because I believe that I know how to speak French that the material which is effectively distinctive in its essence, comes to me; it is there as a vehicle to which I pay no attention; I am thinking of the goal that I am going to, which is to get across to you certain qualities of thinking that I am communicating to you.

Is it as true as all that that each time that we pronounce a proper name we are psychologically aware of the accent put on the sonant material as such? It is absolutely not true. I no longer think about the sonant material, Sir Allan Gardiner, when I am speaking to you about it any more than when I am speaking to you about verwurtzeln or anything else whatsoever. Already my examples here are badly chosen because these are already words which I highlight as words by writing them on the blackboard. It is certain that whatever may be the value of the claim of the linguist here, it fails very specifically, in so far as it believes it has no other reference to bring into play except the psychological one. And it comes to grief on what?

Precisely in articulating something which is perhaps indeed the function of the subject, but of the subject defined completely differently than by anything whatsoever which is of the order of concrete psychology, of the subject in so far as we could, as we must, as we will define it properly speaking by its reference to the signifier. There is a subject which is not confused with the signifier as such, but which is unfolded in this reference to the signifier with traits, characters which are perfectly articulatable and formalisable and which ought to permit us to (18) grasp, to discern as such the idiotic character - if I take up the Greek reference, it is because I am far from confusing it with the use of the word "particular" in Russell's definition - the idiotic character as such of the proper name. Let us try now to indicate in what sense I intend to make you grasp it.

In the sense in which for a long time I have been bringing into play at the level of the definition of the unconscious, the function of the letter. I brought this function of the letter into play for you first of all in a sort of poetic fashion; the seminar on the "purloined letter", in our very first years of elaboration, was there to indicate for you that something was to be taken well and truly in the literal sense of the term letter because it involved a missive, something that we could consider as being determining right into the psychical structure of the subject: a fable no doubt but one which rejoined the most profound truth in its structure as fiction. When I spoke about "The agency of the letter in the unconscious" a few years later, I gave by means of metaphors and metonymies a more precise accent to it. We are arriving now, with this beginning we have made about the function of the unary trait, at something which is going to allow us to go further: I am posing that there cannot be a definition of the proper name except in the measure that we are aware of the relationship between the naming utterance and something which in its radical nature is of the order of the letter. You are going to say to me: here then there is a great difficulty, because there are many people who do not know how to read and who make use of proper names; and then proper names (19) with the identification they determine existed before the appearance of writing. It is under this heading, under this register, "man before writing" that there has appeared a very good book which gives us the very last word on what is currently known about human evolution before history. And then how will we define ethnography about which certain people thought it plausible to advance that it was a matter properly speaking of everything that in the order of culture and of tradition is unfolded outside any possibility of documentation using the tool of writing.

Is it as true as all that?

There is a book which I can ask all of those who are interested by this - and already some people have anticipated my indication - to consult: it is the book by James Février on the history of writing. If you have the time during the holidays, I would ask you to refer to it. You will see there clearly being laid out there something whose general principle I indicate to you because in a way it is not fully separated out and it is everywhere present: it is that prehistorically speaking, if I can express myself in this way, I mean in the whole measure that the stratographic layers of what we find bear witness to a technical and material evolution of human accessories, prehistorically everything that we can see about what happens in the advent of writing and therefore in the relationship of writing to language, everything happens in the following fashion whose result is here posed, articulated very precisely before you, everything happens in the following fashion: without any doubt we can admit that man, ever since he has been man, as a speaker has had vocal (20) utterance. On the other hand, there is something which is of the order of these traits in connection with which I told you of the emotion of admiration that I experienced in rediscovering them marked in a little row on what seemed to be the rib of an

antelope. There is in the prehistorical material an infinity of manifestations of traces which have no other character than that of being, like this trait, signifiers and nothing more. People speak about ideograms or about idéographies, what does that mean?

What we always see every time that one can bring into play this label of ideogram, is something which presents itself as being in effect very close to an image, but which becomes an ideogram in the measure that it loses, that it effaces more and more this character of image. Such is the birth of cuneiform writing: it is for example a bouquetin's limb or head, in so far as after a certain moment this takes on an aspect for example like the following for the arm:

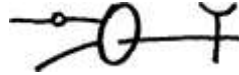

namely nothing about its origin is recognisable anymore. That transitions exist here, has no importance other than to strengthen us in our position, namely that what is created, at some level where we see writing emerging, is a baggage, a battery of something which one has no right to call abstract, in the sense that we employ it in our own day when we speak about abstract painting. For they are in effect traits which emerge from something which in its essence is figurative; and that is the reason why it is believed that it is an ideogram. But it is something figurative that is effaced, let us say the word which necessarily comes here to our minds: repressed, even rejected. (21) What remains is something of the order of this unary trait in so far as it functions as distinctive, that it can on occasions play the role of brand. You are not unaware - or you are unaware, it does not matter - that at the Mas d'Azil, another site dug by Piette of whom I spoke to you the other day, pebbles and stones were found on which you see things like the following for example:



This would be in red, for example, on rather polished type of stones which have taken on a greenish colour. On another one you will even plainly see this £ which is all the more polished in that this sign, £ is what is used in set theory to designate the belonging of an element; and there is another one of them: when you look at it from a distance it is a dice; one sees five points, from the other you see two points, when you look from the other side it is again two points, it is not a dice like the ones we have and if you ask the curator, if you have the glass case (22) opened for you, you see that on the other side of the five there is a bar, a 1. It is therefore not altogether a dice, but it has an impressive appearance at first sight so that you might have thought that it was a dice. And when all is said and done you would not be wrong, because it is clear that a collection of moveable characters - as we can describe them - of this kind is something which in any case has a signifying function. You will

never know what that was used for, if it was for drawing lots, if they were objects of exchange, tesseræ properly speaking, objects of recognition or whether that was used for anything whatsoever that you can lucubrate on in terms of mystical themes. That changes nothing in the fact that what you have here are signifiers.

That the aforesaid Piette should have subsequently drawn Salomon Reinach into deliberating the tiniest little bit about the extremely archaic and primordial character of occidental civilisation because supposedly this is already an alphabet, is another affair: but this is to be judged as a symptom, but also to be criticized for its real import. That nothing of course allows us to speak about an extremely archaic writing in the sense that these moveable characters would have been used to make a sort of cave printing press, this is not what is in question. What is in question is the following in so far as one or other ideogram means something: to take the little cuneiform character that I drew for you earlier, this at the level of a very primitive stage of Accadian writing designates the heavens, there results from this that it is articulated "an"; the subject who looks at this ideogram names it "an" in so far as it represents the heavens. But what is going to result from it is that the (23) position is reversed, that from a certain moment on this ideogram of the heavens is going to be used in a writing of a syllabic type, to support the syllable "an" which will at that time no longer have any relationship with the heavens. All ideographic or so-called ideographic writings without exception, carry the trace of the simultaneity of this use which is called ideographic with what is called the phonetic usage of the same material.

But what is not articulated, what is not highlighted, what it seems nobody has dwelt on up to now is the following: it is that everything happens as if the signifiers of writing having first of all been produced as distinctive marks, and we have historical attestations of this, because someone called Sir Flanders Petrie showed that well before the birth of these hieroglyphic characters, on the pottery which remains to us from what is called predynastic industry, we find as a brand on the pottery more or less all the forms which are found to be used subsequently, namely after a long historical evolution in the Greek, Etruscan, Latin, Phoenician alphabets everything that interests us to the highest degree as being characteristics of writing. You see what I am trying to get to. Even though in the final analysis what the Phoenicians at first, then the Greeks did most admirably, namely this something which allows a notation apparently as strict as possible of the functions of the phoneme with the help of writing, it is from a completely contrary perspective that we should see what is in question. Writing as material, as baggage, was waiting there - following on a certain process to which I will return: that of the formation, let us say (24) of the brand, which today incarnates the signifier that I am speaking to you about: writing was waiting to be phoneticised and it is in the measure that it is vocalised, phoneticised like other objects, that writing learns, as I might say, to function

as writing. If you read this work on the history of writing you will find at every instant the confirmation of what I am giving you here as a schema. Because every time there is a progress in writing it is in so far as a population tried to symbolise its own language, its own phonematic articulation with the help of a writing material borrowed from another population, and which was only in appearance well adapted to another language - because it was not better adapted, it is never well adapted of course, because what relationship is there between this modulated and complex thing and a spoken articulation - but which was adapted by the very fact of the interaction that there is between a certain material and the usage that is given to it in another form of language, of phonematic, of syntax, whatever you wish, namely that it was in appearance the least appropriate instrument at the beginning for what one had to make of it.

In this way there takes place the transmission of what is first of all forged by the Sumerians, namely before it arrives at the point that we are at here; and when it is picked up by the Accadians all the difficulties come from the fact that this material fits in very badly with the phonematics that it has to enter into, but on the contrary once it has entered into it, it influences it as far as we can see and I will have to come back on this. In other words, what the advent of writing represents is the following: that something which is already writing if we consider that the characteristic is the isolation of the (25) signifying trait, when it is named, manages to be able to serve as a support for this famous sound on which Mr Gardiner puts the whole accent concerning proper names.

What results from this?

There results from it that we should find, if my hypothesis is correct, something which proves its validity. It has been thought of more than once, there are swarms of them; but the most accessible, the most obvious, is the one that I am going to give you right away, namely that one of the characteristics of the proper name - I will of course have to come back on it and in a thousand forms, you will see a thousand demonstrations of it - is that the characteristic of the proper name is always more or less linked to this trait of its liaison not to the sound, but to the writing; and one of the proofs, the one that today I want to put in the forefront before you, is the following: it is that when we have writings which are undeciphered because we do not know the language that they incarnate, we are very embarrassed, because we have to wait to have a bilingual inscription, and this does still not take us very far if we know nothing at all about the nature of its language, namely about its phonetics.

What are we waiting for when we are cryptographers and linguists; it is to discern in this undeciphered text something which could indeed be a proper name because there is this dimension to which I am astonished Mr Gardiner did not have recourse, he who all the same has Champollion as the chief, the inaugural leader of his (26) science, and that he does not remember that it is in connection with Cleopatra and Ptolemy that the whole deciphering

of the Egyptian hieroglyphs began because in every language, Cleopatra is Cleopatra, and Ptolemy is Ptolemy. What distinguishes a proper name despite little appearances of borrowings - Cologne is called Koln - is that from one tongue to another its structure is preserved, its sonant structure no doubt; but this sonant structure is distinguished by the fact that precisely we should respect it above all others, and this by reason precisely of the affinity of the proper name with the brand, with the direct designation of the signifier as object, and here apparently we fall again and even in the most brutal fashion on the "word for particular". Does that mean that for all that I think Mr Bertrand Russell is correct here? Certainly not as you know. Because in the interval is the whole question precisely of the birth of the signifier starting from that of which it is the sign. What does that mean? It is here that there is inserted as such a function which is that of the subject, not of the subject in the psychological sense but of the subject in the structural sense.

How can we, under what algorithms can we, because it is a question of formalisation, place this subject? Is it in the order of the signifier that we have the means to represent that which concerns the genesis, the birth, the emergence of the signifier itself? It is towards this that my discourse is directed and I will take it up next year.

Seminar 7: Wednesday 10 January 1962

Let us evoke again what I said the last time: I spoke to you about the proper name in so far as we had encountered it on our path towards the identification of the subject, the second, regressive, type of identification to the unary trait of the Other. In connection with this proper name, we have encountered the attention that it has already attracted from a particular linguist and mathematician as they were philosophising.

What is the proper name?

It seems that it is not something which betrays itself at the first approach, but, in trying to resolve this question, we had the surprise of rediscovering the function of the signifier probably in the pure state; it was indeed along this path that the linguist himself directed us when he told us: a proper name is something that takes its value from the distinctive function of its sonant material, in saying which of course, he was only repeating the first fruit of the Saussurian analysis of language: namely that it is the distinctive trait, it is the phoneme as coupled to the totality of a certain battery, in so far uniquely that it is not what the others are, that we find it here as having to designate as what was the special trait of the usage of a subject-function in language: that of naming by one's own name.

(2) It is certain that we could not content ourselves with this definition as such, but that we were for all that put on the track of something, and this something, we were able at least to approach, to circumscribe, by designating the fact that it is, as one might say, in a form latent to language itself, the function of writing, the function of the sign in so far as it itself is read as an object; it is a fact that the letters have names; we have too great a tendency to confuse them with the simplified names that they have in our alphabet which seem to become confused with the phonematic utterance to which the letter has been reduced: an a seems to mean the utterance a, a b is not properly speaking a b, it is only a b in so far as for the consonant b to make itself heard it has be supported by a vocalic utterance. Let us look at things more closely, we will see for example, in Greek, alpha, beta, gamma, and what follows are well and truly names and, a more surprising thing, names which have no meaning in the Greek tongue in which they are formulated; in order to understand them, it must be realized that they reproduce the names corresponding to the letters of the Phoenician

alphabet, of a proto-Semitic alphabet, an alphabet such as we can reconstitute it from a certain number of stages, of strata; from inscriptions we find the signifying forms of it: these names have a meaning either in textual Phoenician, or such as we can reconstitute it, this proto-Semitic tongue from which there are supposed to be derived a certain number - I am not insisting on their detail - of languages to the evolution of which is closely linked the first appearance of writing.

(3) Here, it is a fact that it is important at least that there should come into the foreground the fact that the very name aleph is related to the cow, whose head the first form of aleph supposedly reproduces in a schematised fashion in different positions: something of it still remains: we can still see in our capital A the shape of a cow's skull upside down with the horns which prolong it. Likewise, everyone knows that beth is the name for house. Naturally, the discussion becomes complicated, even obscure when one attempts to make a register, a catalogue of what the name of the other succeeding letters designates: when we arrive at guimel, we are only too tempted to rediscover in it the Arabic name for camel, but unfortunately, there is a time obstacle: it is in the second millenium more or less before our era that these proto-Semitic alphabets might have been in a position to connote this name: the third letter of the alphabet, the camel, unfortunately for our comfort, had not yet made his appearance in the cultural usages of transport in these regions of the Near East.

A series of discussions begins therefore about what this name guimel might represent (here there is a development about the consonantal tertiary of Semitic tongues and about the permanence of this form at the basis of every verbal form in Hebrew). It is one of the traces by which we can see that what is involved as regards one of the roots of the structure in which language is constituted, is this something which is called at first a reading of signs, in so far as already they appear before any use of writing.

(4) I pointed out for you in ending the last time the usage in a surprising fashion, in a fashion which seems to anticipate - if the thing is to be admitted - by approximately a millenium, of the same signs in the most current alphabets, the alphabets which are the direct ancestors of our own: the Latin, Etruscan alphabets etc...:



which are found by the most extraordinary mimicry of history in an identical form in marks on the predynastic pottery of antique Egypt; they are the same signs, even though it is completely out of the question that they could at that moment have been used in any way for alphabetical purposes, alphabetic writing being at that moment far from being born.

You know that, earlier again, I made an allusion to these famous pebbles of the Mas d'Azil which are not the least important of the discoveries made at that place, to the point that at the end

of the Paleolithic era a stage is designated by the term Azilian because it refers to the fact that we can define the point of technical evolution at the end of this Paleolithic era in the not properly speaking transitional, but pre-transitional period of the Paleolithic to the Neolithic.

On these pebbles of the Mas d'Azil, we find analogous signs, whose striking strangeness, resembling so closely the signs of our alphabet was able to lead astray, as you know, minds which were not especially mediocre, into all sorts of speculations (5) which could only lead to confusion, even to ridicule.

It nevertheless remains that the presence of these elements is there to allow us to put our finger on something which is proposed as radical in what we could call the attachment of language to the real, a problem, of course, which is only posed in so far as we have first been able to see the necessity, in order to understand language, to order it through what we could call a reference to itself, to its own structure as such, which first of all posed for us what we could almost call its system, as something which is in no way satisfied by a purely utilitarian, instrumental, practical genesis, by a psychological genesis, which shows us language as an order, a register, a function whose problematic is always for us that we have to see it as capable of functioning outside any consciousness on the part of the subject and whose field as such we are led to define as characterised by structural values which are proper to it. From then on, it is necessary, for us, to establish the junction between its functioning and this something which carries, in the real, its mark: is it centrifugal or centripetal? It is here around this problem that we are for the moment not brought to a halt, but pausing.

It is therefore in so far as the subject, in connection with something which is mark, which is sign, already reads before there is question of the signs of writing, that he perceives that signs can carry on occasions differently reduced, cut-off fragments of his speaking modulation, and that, reversing its (6) function, it can subsequently be admitted to being as such its phonetic support, as they say, if you know that it is in this way that phonetic writing is born, that there is no writing to my knowledge, more exactly, that everything that is of the order properly speaking of writing, and not simply a drawing, is something which begins always with the combined usage of these simplified drawings, of these abbreviated drawings, of these effaced drawings that are in different ways incorrectly called ideograms in particular. The combination of these drawings with a phonetic usage of the same signs which appear to represent something, the combination of the two appears, for example obvious in the Egyptian hieroglyphs. Moreover, we might, just by looking at a hieroglyphic inscription, believe that the Egyptians had no other objects of interest than the quite limited baggage of a certain number of animals, of a great number of them, of a really surprising number of birds because of the incidence with which effectively birds intervene in inscriptions which need to be commemorated, of a plentiful number no doubt of instrumental

forms agrarian and others, of some signs also, which for all time, have been no doubt useful in their simplified form: the unary trait first of all, the bar, the cross of multiplication, which do not designate moreover the operations which were subsequently attached to these signs, but after all on the whole, it is quite evident at first glance that the baggage of drawings that we are dealing with has no proportion, congruence, with the effective diversity of objects which could be validly evoked in lasting inscriptions.

Moreover what you see, what I am trying to designate for you and (7) what is important to designate in passing to dissipate confusions for those who have not the time to go and look more



closely at things, is for example, the figure of a horned owl, to take a form of night bird particularly well drawn, locatable in the classic inscriptions on stone, we see it coming back extremely often, and why? It is certainly not the case that this animal itself is ever involved; the fact is that the common name of this animal in antique

Egyptian language can act as a support for the labial utterance *m* and that every time you see this animal figure, it is a matter of an *m*, and nothing else, which *m* moreover far from being represented simply in its literal value, every time you encounter this figure of the aforesaid horned owl, is susceptible to something which is made more or less like this (see the figure above).

The *m* will signify more than one thing, and in particular what we cannot, any more in this letter than in the Hebrew tongue when we have not the adjunction of vowel points, when we are not very fixed as regards the vocalic supports, we will not know exactly how this *m* is completed, but in any case we know enough broadly speaking from what we can reconstruct of the syntax to know that this *m* can moreover represent a certain function, which is more or less an introductory function of the type: "Look!"¹¹, a function for fixing the attention, as one might say, a voici: or again in (8) other cases where very probably it must be distinguished by its vocalic support, representing one of the forces, not of negation, but of something which must be specified as a stronger accent of the negative verb, of something which isolates negation in a verbal form, in a conjugatable form, in a form not simply of ne, but of something of which it is said that it is not. In short, it is a particular tense of a verb which we know which is certainly negative, or even more exactly a particular form in two negative verbs: the verb immi on the one hand, which seems to mean not to be and the verb gehom on the other hand which would seem to indicate more especially effective non-existence.

This is to tell you in this connection, and introducing in this connection in an anticipatory fashion the function that it is not by chance that what we find ourselves confronted with as we go along this path, is the relationship which is here incarnated, immediately manifested of the most primitive coalescence of the signifier with something which immediately poses the question of

what is negation, of what it is closest to. Is negation simply a connotation which then nevertheless is proposed as the question of the moment when with respect to the existence, to the exercise, to the constitution of a signifying chain there is introduced a sort of additional index, a siglum of virtual words as it is put, which ought therefore always to be conceived of as a sort of secondary invention required by the necessities of the utilisation of something which is situated at different levels: at the level of the response, what is put in question by the signifying interrogation, it is not there (cela n'y est pas); is it at the level of the response that this "is it not" (n'est-ce) (9) seems indeed to be manifested in language as the possibility of the pure utterance of the negation no, is it on the other hand in the mark of relationships that negation is imposed, is suggested by the necessity of disjunction: such a thing is not if another one is, one cannot be with the other? In short, the instrument of negation - we know it certainly, no less than the others - but then as regards the genesis of language, one is reduced to making of the signifier something which ought to be more or less elaborated starting from signs of emotion: the problem of negation is something which is posed as one properly speaking of a jump, indeed of an impasse.

If, in making a signifier, something quite different, something whose genesis is problematic, carries us to a level of interrogation about a certain existential relationship, the one which as such is already situated in a negativity-reference, the mode in which negation appears, in which the signifier of an effective negativity is experienced, can emerge, is something which takes on a quite different interest, and which is not then by chance, without being of a nature to illuminate us when we see that from its first problematics the structuring of language is identified, as one might say, by the location of the first conjugation of a vocal utterance with a sign as such, namely with something which already is referred to a first manipulation of the object; we had called it simplificatory when it was a matter of defining the genesis of the trait what is more destroyed, more effaced than an object. If it is from the object (10) that the trait emerges, it is something of the object that the trait retains: precisely its unicity. The effacing, the absolute destruction of all the other emergences, of all these other prolongations, of all these other appendices, of all the other ramified palpitating things there may be, well, this relationship of the object to the birth of something which is here called the sign, in so far as it interests us in the birth of the signifier, this indeed is what we have dwelt on and about which it is not unpromising for us to have made, as one might say, a discovery, because I believe that it is one. This indication that there is, let us say, at a time, a locatable time, one historically defined, a moment at which something is there to be read, read with language when there is still no writing, it is by the reversal of this relationship, and this relationship of reading to the sign, that writing can subsequently be born in so far as it can serve to connote phonemat icisation.

But it appears at this level, that precisely the proper name in so far as it specifies as such the rooting of the subject, is more specially linked than any other, not to the phonematisation as such, to the structure of the language, but to what already in the language is ready, as one might say, to receive this informing by the trait. If the proper name still carries even for us and in our usage, the trace under this form that it is not translated from one language to another, because it is simply transformed, it is transferred, and this indeed is its characteristic: I am called Lacan in every tongue, and you also, everyone by your name. This is not a contingent fact, a (11) fact of limitation, of impotence, a senseless fact, because on the contrary, it is here that there lies, that there resides the very particular property of the proper name in signification.

Is this not designed to make us question ourselves about what is at stake at this radical, archaic point that we must necessarily suppose to be at the origin of the unconscious, namely of this thing through which, in so far as the subject speaks, all he can do is to advance further along the chain, in the unfolding of enunciations, but that, directing himself towards the enunciations, by this very fact in the enunciating, he elides something which is properly speaking what he cannot know, namely the name of what he is qua enunciating subject.

In the act of enunciating, there is this latent nomination which can be conceived of as the primary kernel as signifier of what is subsequently going to be organised as a turning chain, such as I have always represented it for you from this centre, this speaking heart of the subject which we call "the unconscious".

Here, before we advance any further, I think I should indicate something which is only the convergence, the point of a thematic which we have tackled already on several occasions in this seminar, on several occasions by taking it up at the different levels at which Freud was led to approach, to represent, to represent the system, the first psychical system as it was necessary for him to represent it in some way to give a sense of what was in question: the system which is articulated as (12) unconscious, preconscious, conscious.

On several occasions, I had to describe on this blackboard, in differently elaborated forms, the paradoxes with which the formulations of Freud, at the level of the Entwurf, for example, confront us.

Today, I will limit myself to a topologisation as simple as the one that he gives at the end of the Traumdeutung, namely that of the layers across which there can occur breakthroughs, thresholds, eruptions from one level into another, such as the one which interests us to the highest degree: the passage from the unconscious into the preconscious for example, which is in effect a problem, which is a problem moreover - I note it with satisfaction in passing, it is certainly not the least effect that I might expect from the effort of rigour into which I am drawing you, that I am imposing on myself for you here, that

those who listen to me, who understand me, should raise themselves to a degree that is liable even on occasion to go further - well then, in their very remarkable text published in Les Temps Modernes on the subject of the unconscious, Laplanche and Leclaire - I am not distinguishing for the moment the share each of them has in this work - question themselves about what ambiguity remains in the Freudian enunciating concerning what happens when we can speak about the passage of something which was in the unconscious and passes into the preconscious. Does that mean that it is only a matter of a change of cathexis, as (13) they pose very correctly the question, or indeed is there a double inscription? The authors do not conceal their preference for the double inscription, they indicate it to us in their text.

This however is a problem that the text leaves open, and which after all what we are dealing with, will allow us this year, to contribute perhaps some responses to or at the very least some precise details.

I would like, in an introductory fashion, to suggest the following to you: it is that if we ought to consider that the unconscious is the locus of the subject where it speaks (ca parle) we come now to approach this point where we can say that something, without the subject knowing it, is profoundly altered by the retroactive effects of the signifier implied in the word. It is in so far as and for the least of his words, the subject speaks, that he cannot avoid always, once more, naming himself without knowing it, without knowing with what name. Can we not see that, in order to situate the relationships between the unconscious and the preconscious, the border for us is not to be situated first of all somewhere inside, as they say, a subject who is simply supposed to be simply the equivalent of what is called in the broad sense, the psychical?

The subject that we are dealing with, and especially if we try to articulate it as the unconscious subject, requires a different way of establishing of the frontier. What the preconscious is in so far as what interests us in the preconscious is language, the language here that effectively we not alone see, hear being (14) spoken, but that punctuates, articulates our thoughts. Everyone knows that the thoughts involved at the level of the unconscious, even if I say that they are of course structured like a language, it is in so far as they are structured in the final analysis and at a certain level like a language that they interest us, but the first thing to be recognised, is that it is not easy to express those we are speaking about in common language. What is involved, is to see that the articulated language of common discourse, with respect to the subject of the unconscious in so far as it interests us, is outside, an "outside" which connects to it what we call our intimate thoughts, and this language which flows to the outside not in an immaterial fashion, because we know well, because all sorts of things are there to represent it to us, we know what perhaps was not known by cultures where everything happened in the breath of the word, we who have before us kilos of language, and who know, what is more, how to inscribe the most fleeting word on discs.

We know well that what is spoken, the effective discourse, the preconscious discourse is entirely homogenisable as something which takes place outside: language as a substance is everywhere and here, there is effectively an inscription on a magnetic tape if necessary. The problem of what happens when the unconscious comes to make itself heard is where we see the problem of the border between this unconscious and this preconscious.

How should this border be seen?

It is the problem that, for the moment, I am going to leave open, but what we can, on this occasion, indicate, is that in passing from the unconscious into the preconscious, what is constituted (15) in the unconscious encounters an already existing discourse, as one might say, an interplay of liberated signs, not only interfering with the things of the real, but one might say closely woven like a mycelium into their gaps. Moreover, is this not the true reason for what one could call the idealist fascination, entanglement.

In philosophical experience, if man perceives or believes he perceives that he never has anything but ideas of things, namely, that in the final analysis he only knows ideas of things, it is precisely because already in the world of things, this parcelling into a universe of discourse, is something which can absolutely not be disentangled. The preconscious, in a word, is already in the real, and if the status of the unconscious for its part poses a problem, it is in so far as it is constituted at a completely different level, at a more radical level of the emergence of the act of enunciating. In principle there is no objection to the passage of something from the unconscious into the preconscious, what tends to manifest itself, the contradictory character of which Laplanche and Lecaire note so well. The unconscious has as such its status as something which by position and by structure is not able to penetrate to the level where it is susceptible to a preconscious reorganisation, and nevertheless, we are told, this unconscious, at every moment, makes the effort, pushes in the direction of making itself recognised; undoubtedly, and with good reason, it is because it is at home as one might say in a universe structured by discourse.

Here, the passage from the unconscious towards the preconscious is only, one might say, a sort of normal irradiation effect of (16) what is turning around in the constitution of the unconscious as such, of what maintains present in the unconscious the primary and radical functioning of the articulation of the subject qua speaking subject.

What must be seen, is that the order which is supposed to be that of the unconscious, the preconscious, arriving then at the conscious, is not to be accepted without being revised, and one can say that in a certain fashion, in so far as we must admit what is preconscious as defined, as being in the circulation of the world, in the real circulation, we must conceive that what happens at the level of the preconscious is something which we have to read in the same fashion, in the same structure, as the

one I tried to get you to sense at this root-point where something comes to contribute to language what one could call its final sanction: this reading of signs, at the actual level of the life of the constituted subject, of a subject elaborated through a long history of culture, what happens, is that for the subject a reading outside of what is all-encompassing because of the presence of language in the real and at the level of the conscious, that level which, for Freud, always seemed to be a problem he never stopped indicating that it was certainly the object of future specification, of more precise articulation as regards its economic function at the level that he describes it for us at the beginning, at the moment when he is separating out his thought let us remember how he describes for us this protective layer that he designates by the term CO, it is above all something which, for him, is to be compared with the surface film of sensory organs, namely essentially with something which (17) filters, which blocks out, which only retains this index of quality whose function we can show is homologous with this index of reality which just allows us to appreciate the state that we are in, enough to be sure that we are not dreaming, if it is a matter of something analogous, it is really what is visible that we are seeing. In the same way, consciousness, compared to what constitutes preconsciousness and constructs for us this world closely woven by our thoughts, consciousness is the surface through which this something which is the heart of the subject, receives, as one might say, from the outside his own thoughts, his own discourse.



Consciousness is there in order that the unconscious, as one might say, may much rather refuse what comes to it from the preconscious or choose in it in the most precise fashion what it needs for its own purposes; and what is that?

It is indeed there that we encounter this paradox which is the one that I called the intersection of systemic functions at this first level so essential to recognise in Freud's articulation: the unconscious is represented for you by him as a flux, as a world, as a chain of thoughts. No doubt consciousness also is made up of the consistency of perceptions. Reality testing is the articulation of perceptions between themselves in a world.

Inversely, what we find in the unconscious, is this significant repetition which leads us from something which are called thoughts, Gedanken, which are very well formed, Freud says, to a (18) concatenation of thoughts, which escapes from us.

Now, what is Freud himself going to tell us? That what the subject seeks at the level of both one and the other of these systems, that at the level of the preconscious, what we seek is properly speaking the thought-identity, this was what was elaborated by this whole chapter of philosophy; the effort of our organisation of the world, the logical effort, is properly speaking to reduce the different to the identical, it is to identify thought to thought, proposition to proposition in differently articulated relationships which form the very texture

of what is called formal logic, which poses for someone who considers in an extremely ideal fashion the edifice of science as being able to be or as having even virtually been already achieved, which poses the problem of knowing whether effectively, every science of knowledge, every grasp of the world in an ordered and articulated way must not end up in tautology.

It is not for nothing that you have heard me on several occasions evoke the problem of tautology and there is no way that we will be able to terminate our discourse this year without forming a definitive judgement on it.

The world therefore, this world whose reality-function is linked to the perceptual-function is all the same that about which we make no progress in our knowledge except by way of thought identity. This is in no way a paradox for us, but what is paradoxical, is to read in the text of Freud that what the unconscious seeks, what it wants, as one might say, what is the (19) root of its functioning, of its being brought into play, is perceptual-identity, namely that this would have literally no meaning if what was involved, was only the following: that the relationship of the unconscious to what it seeks in its own mode of return, is precisely what in the once perceived is identically identical, as one might say, is what was perceived at that time, is this ring that he put on his finger with the stamp of that time, and it is precisely this that will always be lacking: the fact is that in every other kind of reappearance of what corresponds to the original signifier, at the point where there is the mark that the subject has received from anything whatsoever at the origin of the Urverdrangt, there will always be lacking in anything whatsoever that comes to represent it, this mark which is the unique mark of the original appearance of an original signifier which once presented itself at the moment when the point, the something of the Urverdrangt in question passed to an unconscious existence, to the insistence in this internal order which the unconscious is, between, on the one hand what it receives from the outside world and where there are things to be bound: from the fact that by binding them in a signifying form, it can only receive them in their difference, and this indeed is the reason why he cannot in any way be satisfied by this seeking of perceptual-identity as such if it itself is what specifies it as unconscious.

This gives us the triad: conscious, unconscious, preconscious, in a slightly modified order and in a certain fashion, which justifies the formula which I already tried to give you once of the unconscious, in telling you that it was between perception and consciousness, as one says between the skin and the flesh (entre cuir et chair). This indeed is something which, once we (20) have posed it indicates that we should refer ourselves to this point from which I started in formulating things beginning with the philosophical experience of the subject's search, as it exists in Descartes in so far as it is strictly different from anything that was able to be done at any other moment of philosophical reflection, in so far as it is indeed the subject who is himself questioned, who tries as such to be so: the

subject in so far as he goes at it in very truth, that what is questioned here, is not the real and the apparent, the relationship between what exists and what does not exist, of what remains and what disappears, but to know whether one can trust the Other, whether as such what the subject receives from outside is a reliable sign. The "I think, therefore I am" which I sufficiently triturated before you for you to be able to see now more or less how the problem of it is posed. This "I think" about which we have said that it is properly speaking meaningless - and this is what gives it its value - it has not, of course, any more meaning than the "I lie", but he can do nothing starting from its articulation but realize himself that "therefore I am" is not the consequence that he draws from it, but the fact is that he cannot help thinking from the moment when truly he begins to think, namely that it is in so far as this impossible "I think" changes to something which is of the order of the preconscious that it implies as signified, and not as consequence, as ontological determination, that it implies as signified that "I think" refers back to an "I am" which henceforth is no more than the x of this subject which we are seeking, namely of what there is at the beginning in order that there should be produced the identification of this "I think". (21) Notice that this continues. An so on. If "I think that I think that I am" - I am no longer being ironical: if "I think that I can do no other than be a pense-a-e'tre or a thinking being: the "I think" which is here the denominator sees very easily being produced the same duplicity, namely that I can do nothing other than to perceive that thinking that I think, this "I think" which is at the end of my thinking, over my thinking, is itself an "I think" which reproduces the "I think, therefore I am". Does this go on ad infinitum?

Certainly not: it is also one of the most usual modes of philosophical exercise when people began to establish such a formula to apply that what one was able to retain from it in terms of effective experience is in a way indefinitely multipliable like in a game of mirrors.

I think

I am

I am - I think

I am - I think

I am - I think.

There is a little exercise which is the one that I devoted myself to at one time - my little personal sophism - that of the assertion of anticipated certainty in connection with the game of disks where it is from noting what the two others do that a subject has to deduce the even or odd mark on his own back, namely something very close to what is involved here.

It is easy to see in the articulation of this game that far from the hesitation which it is, in effect, quite possible to see being produced, because if I see the others deciding too quickly about the same decision that I want to take, namely that I am like them marked with a disk of the same colour, if I see them

drawing their conclusions too quickly, I will draw from it precisely the conclusion, I can in this case see some hesitation arising for myself, namely that if they have seen so quickly who they were, it must be that I myself am distinct enough from them to locate myself, because if one is logical, they must be thinking the same thing: we see them oscillating also and saying to themselves: let's have a second look at it; namely that the three subjects we are dealing with will have the same hesitation together, and one can easily show that it is effectively only after three hesitating oscillations that they can really have and will certainly have and in a way fully, figured out through the scansion of their hesitation, the limitations of all the contradictory possibilities.

There is something analogous here: one cannot indefinitely include all the "I think, therefore I am"'s in an "I think"; where is the limit? This is what we cannot immediately say and know so easily here. But the question that I am posing, or more exactly the one that I am asking you to follow, because, of course, you are perhaps going to be surprised, but it is subsequently that you are going to see coming here being joined on what can modify, I mean subsequently render operational, what seemed to me at first sight only a sort of game, even what is called a mathematical recreation.

(23) If we see that something in the Cartesian understanding, which certainly terminates in its enunciating at different levels, because moreover there is something which cannot go any further than what is inscribed here, and it is necessary that he should make intervene something which comes, not from the pure elaboration, "on what can I base myself?". What is viable? He is indeed going to be led like everybody else to try to manage with what is experienced but in the identification which is the one which is made to the unary trait, is there not enough to support this unthinkable and impossible point of the "I think" at least under the form of its radical difference?

If it is through one that we depict it, this "I think" I repeat in so far as it only interests us in the measure that it is related to what is happening at the origin of nomination in so far as it is what concerns the birth of the subject, the subject is what names itself. If naming is first of all something which has to deal with a reading of the trait one designating absolute difference, we can ask ourselves how I might depict the sort of "I think" which here is constituted in a way retroactively simply by the reprojection of what is constituted as the signified of the "I think", namely the same thing, the unknown of what is at the origin under the form of the subject. If the 1 that I am indicating here in the definitive form that I am going to leave to it is something which, here, is supposed in a total problematic, namely that it is just as much true as it is not because it is only thinking about thinking, is nevertheless

$$1 - \frac{1}{1-1} \\ \frac{1}{1-1} \\ \frac{1}{1-1}$$

(24) correlative, indispensable, and this is what gives its force to the Cartesian argument about every apprehension of a thought once it is linked up - the path is

opened to him towards a cogitatum of something which is articulated as "cogito ergo sum".

I will skip over for you today the intermediary steps because you will see subsequently where they come from, and because after all, at the point that I have got to, I had to pass through them. There is something which I will say is at once paradoxical - why not say amusing - but I will repeat it for you: if this has an interest, it is in so far as it is operational: a formula like this in mathematics, is what is called a series (see the schema): I will pass over here something which may immediately, for anyone who is used to mathematics, be posed as a question: if it is a series, is it a convergent series? What does that mean? That means that if instead of having i you had 1 's everywhere, an effort at putting it into form would allow you immediately to see that this series is convergent namely if I remember rightly, it is equal to something like:

$$\frac{-1 + \sqrt{5}}{2}$$

The important thing, is operations in question: that this means that if you carry out the

$$\begin{aligned} 1 + 1 &= 2 \\ 1 + \frac{1}{2} &= 1\frac{1}{2} \\ &= \frac{5}{3} \end{aligned} \quad \text{etc.....}$$

(25) you have therefore the values which, if you carry them forward, will take more or less this form here until they come to converge on a perfectly constant value which is called a limit:

$$\frac{i + \frac{1}{i + \frac{1}{i + \frac{1}{i + \frac{1}{i + \frac{1}{\dots}}}}}}{i + \frac{1}{i + \frac{1}{i + \frac{1}{i + \frac{1}{\dots}}}}}$$

Finding a convergent formula in the preceding formula would be all the less interesting for us in so far as the subject is a function which tends towards a perfect stability, but what is interesting - and this is where I am skipping something, because - to make my position clear - I do not see any other way except that of beginning to project the task and come back afterwards to clarify things - take i , trusting me for the value that it has exactly in the theory of numbers where it is called imaginary - this is not a homonymy which, simply by itself, appears to me to justify here this methodical extrapolation, this little moment of a leap and of trust which I am asking you to make - this imaginary value is the following: $\sqrt{-1}$ You know enough elementary arithmetic all the same to know that the square root of minus 1 is not any real number: there is no negative number for example which could in any way, fulfill the function of being the root of some number or other of which the root of minus one would be the factor.

Why?

Because in order to be the square root of a negative number, that means that raised to the power of two, that would give a negative number. Now, no number, raised to the power of two, can give a negative number, because every negative number that is raised to

the power of two becomes positive. This is why the root of minus 1 is nothing but algorithm, but it comes in handy.

(26) If you define as a complex number any number composed of a real number to which there is joined an imaginary number, namely a number which cannot in any way be added to it, because it is not a real number, made up of the product of the root of minus 1 with b, if you define this complex number, you can perform with this complex number, and with the same success, all the operations that you can perform with real numbers and when you have started off on this path you will not only have the satisfaction of seeing that this works, but that it allows you to make discoveries, namely to see that numbers constituted in this way have a value which allows you specifically to operate in a purely numerical fashion with what are called vectors, namely with magnitudes which, for their part, will be not only provided with a value representable in a different way by a length but what is more, that thanks to the complex numbers you can implicate in your connotation, not alone the aforesaid magnitude, but its direction, and especially the angle that it makes with another magnitude, in such a way that $\sqrt{-1}$ which is not a real number, proves from the operational point of view to have a singularly more astounding power, as I might say, than anything that you had at your disposition up to then by limiting yourself to the series of real numbers.

This in order to introduce you to what this little i is. And then if one supposes that what we are trying to connote here in a numerical fashion is this conventional value: $\sqrt{-1}$ what does that mean? something we can operate on by giving it

(27) That just as we have applied ourselves to elaborating the function of unity as a function of the radical difference in the determination of this ideal centre of the subject which is called the ego-ideal, in the same way subsequently - and for a good reason, the fact is that we will identify it to what we have introduced up to now in the connotation which is personal to ourselves as namely the imaginary function of the phallus - we are going to occupy ourselves with extracting from this connotation, $\sqrt{-1}$, all the ways it can be of use to us in an operational fashion; but, meanwhile, the utility of its introduction at this level is illustrated by the following: it is that if you seek out what it does, this function of the root of minus one plus one over the root of minus one plus, other words, it is $\sqrt{-1}$ etc... in seen i, you which is there everywhere that you have convergent see appearing a function which is not at all a

$$\sqrt{-1} + \frac{1}{\sqrt{-1}} + \frac{1}{\sqrt{-1}+1}$$

function, which is a periodic function: which is easily calculable; it is a value which is renewed as one might say every third time in the series.

$$i+1$$

The series is defined as follows:

first term of the series

$$i + \frac{1}{i+1}$$

second term of the series and third term.

You rediscover periodically, namely every third time in the series this same value, the same three values which I am going to give you:

(20) 1 The first is, namely the enigma-point that we are at in order to ask ourselves what value we can indeed give to i in order to connote the subject qua subject before any nomination, a problem which interests us.

The second value you find, namely $i + \frac{1}{i+1}$ is strictly equal $\frac{i+1}{2}$ and this is rather interesting; because the first thing that we encounter is the following: it is that the essential relationship of this something that we are seeking as being the subject before it is named, to the use that he can make of his name quite simply as being the signifier of what there is to be signified, namely of the question of the signified precisely of this addition of himself to his own name, it is immediately to divide it in two. to bring it about that there remains only a half of literally of what there was present. As you can see, my words are not prepared, but they are all the same carefully calculated and these things are all the same the fruit of an elaboration which I have tried to find my way into in dozens of different ways while assuring myself of a certain number of controls, having subsequently a certain number of switching points in the times that are going to follow.

The third value, namely, when you stop the term of the series there will be quite simply 1, something which in several ways, can have for us the value of a sort of confirmation as a buckle, I mean that it is to know whether it is at the third moment, a curious thing, a moment towards which no philosophical meditation (29) has pushed us in any special way to dwell on, namely at the moment of the "I think" in so far as it is even an object of thinking and that it takes itself as an object, it is at that moment that we seem to manage to reach this famous unity whose satisfying character for defining anything whatsoever is assuredly in no doubt, but about which we can ask ourselves whether it is indeed the same unity that is involved as the one that was involved at the beginning, namely in the primordial initiating identification. In any case I have to leave this question open for today.

Seminar 8: Wednesday 17 January 1962

I do not think that however paradoxical the symbolisation on which I ended my discourse the last time may appear at first approach, making the subject be supported by the mathematical symbol of the root of -1 , I do not think that everything in this could have been only pure surprise for you. I mean that in recalling the Cartesian approach itself, one cannot forget what this approach leads its author to. Here he is setting off with a good stride towards the truth, and what is more: this truth is in no way, for him as for us, placed in the parenthesis of a dimension which distinguishes it from reality, this truth towards which Descartes advances with a conquering stride is indeed that of the thing, and this leads us to what? To emptying the world to the extent of no longer leaving anything of it except this void which is called extension. How is this possible?

As you know, he is going to choose as an example: melt a block of wax. Is it by chance that he chooses this material or is he drawn to it because it is the ideal material for receiving the divine seal, signature. Nevertheless, after this quasi-alchemical operation that he carries out before us, he is going to make it vanish, be reduced to being nothing more than pure extension, no longer anything on which an impression can be made. If precisely in his approach, there is no longer any relationship between the signifier and any natural trace, if I (2) can express myself in this way, and very specifically the natural trace par excellence which the imaginary of the body constitutes, this is not to say precisely that this imaginary can be radically rejected. But it is separated off from the operation of the signifier. It is what it is: an effect of the body, and as such impugned as witness to any truth; there is nothing to be done with it except to live with it, with this imaginary theory of the passions, but certainly not to think with it: man thinks with a discourse reduced to the facts of what one could call natural light, namely a logistical group which, consequently, could have been different if God had willed it (The theory of the passions).

What Descartes is still not able to see, is that we can will it in his place, it is that some 150 years after his death set theory was born - he would have loved it - in which even the figures one and zero are only the object of a literal definition, of a purely formal axiomatic definition, a neutral element. He could have done without the truthful God, the deceiving God not

being able to be other than the one who might cheat in the solution of the equations themselves. But nobody has ever seen that: there is no miracle in the combinatory, if not the meaning that we give it; every time we give it a meaning it is already suspect. That is why the Word exists, but not Descartes' God. For Descartes' God to exist, it would be necessary for us to have some beginnings of a proof of his own creative will in the domain of mathematics. But, it is not he who invented the transfinite, the quantum, it is we. This indeed is why history bears witness (3) to us that the great mathematicians who opened up this beyond of divine logic, Euler in the first place, were very frightened; they knew what they were doing, they encountered, not the empty extension of Descartes' approach, which finally, despite Pascal, no longer frightens anyone because people are encouraged more and more to go and live in it, but the void of the Other, a much more terrifying place because someone is necessary there. This is why, in circumscribing in the closest possible way the question of the meaning of the subject as it is evoked in Cartesian meditation, I think I am doing nothing more here - even if I am trespassing on a domain which has been gone over so often that it ends up by appearing to become reserved to particular people - I do not believe I am doing something which can fail to be of interest, this even in so far as the question is a current one, more current than any other, and still more current - I think I will be able to show it to you - in psychoanalysis than elsewhere.

What I am therefore going to lead you towards today, is a consideration, not about the origin, but about the position of the subject, in so far as at the root of the act of the word there is something, a moment at which he is inserted into the structure of language, and this structure of language, in so far as it is characterized at this original point, I am trying to circumscribe, to define, in terms of a thematic which, in a vivid way, is incarnated, is included in the idea of an original contemporaneity of writing and of language, and that writing is signifying connotation, that the word does not create it so much as bind it, that the genesis of the signifier at a certain level of the real which is one of its axes or roots, is no doubt for us the principle way of connoting the coming to light of effects, (4) called effects of meaning.

In this first relationship of the subject, in what he projects before him, nachträglich by the simple fact of engaging himself by his word, first of all in a stammering way, then in a playful, indeed confusing way in the common discourse, what he projects of his act backwards, there is produced this something which we have the courage to go towards in order to interrogate it in the name of the formula: "Wo Es war, soll Ich werden", which we would tend to push towards a very slightly differently accentuated formula in the sense of a being having been, of a Gewesen which subsists in as much as the subject advancing towards it cannot ignore that a work of profound reversing of his position is necessary for him to grasp himself there. Already there, something directs us towards something which is very controversial, suggests to us the remark that all by itself, in

its existence, negation has not failed always to conceal a question. What does it suppose? Does it suppose the affirmation on which it is based? No doubt. But is this affirmation for its part simply the affirmation of something of the real which has been simply removed? It is not without surprise, it is not either without malice that we can find from the pen of Bergson some lines in which he rises up against every idea of nothingness, a position quite in conformity with a thinking fundamentally attached to a sort of naive realism.

There is more, and not at all less, in the idea of an object conceived of as not existing, than in the idea of the same object conceived of as existing, because the idea of the object not (5) existing is necessarily the idea of the object existing with, in addition, the representation of an exclusion of this object by the present reality taken as a whole.

Can we be satisfied with situating it in this way? For a moment, let us direct our attention towards negation itself. This is the way in which we are going to be able to satisfy ourselves, to situate its effects in a simple experience of its use, of its employment.

To lead you to this place along all the paths of a linguistic enquiry is something that we cannot refuse ourselves. Besides, already, we have advanced along this direction, and if you remember, allusion has been made here for a long time to the certainly very suggestive, even illuminating, remarks of Pichon or of Damourette, in their collaboration on a grammar which is very rich and very fruitful to consider, a grammar especially of the French tongue in which their remarks come to highlight that there is not, they say, properly speaking any negation in French. What they mean is that what to their eyes is this simplified form of radical ablation, as it is expressed at the end of certain German sentences, I mean at the end because it is indeed the term nicht which by coming in a surprising fashion at the conclusion of a sentence carried on in a register that allowed the listener to remain up to its end in the most complete indétermination and fundamentally in a position of belief; by this nicht which erases it, the whole signification of the sentence finds itself excluded, excluded from what? From the field of the admissibility of the truth.

(6) Pichon remarks, not without relevance, that the most ordinary division, split, of negation in French between a ne on the one hand, and an auxiliary word, the pas, the personne, the rien, the point, the mie, the goutte, which occupy a position in the enunciative sentence which remains to be specified with respect to an ne named at first, that this suggests to you specifically, by looking closely at the separate usage that can be made of it, to attribute to one of these functions a signification called discordant, and to the other an exclusive signification.

It is precisely the exclusion from the real which would be the responsibility of the pas, the point, while the ne would express this dissonance sometimes so subtle that it is only a shadow, and

specifically in this famous ne of which you know that I made a great fuss in order for the first time precisely to show in it something like the trace of the subject of the unconscious, this ne which is called expletive. The ne of this "je crains qu'il ne vienne" (I am afraid that he will come) you immediately put your finger on the fact that it means nothing other than "I was hoping that he would come", it expresses the discordance of your own feelings with respect to this person, that it carries in a way its trace which is all the more suggestive because it is incarnated in its signifier because in psychoanalysis we call it ambivalence: "je crains qu'il ne vienne", does not express so much the ambiguity of our feelings as by this overloading show how much, in certain types of relationships, there is able to arise, to emerge, to be reproduced, to be marked in a gap, this distinction between the subject of the act of enunciating as such, with respect to the subject of the enunciation, even if he is not present at the level of the enunciation in a fashion which (10) designates him. "Je crains qu'il ne vienne" is a third; it would be if what was said was "je crains que je ne fasse" (I am afraid that I will make) - which is hardly ever said, even though it is conceivable - which would be at the level of the enunciation; nevertheless, it is of little importance that he can be designated - you see moreover that I can bring him into it - at the level of the enunciation; and a subject, masked or not at the level of enunciating, represented or not, leads us to pose the question of the function of the subject, of its form, of what it supports, and not to deceive ourselves, not to believe that it is simply the I which, in the formulation of the enunciation, designates him as the one who in the instant which defines the present, carries the word. The enunciating subject has perhaps always another support. What I articulated, is that, much more, this little ne, graspable here in its expletive form, is where we should recognise the support properly speaking in an exemplary case, and moreover this is not to say of course, that we should recognise its exclusive support in this exceptional phenomenon.

Usage of the tongue is going to allow me to accentuate before you in a very banal fashion, not so much Pichon's distinction - in fact, I do not believe it is sustainable up to its descriptive term; phenomenologically it reposes on the idea, inadmissible for us, that one can in some way fragment the movements of thinking. Nevertheless, you have this linguistic consciousness which allows you to appreciate immediately the originality of the case where you have simply, or you can in the present usage of the tongue - it was not always this way: in archaic times the form that I am (8) now going to formulate before you was the more common one; in every tongue an evolution is marked by a sliding of the forms of negation that linguists try to characterise. The direction in which this sliding takes place - later I will perhaps give its general line, it is expressed in what the specialists write, but for the moment let us take the simple example of what is quite simply available to us all - in the distinction between two equally admissible, equally acceptable, equally expressive, equally common formulae: that of "je ne sais" (I do not know) and "j'sais pas" (don't know). You see, I think immediately what the difference between them is, the difference of accent. This "je

ne sais" is not without some mannerism, it is literary, it is better all the same than "jeunes nations" (young nations) but it is of the same order. They are both Marivaux, if not rivals (rivaux).

What this je ne sais expresses is essentially something quite different to the other code of expression to the one of j'sais pas: it expresses oscillation, hesitation, even doubt. If I evoked Marivaux, it is not for nothing: it is the ordinary form in which veiled avowals can be made on the stage. As regards this "je ne sais", one would have to amuse oneself by writing, (9) with the ambiguity given by my play on words, the j'sais pas by the assimilation that it undergoes because of the nearness of the inaugural s of the verb, the j of je which becomes the aspirative che which becomes by this the silent sibilant. The ne which is swallowed here disappears: the whole sentence comes to repose on the heavy pas of the occlusive which determines it. The expression would only take on its slightly derisory, even folksy accentuation in this case precisely from its discourse and what was being expressed at the time. The "j¹sais pas" marks, as I might say, even the impact of something in which on the contrary the subject has collapsed or is grovelling. "How did you manage that", authority demands of the person responsible, after some unfortunate misadventure: "j'sais pas". It is a hole, a gap which opens up at the bottom of which what disappears, is engulfed, is the subject himself, but here he no longer appears in his oscillatory movement, in the support which is given to him in his original movement, but on the contrary, in the form of a recognition of his ignorance properly speaking expressed, assumed, rather projected, affirmed, it is something which presents itself as a not being there, projected onto a surface, onto a plane where it is as such recognisable.

And what we approach along this path in these remarks which are verifiable in a thousand ways, by all sorts of other examples, is something the idea of whose double aspect we should at the very least retain. Is this double aspect really one of opposition, as Pichon seems to suggest - as regards the apparatus itself, would (10) a more serious examination allow us to resolve it?

Let us remark first of all that the ne of these two terms seems to undergo the attraction of what one could call the leading group of the sentence, in so far as it is grasped, supported by the pronominal form: this leading group in French is remarkable in the formulae which gather it together such as "je ne le" and "je le lui", this grouped before the verb certainly does not fail to suggest a profound structural necessity: that the ne should come to aggregate itself to it, is not I would say what appears most remarkable to us. What appears most remarkable to us is the following: it is that by coming to aggregate itself to it, it accentuates what I would call its subjective signification.

Notice in effect, that it is not by chance that it is at the level of a "je ne sais", of a "je ne puis", of a certain category which is that of verbs that there is situated, inscribed the subjective position itself as such, that I found my example of

the isolated use of the *ne*. There is in effect a whole register of verbs whose usage is liable to make us remark that their function changes profoundly by being employed in the first or the second or the third person. If I say "je crois qu'il va pleuvoir" (I think it is going to rain) this is not distinguished from my enunciating that it is going to rain, an act of belief; I believe it is going to rain simply connotes the contingent character of my forecast. Observe that things are modified if I pass onto other persons: "tu crois qu'il va pleuvoir" (you think it is going to rain) makes much more of an appeal to something: the one to whom I am addressing myself, I am appealing to his testimony. "Il croit qu'il va pleuvoir" (he thinks it is going (11) to rain) gives more and more weight to the subject's adherence to his belief. The introduction of the *ne* will always be easy when it comes to join itself to these three pronominal supports of this verb which has here a varied function: from the beginning of the enunciative nuance up to the enunciation of a position of the subject; the weight of the *ne* will always be to bring it back towards the enunciative nuance.

"Je ne crois pas qu'il va pleuvoir", is even more linked to the character of dispositional suggestion which is mine. This may have absolutely nothing to do with a non-belief, but simply with my good mood. "I do not think that it is going to rain", "I do not think that it should rain", means that to me things do not appear to present themselves too badly.

In the same way, by joining it to two other formulations, which moreover is going to distinguish two other persons, the *ne* will tend to je-iser what is involved in the other formulae. "You do not think that it is going to rain", "he does not think that it should rain". It is indeed in so far as, it is indeed towards the *je* that they will be drawn because of the fact that it is with the addition of this little negative particle that they are here introduced into the first member of the sentence.

Does this mean that over against this we should make of the pas something which, quite brutally, connotes the pure and simple fact of privation? This would certainly be the tendency of Pichon's analysis, in so far as he finds in effect that grouping the examples gives every appearance of it. In fact, I do not (12) think so for reasons which belong first of all to the very origin of the signifier we are dealing with. No doubt, we have the historical genesis of their form of introduction into usage. Originally, "je n'y vais pas" (I am not going there) can be accentuated by a, "je n'y vais pas pas" (I am not going there at all), as I might say; "je n'y vois point" (I do not see at all): not even with a point; "je n'y trouve goutte" (I do not find anything in it), "il n'en reste mie" (nothing at all of it remains), it is indeed a matter of something which, far from being at its origin the connotation of the hole of absence well expresses on the contrary reduction, disappearance no doubt, but not completed, leaving behind it the furrow of the tiniest, the most fleeting trait.

In fact these words, easy to restore to their positive value, to

the point that they are currently employed with this value, receive indeed their negative charge from the sliding which is produced towards them of the function of the ne, and even if the ne is elided, it is indeed a matter of its charge on them in the function that it exercises. Something as one might say, of the reciprocity, let us say, of this pas and of this ne will be brought home to us by what happens when we invert their order in the enunciation of the sentence.

We say - an example from logic - "pas un homme qui ne mente" (there is no man who does not lie) in this case it is indeed the pas which opens fire. What I intend to designate here, make you grasp, is that the pas even though it opens the sentence in no way plays the same function which would be attributable to it, according to Pichon, if this were what is expressed in the following formulae: I arrive and I note: "il n'y a ici pas un chat" (there isn't a cat here). Between ourselves, allow me to point out to you in passing the illuminating, privileged, even (13) redoubling value of the very usage of such a word: not a cat. If we had to draw up the catalogue of the means of expressing negation, I would propose that we should put under this heading these type of words which become a support for negation, they do not at all fail to constitute a special category. What does a cat have to do with the question? But let us leave that for the moment.

"Pas un homme qui ne mente" shows its difference from this concert of lack, something which is at an altogether different level and which is sufficiently indicated by the usage of the subjunctive.

The "pas un homme qui ne mente" is at the same level as what motivates, what defines all the most discordant forms, to use Pichon's term, that we could attribute to the ne from the "je crains qu'il ne vienne" to the "avant qu'il ne vienne" (before he comes), to the "plus petit que je ne le croyais" (smaller than I thought he was) or again, "il y a longtemps que je ne l'ai vu" (it is a long time since I have seen him), which pose - I am saying it to you in passing - all sorts of questions which I am, for the moment, forced to leave to one side. I point out to you in passing what supports a formula like "it is a long time since I have seen him", you cannot say it in connection with someone who is dead nor with someone who has gone missing; "it is a long time since I have seen him" supposes that the next encounter is always possible.

You see the prudence with which the examination, the investigation of these terms ought to be handled and this is why, (14) at the moment of trying to expose, not the dichotomy, a general table of the different levels of negation, in which our experience brings us matrice entries which are much richer than anything that was done at the level of philosophers from Aristotle to Kant, and you know what they are called, these matrice entries: privation, frustration, castration, it is these that we are going to try to take up again in order to confront them with the signifying support of negation as we can try to

identify it.

"There is no man who does not lie", what does it suggest to us this formula, "homo mendax", this judgement, this proposition which I present to you under the typical form of universal affirmation, to which you know perhaps I already made an allusion in my first seminar of this year, in connection with the classical usage of the syllogism "all men are mortal", Socrates etc... with what I connoted in passing about its transferential function.

I believe that we can get something to approach this function of negation at the level of its original, radical usage by the consideration of the formal system of propositions as Aristotle classified them in the categories described as universal affirmative and negative and also of the particular also called negative and affirmative: AEIO.

Let us say it right away: this subject described as the opposition of propositions, the origin in Aristotle of his whole (15) analysis, of the whole mechanism of the syllogism, does not fail despite appearances to present the most numerous difficulties: to say that the developments of the most modern logistics have clarified these difficulties would certainly be to say something which the whole of history is against. On the contrary, the only thing that it can make seem astonishing, is the appearance of uniformity in the approval that these so-called Aristotelian formulae encountered up to Kant, because Kant preserved the illusion that this was an unattackable edifice.

Undoubtedly, it is not nothing to be able for example, to point out that the accentuation of their affirmative and negative function is not articulated as such in Aristotle himself and that it is much later, with Averroes probably, that their origin should be put. This is to show you moreover that things are not so simple when you try to form a judgement on them. For those who need to be reminded of the function of these propositions, I am going to recall them briefly.

"Homo mendax", since it is what I have chosen to introduce this reminder. Let us take it then: homo, and even omnis homo: "Omnis homo mendax" = every man is a liar. What is the negative formula? According to a form which is valid in many tongues: "omnis homo non mendax" may be enough. I mean that "omnis homo non mendax" means that as regards every man, it is true that he is not a liar. Nevertheless, for clarity, it is the term nullus (16) that we use: "nullus homo non mendax".

A : omnis homo mendax
universal
affirmative

E : nullus homo non mendax
universal
negative.

Here is what is usually connoted by the letters A and E respectively of the universal affirmative and the universal negative.

What is going to happen at the level of particular affirmatives?

Because we are interested in the negative, it is in a negative form that we are going to be able to introduce them here: "non omnis homo mendax" not every man is a liar, in other words, I choose and I note that there are men who are not liars.

In short, this does not mean that someone, aliquis, may not be a liar, aliquis homo mendax. This is the particular affirmative habitually designated in the classical notation by the letter I.

Here, the particular negative will be the "non omnis" being here resumed by "nullus",: "non nullus homo non mendax" = there is no man who is not a liar. In other words, in the whole measure that we have chosen to say that not all men were not liars (first case), this expresses in another fashion, namely that there is no (17) one who is a non-liar.

The terms organised in this way are distinguished in the classical theory by the following formulae, which put them reciprocally in what is called the position of control or of sub-control, namely that the universal propositions are opposed at their own level as not being allowed to be and not being able to be true at the same time. It cannot at the same time be true that every man can be a liar and that no man can be a liar, while all the other combinations are possible.

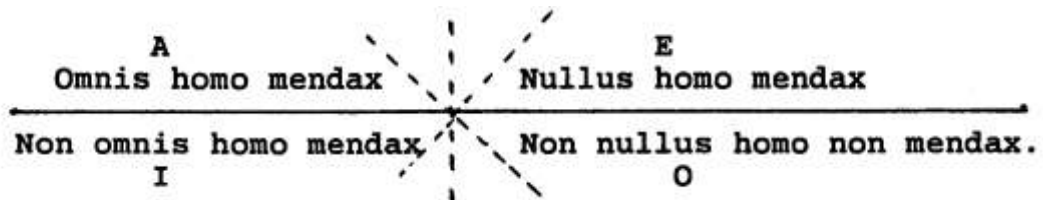

It cannot at the same time be false that there are men who are liars and men who are not liars.

The so-called contradictory opposition is that through which the propositions situated in each one of these quadrants are diagonally opposed in the fact that each one excludes, if it is true, the truth of the one which is opposed to it as contradictory, and being false excludes the falseness of the one which is opposed to it as contradictory.

If there are men who are liars, this is not compatible with the fact that no man is a liar. Inversely, the relationship is the same between the negative particular and the universal (18) affirmative.

What am I going to propose to you in order to make you sense what, at the level of the Aristotelian text, always presents itself as what has developed in history in terms of confusion

around the definition of the universal as such?

Observe first of all that if here I have introduced for you the non omnis homo mendax: the not all, the term not being brought to bear on the notion of the all as defining the particular, this is not because this is legitimate, because precisely Aristotle opposes it in a fashion which is contrary to all the development that was subsequently made by speculation about formal logic, namely a development, an explanation in extension making the symbolisable framework intervene by a circle, by a zone within which the objects constituting its support are assembled: Aristotle, very precisely, before the Prior Analytics, at least in the work which preceded it in the grouping of his works, but which apparently antecedes it logically, if not chronologically, which is called De interpretatione, remarks - and not without having provoked the astonishment of historians - that it is not on the qualification of universality that negation should be brought to bear. It is therefore indeed some man or other that is in question and some man or other that we ought to interrogate as such, as a liar.

The qualification therefore of omnis, of allness, of the parity of the universal category is here what is in question. Is it something that is at the same level, at the same level of existence as what can support, or not support the affirmation or (19) the negation, is there a homogeneity between the two levels? In other words, is it something that simply supposes as realised the collection involved in the difference between the universal and the particular?

Overturning the import of what I am in the process of trying to explain to you, I am going to propose something to you, something which is designed in a way to respond to what? To the question which precisely links the definition of the subject as such to that of the order of affirmation or of negation in which it enters in the operation of this propositional division.

In the classical teaching of formal logic, it is said - and if you investigate what that goes back to, I am going to tell you, it is not without a certain piquancy - it is said that the subject is taken from the angle of quality and that the attribute that you see here incarnated by the term mendax is taken from the angle of quantity. In other words, in the one, they are all, they are several, indeed there is one of them. This is what Kant still preserves at the level of The Critique of Pure Reason in the third division. This does not fail to give rise to considerable objections on the part of linguists.

When one looks at things historically, one perceives that this quality/quantity distinction has an origin: it appears for the first time paradoxically in a little treatise about the doctrines of Plato, and this - it is on the contrary the Aristotelian enunciation of formal logic which is reproduced, in an (20) abbreviated fashion but not without a didactic emphasis, and the author is none other than Apuleius, the author of a treatise on Plato - is found to have here a singular historical function,

it is namely to have introduced a categorisation, that of quantity and of quality, of which the least one can say is that it was because it had been introduced and had remained for such a long time in the analysis of logical forms that it was introduced there.

Here in effect is the model around which I am proposing to you for today to centre your reflection. Here is a dial in which we are going to put vertical traits (subject). The trait function is going to fulfil here that of the subject and the vertical function, which is moreover chosen simply as support, that of attribute. I might well have said that I was taking the unary term as attribute but for the representative and imaginable aspect of what I have to show you, I am making them vertical.

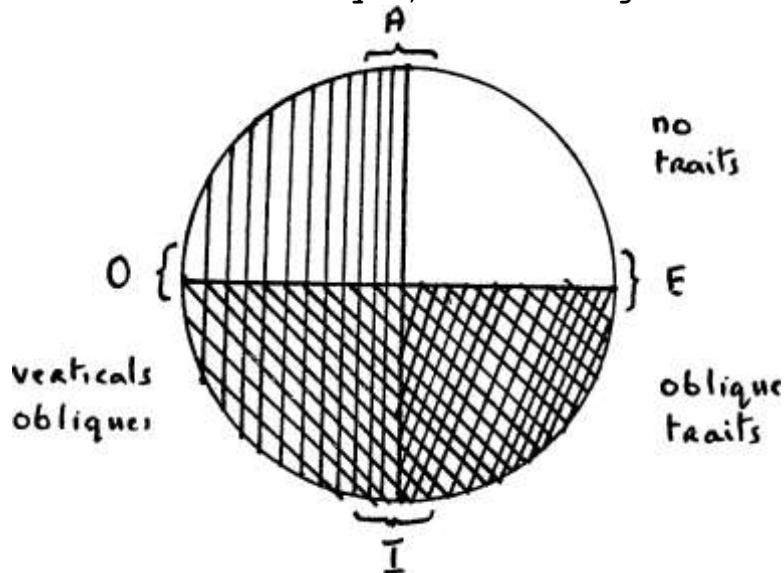

(21) Here, we have a segment of the dial where there are vertical traits, but also oblique traits, here there are no traits. What this is designed to illustrate, is that the universal/particular distinction, in so far as it forms a couple distinct from the affirmative/negative opposition is to be considered as a completely different register from the one that with more or less skill commentators from Apuleius on, thought that they should direct in the very ambiguous sliding and confusing formulae which are called respectively quality and quantity, and to oppose it in these terms. We will call the universal/particular opposition an opposition of the order of lexis, which is for us legein; I read and moreover I choose, very exactly linked to this function of the extraction, the choice of the signifier which is for the moment, the terrain, the footbridge on which we are in the process of advancing. This to distinguish it from the phasis, namely from something which here is proposed as a word through which I engage myself as regards the existence of this something which is put in question by the first lexis. And in effect, as you are going to see, about what am I going to be able to say that everything that is vertical is true? [or: All traits are vertical.]

Naturally, about the first sector of the dial 1, but you should note also about the empty sector 2: if I say, all traits are vertical, that means that when there is no vertical, there are no traits? In any case, it is illustrated by the empty sector of the dial: not only does the empty sector not contradict, is not contrary to the affirmation: "all traits are vertical", it (22) illustrates it. There is no vertical trait in this sector of the dial.

Here the universal affirmative is illustrated then by the two first sectors. The universal negative is going to be illustrated by the two sectors on the right, but what is in question there will be formulated by the following articulation: no trait is vertical, there are not in these two sectors any traits. What is to be remarked, is the common sector 2 which includes these two propositions, which according to the formula, the classical doctrine, apparently cannot be true at the same time.

What are we going to find following our gyratory movement, which has thus begun very well here as a formula like this, to designate the two other possible 2 by 2 groupings of the dials. Here, we are going to see the truth of these two dials in an affirmative form. There are - I am saying it in a phasic (phasis) fashion: I note the existence of vertical traits - there are vertical traits, there are some vertical traits, that I can find either here, or here?

Here, if we try to define the distinction between the universal and the particular, we see which are the two sectors which correspond to the particular enunciating. Here there are non-vertical traits "non nullus, etc...".

Just as earlier, we were suspended for an instant at the ambiguity of this repetition of negation, not not is very far from being necessarily the equivalent of yes and this is (23) something to which we will have to return subsequently.

What does that mean? What interest is there for us in making use of such an apparatus? Why am I trying to detach for you this plane of the lexis from the plane of the phasis? I am going towards it immediately and not in a roundabout way. And I am going to illustrate it.

What can we say, we analysts, what does Freud teach us since the meaning of what is called a universal proposition has been completely lost, ever since precisely a formulation whose chapter-heading one can put at the Eulerian formulation which manages to represent all the functions of the syllogism for us by a series of little circles, either excluding one another, overlapping, intersecting one another in other words, and properly speaking in extension, to which there is opposed the comprehension which would be distinguished simply by some inevitable manner or other of understanding, of understanding what? That the horse is white, what is there to understand?

What we contribute to renew the question is the following: I am

saying that Freud promulgates, puts forward the following formula: the father is God or every father is God. There results, if we maintain this proposition at the universal level, the one of there is no other father but God, which on the other hand as regards existence is in Freudian reflection rather aufgehoben, rather put in suspension, indeed in radical doubt.

(24) What is involved, is that the order of function that we are introducing with the name of the father is this something which, at the same time, has its universal value, but which leaves up to you, to the other, the task of determining whether there is or not a father of this stature. If none exists, it is still true that the father is God, simply the formula is only confirmed by the empty sector of the dial, thanks to which at the level of the phasis we have: there are fathers who fulfill more or less the symbolic function that we ought to denounce as such, as being that of the name of the father, there are those who, and there are those who are not. But that there are those who are not, who are not in all cases, which is supported here by this sector 4, is exactly the same thing which gives us a basis and support for the universal function of the name of the father; for grouped with the sector in which there is nothing 2, it is precisely these two sectors taken at the level of the lexis which are found because of this, because of this supported sector which complements the other sector, which gives its full import to what we can enounce as universal affirmation.

De^h₆

I am going to illustrate it differently, because moreover, up to a certain point the question was able to be posed of its value, I mean with respect to a traditional teaching which ought to be the one that I contributed the last time concerning the small i.

(25) Here the professors are in dispute: what are we going to say? The professor, the one who teaches, should teach what? What others have taught before him, namely that he bases himself on what? On what has already undergone a certain lexis. What results from every lexis, is precisely what is important for us on this occasion, and at the level of what I am trying to sustain for you today: the letter. The professor is literate in his universal character, he is the one who bases himself on the letter at the level of a particular enunciation, we can now say that he can be half-and-half, he cannot be entirely literate. There will result from it that all the same one cannot say that any professor is illiterate, there will always be in his case a few letters.

It nevertheless remains that if, by chance, there was an angle from which we could say that there are some eventually from a certain angle who are characterised as giving rise to a certain ignorance of the letter, this would not prevent us for all that from looping the loop and from seeing that the return and the foundation, as one might say, of the universal definition of professor is very strictly in the following, it is that the identity of the formula that the professor is the one who is

identified to the letter imposes, requires even the commentary that there can be illiterate (analphabètes) professors. The negative space 2 as essential correlative for the definition of universality is something that is profoundly hidden at the level of the primitive lexis.

This means something: in the ambiguity about the particular support that we can give in the engagement of our word to the name of the father as such, it nevertheless remains that we (26) cannot bring it about that anything which drawn up into the human atmosphere, if I can express myself in this way, is able, as one might say, to consider itself as completely disengaged from the name of the father, that even here (void) where there are only fathers for whom the function of father is, if I may express myself in this way, one of pure loss, the father who is not the father, the lost cause, on which I ended my seminar of last year, it is nevertheless in function of this collapse, with respect to a first lexis which is that of the name of the father, that this particular category is judged.

Man can only ensure that his affirmation or his negation with everything that it engages: this person here is my father, or that one is his father, is not entirely suspended from a primitive lexis of which, of course, it is not the common meaning, the signified of the father that is in question, but something to which we are here provoked to give its true support and which is legitimate even in the eyes of professors, who, as you see, would be in great danger of being always left in some suspense as regards their real function even in the eyes of professors, ought to justify me trying to give, even at their level of professors, an algorithmic support to their subject-existence as such.

All traits are vertical
 (=when there is no vertical
 there is no trait)
 All fathers are God
 (there is no other father
 but God)
 The professor bases himself
 on the letter
 There are some vertical
 traits (A.P)
 There are some fathers
 who fulfill + or - the
 symbolic function of the
 name of the father.
 The professor only
 partially

bases himself on the
 letter
 N
 There is neither
 trait, nor vertical
 name of the father
 illiterate professor
 Father not father
 Lost cause
 No trait is vertical
 Some of them do not
 exist
 No professor bases
 himself on the lexis

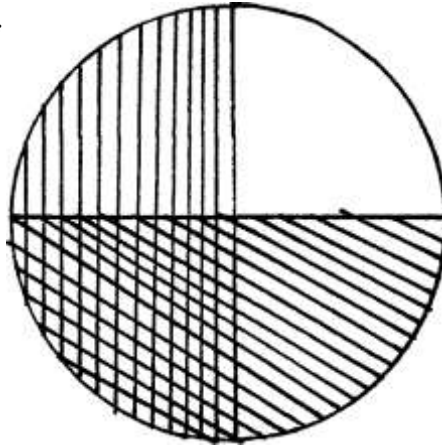

LEXIS

PHASIS

Seminar 9: Wednesday 24 January 1962

The important thing as far as we are concerned for the continuation of our seminar, is that what I said last evening obviously concerns the function of the object, of the little o in the identification of the subject, namely something which is not immediately within hand's reach, which is not going to be resolved immediately, of which last evening I gave, as I might say, an anticipatory indication by making use of the theme of the three caskets. This theme of the three caskets clarifies my teaching a good deal, because if you open what is bizarrely called Essais de Psychologie Appliquée and you read the article on the three caskets you will see that when all is said and done it will not fully satisfy you; you do not know very well what our father Freud is getting at. I believe that with what I told you last evening which identifies the three caskets to the demand, a theme to which, I believe, you have become accustomed for a long time, which says that in each one of these three caskets - without this there would be no riddle, there would be no problem - there is the little o, the object which in so far as it interests us analysts, but not at all necessarily - is the object which corresponds to demand. Not at all necessarily nor the contrary either, because without that there would be no difficulties. This object, is the object of desire, and where is desire? It is outside; and where it truly is, the decisive point, is you, the analyst, in so far as your desire should not be deceived about the object of the subject's desire. If this (2) were not the way things were, there would be no merit in being an analyst.

There is a something which I tell you also in passing, which is that I already put the accent before an audience which was supposed not to know on something into which I have not perhaps sufficiently put my big heavy boots here, namely that the system of the unconscious, the psi-system, is a partial system. Once again, I repudiated, obviously with more energy than motives, given that I had to go quickly, the reference to totality, which does not prevent one speaking about the partial. I insisted in this system on its extra-flat character, on its surface character which Freud insists on with all his might all the time. One cannot but be astonished that this should have engendered the metaphor of depth-psychology. It is quite by chance that a little earlier before coming here I found a note that I had taken from The ego and the id: " The ego is first and foremost a bodily ego; it is not merely a surface entity but is itself the

projection of a surface." [SE XIX 26] It is a nothing: when one reads Freud, one always reads him in a certain fashion that I would describe as deaf.

Let us now take up again our pilgrim's staff, let us take up again where we are, where I left you the last time, namely on the idea that negation, if it is indeed somewhere at the heart of our problem which is that of the subject, is not already, immediately, even if one looks at its phenomenology, the simplest thing to handle. It is in many places, and then it happens all (3) the time that it slips through your fingers. You saw an example of it the last time, for a moment in connection with the "non nullus homo non mendax", you saw me putting in this non, taking it out and putting it back again; you see this every day. It was pointed out to me in the interval that in the discourses of the one that someone, in a note, my poor dear friend Merleau-Ponty, called the Great Man who governs us, in a discourse that the aforesaid great man pronounced one hears "on ne peut pas ne pas croire que les choses se passeront sans maF" (one cannot not think that things will happen without harm). The exegesis on this: what does he mean? The interesting thing, is not so much what he means, it is that obviously we understand very well precisely what he means and that if we analyse it logically we see that he is saying the opposite.

This is a very pretty formula which you ceaselessly slips into when you say to someone "vous n'etes pas sans ignorer" (you cannot fail to be ignorant of [to realise]). It is not you who are wrong, it is the relationship of the subject to the signifier which emerges from time to time. It is not simply tiny paradoxes, slips, that I am pinpointing here in passing. We will rediscover these formulae at the appropriate bend in the road. And I think I am giving you the key to why "you cannot fail to realise", only means what you mean. In order that you may find your bearings here, I can tell you that it is indeed by exploring it that we will find the proper weight, the proper incline of this balance on which I place before you the relationship of the neurotic to the phallic object when I tell you in order to catch this relationship, one must say: "il n'est pas sans l'avoir" (he is not without having it). This obviously does not mean that he has it. If he had it, the question would not arise.

(4) In order to get there, let us begin from a little reminder about the phenomenology of our neurotic concerning the point that we are at in it: his relationship to the signifier. For the last number of times I have begun to make you grasp the sort of writing, of original writing there is in the business of the signifier. It must really have all the same occurred to you that it is with this that the obsessed subject is dealing all the time: ungeschen machen, to undo something. What does that mean, what does that involve?

Obviously, it can be seen in his behaviour: what he wants to abolish is what the annalist writes throughout his history, the annalist - with two n's - that he has in himself. It is the annals of the affair that he would like to efface, to scratch

out, to abolish. From what angle does Lady Macbeth's discourse reach us when she tells us that all the waters of the sea would not wash away this little spot if not through some echo which guides us to the heart of our subject? Only the point is, in washing away the signifier, since it is clear that this is what is involved - in his way of behaving, in his way of effacing, in his way of scratching out what is written, what is much less clear to us, because we know a little bit more about it than the others, is what he is trying to obtain by doing that. This is why it is instructive to continue along the road that we are on, where I am leading you as regards how a signifier as such comes about. If this has such a relationship with the foundations of the subject, if no other subject is thinkable than this natural something, x , in as much as it is marked by the signifier, there must all the same be some source or other for that. We are not going to content ourselves with this sort of blindfolded truth. (5) It is quite clear that we must find the subject at the origin of the signifier itself; "in order to pull a rabbit out of a hat", this is how I began to spread scandal in my properly analytic remarks: the poor dear man who is now dead and who was so touching in his fragility, was literally exasperated by this reminder which I so persistently gave - because at that time it was a useful formula - that "in order to pull a rabbit out of a hat you must have put it in beforehand".

It must be the same for the signifier, and this is what justifies the definition of the signifier that I give you, its distinction from the sign: the fact is that if the sign represents something for someone, the signifier is articulated otherwise, it represents the subject for another signifier. This you will see sufficiently confirmed at every step provided you do not let go of the solid hand-rail. And if it represents the subject in this way, how is it done?

Let us come back to our starting point, to our sign, to the elective point at which we can grasp it as representing something for someone in a trace. Let us start from the track in order to track down our little affair.

A footprint, a track, Friday's footprint on Robinson's island: emotion, the heart racing before this trace. All this teaches us nothing, even if from this racing heart there results a whole lot of stamping around this trace; this could happen on coming across (6) any animal tracks but if coming on it unexpectedly I find the trace of something whose trace someone has tried to efface, or if even I no longer find the trace of this effort, if I have come back because I know - I am not any more proud of it because of that - that I left the trace, that I find that, without any correlative which allows this effacing to be attached to a general effacing of the traits of the configuration, one has well and truly effaced the trace as such, then I am sure that I am dealing with a real subject. Notice that, in this disappearance of the trace, what the subject is trying to make disappear is his own passage as a subject. The disappearance is redoubled by the disappearance that is aimed at which is that of the act itself of making disappear.

This is not a bad trait for us to recognise in it the passage of the subject when it is a question of his relationship to the signifier, in the measure that you already know that everything that I am teaching you about the structure of the subject, as we are trying to articulate it starting from this relationship to the signifier, converges towards the emergence of these moments of fading linked properly speaking to this eclipse-like pulsation of what only appears in order to disappear and reappears in order to disappear anew, which is the mark of the subject as such.

Having said this, if the trace is effaced, the subject surrounds its place with a ring (cerne) something which thenceforward concerns him; the mapping out of the place where he found the trace, well then, here you have the birth of the signifier. This implies a whole process involving the return of the last phase onto the first, that there cannot be any articulation of a signifier without these three phases. Once the signifier is (7) constituted, there are necessarily two others before. A signifier is a mark, a trace, a writing, but it cannot be read alone. Two signifiers is a bloomer, a cock-and-bull story. Three signifiers is the return of what is involved, namely of the first. It is when the pas (step) marked in the trace is transformed in the vocalisation of whoever is reading it into pas (not) that this pas, on condition that one forgets that it means the step, can serve at first in what is called the phonetics of writing, to represent pas, and at the same time to transform the trace of pas eventually into the pas of the trace.

I think that you can hear in passing the same ambiguity that I made use of when I spoke to you, in connection with the witticism, of the pas de sens, playing on the ambiguity of the word sens (meaning) with this leap, this breakthrough which takes hold of us when we start to have fun when we do not know why a word makes us laugh, this subtle transformation, this rejected stone which being taken up again becomes the cornerstone (pierre d'angle), and I would be quite happy to make a play on words with the TvR of the formula of the circle because moreover it is in it - I announced it to you the other day in introducing the minus 1 - that we will see that there is measured, as I might say, the vectorial angle of the subject with respect to the thread of the signifying chain.

It is here that we are suspended and it is here that we should habituate ourselves a little to displacing ourselves, on a substitution through which that which has a meaning is transformed into an equivocation and finds its meaning again. It is in the very syncopes of this ceaselessly turning articulation of the play of language that we have to locate the (8) subject in its diverse functions. My illustrations are never a bad way of adapting a mental eye in which the imaginary plays a great part. It is for this reason that, even if it is a detour, I do not think it's a bad thing to rapidly sketch out for you a little remark simply because I find it at this point in my notes.

I have spoken to you more than once, in connection with the signifier, about the Chinese character, and I am very keen to

dispel for you the idea that its original is an imitative figure. There is an example of it which I only took because it is the one which was of most use to me, I took the first of those which are articulated in these examples, these archaic forms in the work of Karlgren which is called Grammata Serica, which means exactly "Chinese signifiers".

The first one that he makes use of in its modern form is the following, it is the character Kho which means power. In

𠂇

the Tch ouen which is an erudite work, precious for us both because its relatively ancient character and the fact that it is already very erudite, that is to say well furnished with interpretations which we may have to come back to. It seems that we would have good reason to trust the root that the commentator gives of it which is a very nice one, namely that it is a question of a schématisation of the shock of the column of

J

air which it has just expelled in the guttural occlusive against the obstacle which the back of the tongue against the palate opposes to it. This is all the more seductive in that, if you open a book on phonetics, you (9) will find an image which is more or less that in order to express for you the functioning of the occlusive:

J

And you must admit that it is not a bad thing that it should be that which was chosen in order to depict the word to see the possibility, the axial function introduced into the world by the advent of the subject right in the middle of the real. The ambiguity is complete. For a very great number of words are articulated as kho in Chinese, in which this would act for us as a phonetic, except for the fact that the complete outfit (les completes) presentifying the subject with its signifying framework, and this without any ambiguity and in all the characters, is the representation of the mouth:

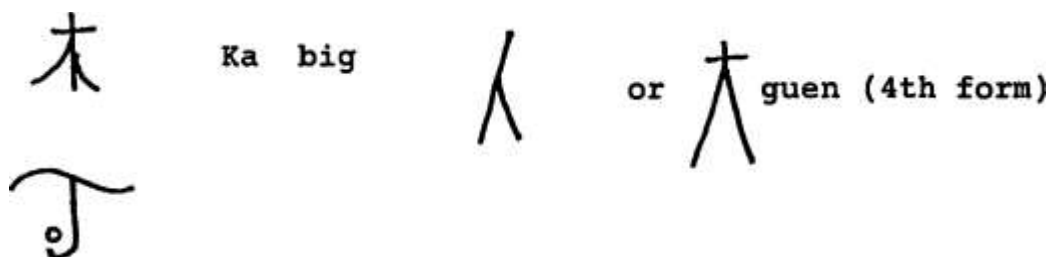

 𠂇 Ka big 𠂇 or 𠂇 guen (4th form)

Put this sign on top, it is the sign Ka which means big. It has obviously some relationship with the small human form, generally deprived of arms. Here, since it is a big person that is in question, there are arms. This has nothing to do with what happens when you have added this sign ta to the preceding signifier. Henceforth this is read as i, but this preserves the trace of an ancient pronunciation of which we have attestations thanks to the usage of this term in rhymes in the ancient poems, specifically those of Che King who is one of the most extraordinary examples of literary misadventure because destiny made him become the support of all sorts of moralising lucubrations, to be the foundation of a whole very twisted teaching of the mandarins on the duties of the sovereign, of the

(10) people and of everybody and anybody, even though what we have are obviously lovesongs which have a peasant origin. A little experience of Chinese literature - I am not trying to make you believe that mine is very great, I am not confusing myself with..... who, when he makes an allusion to his experience of China, gives us a paragraph that you can find in the books of Pere Wieger which are available to everybody.

In any case, others besides myself have lit up this path specifically Marcel Granet, whose beautiful book on the dances and legends and the ancient feasts of China you will lose nothing by opening. With a little effort you will be able to familiarise yourself with this really extraordinary dimension which appears of what one can do with something which reposes on the most elementary forms of signifying articulation. By chance, in this tongue, words are monosyllabic: they are superb, invariable, cubic, you cannot make a mistake in them. They are identified to the signifier it has to be said. You have groups of four verses, each one composed of four syllables, the situation is simple. If you see them and think that from that one can extract everything even a metaphysical doctrine which has no relationship with the original signification, it will begin, for those who have not got there yet to open your spirit. That is nevertheless the way it is: for centuries the teaching of morality and of politics was carried out on the basis of jingles which signify on the whole "I would really like to have sex with you", I am not exaggerating at all, go and see.

大
丁

(11) This means i, which is given the commentary: great power, enormous. This of course has absolutely no relationship with this conjunction, i does not mean great power any more than this little word for which in French there is really nothing which satisfies us: I am forced to translate it by impair in the sense that the word impair can take on of sliding, of fault, of failure, of something which is wrong, which is not working, so nicely illustrated in English by the word odd. And as I told you earlier, this is what

started me off on the Che King. Because of the Che King, we know that it was very close to kho, at least in this: the fact is that there was a guttural in the ancient tongue which gives the other implantation of the usage of this signifier to designate the phoneme i.

木 大
目 大
司 丁

If you add in front of it this , which is a determinant, that of the tree, and which designates everything that is wooden, you will have once things have got that far a sign which designates the chair, that is called i, and so on. It continues like that, there is no reason for it to stop. If you put here, at the place of the sign of the tree, the sign of the horse, that means to sit astride.

This little detour, I consider, because of its

usefulness for helping you to see that the relationship of the letter to language is not something which should be considered (12) along evolutionary lines. One does not begin from a dense, tangible origin in order to disengage from it an abstract form. There is nothing which resembles anything at all that can be conceived of as parallel to what is called the process of even only the concept of generalisation. One has a succession of alternations where the signifier comes back to strike, as I might say the flowing stream with the flails of its mill, its wheel raising up each time something streaming, in order to fall back again, to enrich itself, to complicate itself, without us ever being able at any moment to grasp what dominates in terms of the concrete starting point or of equivocation.

Here is what is going to lead you to the point where today the step that I have to get you to take, a great part of the illusions which bring us to a sharp halt, imaginary adhesions, of which we can say that it does not matter that everybody remains with their feet stuck in them like flies, but not analysts, is very precisely linked to what I would call the illusions of formal logic. Formal logic is a very useful science, in terms of the idea of it that I tried to highlight for you the last time, on condition that you perceive that it perverts you in the sense that because it is formal logic it should prevent you at every moment from giving the least meaning to it. That of course is what with time people came to. But I can assure you that this gives the very serious, courageous, honest men of symbolic logic who have been known for fifty years all sorts of trouble because it is not easy to construct a logic as it ought to be if it really answers to its title of formal logic, by basing oneself strictly on nothing but the signifier, by forbidding oneself (13) every relationship and therefore every intuitive support upon what may arise from the signified - in the case that we make mistakes in general it is on this that we take our bearings. I reason wrongly because in this case, something or other would result: my grandmother with her head upside down. What does that matter to us? In general we are not guided by this because we are very intuitive; if one does formal logic, one cannot but be.

Now the amusing thing is that the basic book of a symbolic logic, encompassing all the needs of mathematical creation, the Principia Mathematica of Bertrand Russell almost gets to this goal: they stop considering as a contradiction which would put in question the whole of mathematical logic, this paradox which is called that of Bertrand Russell the bias of which strikes at the value of what is called set theory. How is a set to be distinguished from a definition of class, the matter remains ambiguous because, what I am going to tell you and what is admitted by every mathematician, is namely that what distinguishes a set from a class, is nothing other than that the set will be defined by formulae which are called axioms, which will be posed on the blackboard in symbols reduced to letters to which there are joined some supplementary signifiers indicating relationships.

(14) There is absolutely no other specification of this logic which is called symbolic compared to traditional logic, except this reduction to these letters, I guarantee that you can believe me, without my going any further into examples. What then is the virtue, which must necessarily be somewhere, that it should be because of this single difference that there were able to be developed a pile of consequences whose incidence I assure you in the development of something which is called mathematics is not slight compared to the apparatus which was at peoples' disposal for centuries and the compliment paid to it of not having budged between Aristotle and Kant is turned against it. It is a good thing, if all the same things have begun to scoot along as they have done - because the Principia Mathematica comprises two big volumes and they are only of very slight interest - but after all (15) if the compliment is turned against itself, it is indeed because the previous apparatus for whatever reason it may be was found to be singularly stagnant.

So then, starting from there, how do the authors come to be astonished at what is called Russell's paradox?

Here is Russell's paradox: people speak about the set of all the sets which do not include themselves. I must clarify a little this story which may appear dry to you at a first approach. I indicate it to you right away. If I interest you in it, at least I hope, it is with this aim that it has the closest relationship - and not simply a homonymic one, precisely because it is a matter of a signifier and that consequently it is a matter of not understanding - with the position of the analytic subject, in so far as he also, in another sense of the word understand and if I tell you not to understand it is in order that you may understand in all the ways that he also does not include himself.
[Comprehendre = to include or to understand]

To go through this is not useless, as you are going to see, because by taking this route we are going to be able to criticize the function of our object. But let us pause for a moment at these sets which do not include themselves. It is necessary obviously to conceive of what is in question to begin with, because in communication we cannot all the same not concede intuitive references to ourselves, because you already have the intuitive references. They must then be upset in order to put others in their place. Since you have the idea that there is a class and that there is a mammal class, it is necessary all the (16) same that I should try to indicate to you that it is necessary to refer oneself to something else. When one enters into the category of sets, it is necessary to refer oneself to the library classification which some people are so fond of, a classification composed of decimals or something else; but when one has something written, it has to be put somewhere, one must know automatically how to find it. So then, let us take a set which includes itself, let us take for example the study of humanities in a library classification. It is clear that it will have to be put within the works of humanists about the humanities; the set of the study of humanities ought to include all the works concerning the study of humanities as such.

But considering now the sets which do not include themselves; this is no less conceivable, it is even the most ordinary case. And since we are set theorists and since there are already a class of sets which include themselves, there is really no objection to us making the opposite class - I am using class here because it is indeed here that the ambiguity is going to reside: the class of sets which do not include themselves, the set of all the sets which do not include themselves. And it is here that the logicians begin to rack their brains, namely that they say to themselves: this set of all the sets which do not include themselves, does it include itself or does it not include itself? In one case or the other it is going to collapse into contradiction. Because if, as it might appear, it includes (17) itself, we find ourselves in contradiction with the start which said that it was a question of sets which did not include themselves. On the other hand, if it does not include itself, how can we except it precisely from what is given by this definition, namely that it does not include itself?

This may seem rather naive to you, but the fact that this strikes, to the extent that it brings them to a halt, logicians who are precisely not the kind of people to pause at a stupid difficulty, and if they sense there something that they can call a contradiction putting their whole edifice in question, it is indeed because there is something that ought to be resolved and which concerns, if you will listen carefully to me, nothing other than the following, which concerns the only thing that the logicians in question do not exactly have in view, namely that the letter that they make use of is something which has in itself powers, a mainspring, to which they do not seem to be at all completely accustomed. Because if we illustrate this as an application of our statement that it is a matter of nothing other than the systematic usage of a letter, to reduce, to reserve for the letter its signifying function in order to make there repose on it, and on it alone, the whole logical edifice, we arrive at this very simple thing that it is altogether and quite simply, that this comes back to what happens when we charge the letter a, for example, if we set about speculating on the alphabet, with representing as letter a all the other letters of the alphabet.

It must be one thing or the other: either we enumerate the other letters of the alphabet from b to z, which means that the letter (18) a will represent them unambiguously without for all that being included itself; but it is clear that on the other hand, representing these letters of the alphabet qua letter, it comes quite naturally I would not even say to enrich but to complete at the place from which we have withdrawn, excluded it, the series of letters, and simply by the fact that, if we begin from the fact that a - this is our starting point as regards identification - fundamentally is not at all a, there is no difficulty here, the letter a, inside the parenthesis in which there are oriented all the letters that it has symbolically subsumed, is not the same a and is at the same time the same.

There is no difficulty of any kind here, there should all the less be any since those who see one are precisely those who

invented the notion of set in order to face up to the deficiencies of the notion of class and as a consequence suspect that there must be something else in the function of the set than there is in the function of the class.

But this interests us because what does that mean?

As I indicated to you last evening, the metonymical object of desire, the one which in every object represents this elective little o, in which the subject loses himself, when this object comes to metaphorical birth, when we come to substitute it for the subject who, in the demand has a syncope, has fainted, no trace: S, we reveal the signifier of this subject, we give it its name: the good object. The mother's breast, the mamma, here is the metaphor in which, let us say, there are caught up all the (19) articulated identifications of the subject's demand; his demand is oral, it is the mother's breast which takes them up into its parenthesis it is the A which gives their value to all these unities which are going to be added together in the signifying chain: A (+ I + I + I).

The question that we have to pose, is to establish the difference between this usage that we are making of the mamma and the function that it takes on by the definition, for example, of the mammal class. The mammal is recognised by the fact that it has mammae. Between ourselves it is rather strange that we are so little informed about what in fact is effectively done with them in each species. The ethology of mammals is still very much behind because we are, on this subject as in formal logic, more or less no further than the level of Aristotle (the excellent work Historia Animalium). But for us, what does it mean for us to say the signifier mamma in so far as it is the object around which we substantify the subject in a certain type of relations described as pregenital?

It is quite clear that we make a completely different use of it, much closer to the manipulation of the letter E in our set paradox, and in order to show it to you, I am going to show you the following: A (+ 1 + 1 + 1) the fact is that among these ones of the demand whose concrete significance we have revealed, is there or is there not the breast itself? In other words, when we speak about oral fixation, the latent breast, the present one, the one after which your subject goes ah, ah, ah, is it mammary? (20) It is quite obvious that it is not because your oral types who adore breasts, adore breasts because breasts are a phallus. And it is even because of that that it is possible for the breast to be also a phallus, for Melanie Klein to make it immediately appear, just as quickly as the breast, from the beginning, telling us that after all it is a little breast that is more convenient, more portable, nicer.

You see clearly that to pose these structural distinctions can lead us somewhere, in the measure that the repressed breast re-emerges, appears again in the symptom, or even simply in something that we have not qualified otherwise: the function on the ladder of perversity of producing this something else which

is the evocation of the object phallus.

This is written as follows:

$$\frac{\$}{\text{breast}} \swarrow \text{breast } (o) \\ \text{phallus}$$

What is the o ? Let us put in its place the little ping-pong ball, namely nothing, anything at all, any support whatsoever of the alternating operation of the subject in the Fort-Da. There you see that it is strictly speaking a question of nothing other than the passage of the phallus from $o+$ to $o-$ and that in this way we see in the identification relationship, because we know that in what the subject assimilates it is him in his frustration, we know that the relationship of $\$$ to this $\frac{1}{A}$, he the 1 qua assuming the signification of the Other as such, has the closest relationship to the realisation of alternation.

$$(o \times - o)$$

(21) This product of o by $-o$, which formally gives a minus o squared: $-o^1$, we will get closer to why negation is irreducible: when there is affirmation and negation, the affirmation of the negation gives a negation, the negation of the affirmation also - we see there being highlighted here in this very formula of $-o^1$. we rediscover the necessity of the bringing

$$\sqrt{-1}$$

into play at the root of this product of the root of -1 ,

What is involved is not simply the presence or the absence of small o , but the conjunction of the two, the cut. It is the disjunction between the o and the $-o$ that is involved, and it is here that the subject comes to take up his dwelling as such, that identification has to be made with this something which is the object of desire. It is for this reason that the point to which, as you will see, I led you today is an articulation which will be of use to you in what follows.

Next seminar 21/2/62.

Seminar 10: Wednesday 21 February 1962

I left you the last time with the apprehension of a paradox concerning the modes of appearance of the object. This thematic starting from the object qua metonymical was questioning itself about what we are doing when we make this metonymical object appear as a common factor of this line.

Sr
sd

This line, which is called that of the signifier, whose place I designated by that of the numerator in the great Saussurian fraction: signifier over signified, this is what we were doing when we made it appear as a signifier, when we designated this object as the object of the oral drive, for example. As this new type designated the genus of the object, in order to make you grasp it, I showed you the new element contributed to logic by the mode in which the signifier is used in mathematics, in set theory, a mode which is precisely unthinkable if we do not put in the forefront of it as constitutive this famous paradox called Russell's paradox. In order to make you put your finger on what I have started from, namely the signifier as such is not alone not subject to what is called the law of contradiction, but is even properly speaking its support, namely that the a is usable as a signifier in so far as a is not a; from which it resulted that the object of the (2) oral drive in so far as we consider it as the primordial breast, in connection with this generic mamma of analytic objectalisation, the question could be posed: in these conditions is the real breast mammary? I told you no, as is quite obvious, since in the whole measure that the breast is found to be eroticised in oral eroticism, it is in so far as it is something completely different to a breast, as you know well, and someone after a class, came up to me saying: in that case is the phallus phallic?

What has to be said, is that it is in so far as the signifier phallus is what comes at a certain stage as a factor revealing the meaning of the signifying function, it is in so far as the phallus comes to the same place in the symbolic function where the breast was and in so far as the subject is constituted as phallic that the penis, which for its part is the inside of the parenthesis of the set of objects which for the subject have arrived at the phallic stage, that the penis, one can say, not alone is not any more phallic than the breast is mammary, [but] that things are posed much more seriously, namely that the penis-part of the real body, falls under the influence of this

threat which is called castration.

It is because of the signifying function of the phallus as such that the real penis falls under the influence of what was first understood in analytic experience as a threat namely the threat of castration.

(3) Here therefore is the path on which I am leading you. I am showing you here its goal and its aims. It is now a question of going along it step by step, in other words of rejoining what since our beginning this year, I am preparing and approaching little by little, namely the privileged function of the phallus in the identification of the subject.

Let us understand carefully that in all this, namely the fact that this year we are talking about identification, it is namely because of the fact that from a certain moment of the Freudian work, the question of identification comes into the foreground, comes to dominate, comes to remodel the whole Freudian theory. It is in so far - one blushes almost to have to say it - that from a certain moment, for us after Freud, for Freud before us, the question of the subject is posed as such, namely who, who is there, who is functioning, who is speaking, who is a lot of other things as well and it is in so far as it might well have been expected in a technique which is a technique generally speaking of communication, of speaking to one another, and in a word of relating: it was all the same necessary to know who is speaking to whom.

It is indeed for this reason that this year we are doing logic. I cannot do anything about it: it is not a question of knowing whether this pleases me or whether it displeases me. It does not displease me, it may not please others. But what is certain is that it is inevitable. It is a question of knowing what logic this draws us into. You were well able to see that already I (4) have shown you - I strive to take as many shortcuts as possible, I assure you that I am not playing truant - where we situate ourselves with respect to formal logic and undoubtedly it is not that we do not have our own word to say about it.

I remind you of the little dial which I constructed for your use and to which we will perhaps have occasion to return on more than one occasion unless, because of the speed that we are forced to go in order to arrive at our goal this year, it is to remain for some months or some years yet a proposition left hanging for the ingenuity of those who take the trouble to go back on what I am teaching you.

But surely it is not only formal logic that is involved. Is it a matter - and this is what is called ever since Kant, I mean in a well constituted fashion since Kant a transcendental logic, in other words the logic of the concept? Surely not that either. It is even rather striking to see the degree to which the notion of concept is apparently absent from the functioning of our categories.

What we are doing, it is not worth the effort of giving ourselves a lot of trouble for the moment in order to pinpoint it more precisely, is a logic of which at first some said that I tried to construct a sort of elastic logic. But after all, this is not (5) enough to constitute something very reassuring for the spirit. We are constructing a logic of the functioning of the signifier, for without this reference constituted as primary, fundamental, of the relationship of the subject to the signifier, and what I am putting forward is that it is properly speaking unthinkable even for one to situate the error in which the whole of analysis progressively became engaged and which is caused precisely by the fact that it did not carry out this critique of transcendental logic that is strictly required by the new facts that it brings forward.

This - I am going to tell you its secret which has not in itself any historical importance but I think I can all the same communicate it to you as a stimulus - this led me, for a long or a short time according to whether I was separated from you and from our weekly encounters, led me to put my nose again, not at all as I did two years ago into the Critique of Practical Reason but into the Critique of Pure Reason. Since it happened by chance that I had through forgetfulness only brought my German copy, I did not reread it completely, but only the chapter called "The introduction to the transcendental analytic", and while deploring that the ten or so years during which I have been addressing myself to you have not had, I believe, much effect as regards the propagation among you of the study of German, which never fails to astonish me, which is one of these little facts which makes me sometimes reflect my own image to myself as being like that of the personage in a well known Surrealist film called Le Chien Andalou, the image of a man who with the help of two (6) ropes, drags behind him a piano on which there repose (no allusion meant) two dead donkeys. That aside, let those at least who already know German not hesitate to re-open the chapter that I am designating for them of the Critique of Pure Reason. This will certainly help them to centre correctly the kind of reversal that I am trying to articulate for you this year.

I think I can very simply recall to you that its essence depends on the radically other, excentric fashion in which I am trying to make you understand a notion which is the one that dominates the whole structuring of the categories in Kant. This is why he is only putting the purified full-stop, the completed story, the final full-stop to what dominated philosophical thought until here in some sort of way he completes it: the function of Einheit, which is the foundation of every synthesis, of the a priori synthesis, as he puts it, and which seems in effect to impose itself from the time of its progression in Platonic mythology as the necessary path: the One, the big 1 which dominates all thinking from Plato to Kant, the One which for Kant, qua synthetic function, is the very model of what in every a priori category brings with it, he says, the function of a norm, to be understood as a universal rule. Well then, let us say, to add its tangible point to what, since the beginning of this year, I have been articulating for you that if it is true

that the function of the One in identification, as the analysis of Freudian experience structures and decomposes it, is that, not of Einheit, but what I tried to make you sense concretely since (7) the beginning of the year, as the original accent of what I called for you the unary trait, namely something completely different to the circle which gathers together, at which in short there ends up at a summary level of imaginary intuition all logical formalisation, not the circle, but something completely different: namely what I called for you a 1: this trait, this unsituatable thing, this aporia of thinking which consists in the fact that precisely it is all the more purified, simplified, reduced to anything whatsoever with a sufficient abatement of its appendices, can end up by reducing itself to that: a 1; what is essential in it, what constitutes the originality of this, of the existence of this unary trait and of its function and how it is introduced is precisely what I am leaving in suspense, because it is not so clear that it is through man, it is possible from a certain angle, in any case put in question by us that it is from there that man emerged.

Therefore, the paradox of this One is precisely the following: it is that the more it resembles, I mean the more everything which belongs to the diversity of appearances is effaced from it, the more it supports, the more it incarnates I would say, if you will allow me this word, difference as such.

The reversal of the position around the One means that from the Kantian Einheit, we consider that we pass to Einzigkeit to unicity expressed as such. If it is through this, as I might say, that I am trying, to borrow an expression from a title that I hope is celebrated for you, from a literary improvisation by Picasso if it is through this that I chose this year to try to do what I believe I am trying to get you to do, namely to catch (8) desire by the tail, if it is in this way, namely not by the first form of identification defined by Freud, which is not easy to handle, that of the Einverleibung, that of the consumption of the enemy, of the adversary, of the father, if I started from the second form of identification, namely from this function of the unary trait, it is obviously with this goal in mind; but you see where the reversal is, it is that this function, (I believe that it is the best term for us to take because it is the most abstract, it is the most supple, it is properly speaking the most signifying, it is simply a big F) if the function that we are giving to the One is no longer that of Einheit but that of Einzigkeit, it is because we have passed - this is something that all the same we would do well not to forget, which is the novelty of analysis - from the virtues of the norm to the virtues of the exception. Something which you have remembered all the same a little bit and with good reason: the tension of the thinking which accommodates itself to it by saying: "the exception confirms the rule". Like a lot of idiocies it is a profound idiocy. It is enough simply to know how to tease it out. If I I had done nothing other than to take up again this quite luminous idiocy like one of these little search-lights that one sees on top of police cars it would already be a little gain on the plane of logic.

But obviously it is a lateral benefit. You will see this, especially if some of you, perhaps some of you might go so far as to devote themselves, even to the point of giving in my place someday a little resume of the way in which the Kantian analytic would have to be repunctuated. You may well imagine that there (9) are the beginnings of all that: when Kant distinguishes universal judgement and particular judgement and when he isolates singular judgement by showing in it the profound affinities with universal judgement - I can say what everybody had perceived before him - but in showing that it is not enough to gather them together in so far as the singular judgement has indeed its independence, there is here something like a tooting stone, the beginnings of this reversal that I am speaking to you about.

This is only an example.

There are many other things which initiate this reversal in Kant. What is curious, is that it had not been done even earlier. It is obvious that what I was alluding to in passing, the time before last, namely the aspect which scandalised so much Mr Jespersen the linguist - which proves that the linguists are not at all provided with any infallibility - namely that there is some paradox in the fact that Kant put negation under the rubric of categories designating qualities, namely as a second moment as one might say, of the categories of quality, the first being reality, the second being negation and the third being limitation.

This thing which surprises and which it surprises us that it should surprise so much this linguist, namely Mr Jespersen, in this very long work on negation that he published in the annals of the Danish Academy. One is all the more surprised that this long article on negation is precisely written, in short, from one (10) end to the other, to show us that linguistically negation is something which can only be sustained by - as I might say - a perpetual overbidding. It is therefore not such a simple thing to put it under the rubric of quantity where it might be confused purely and simply with what it is in quantity, namely zero.

But precisely I have already given you enough indications about this; I give the reference to those who are interested by this: the big work of Jespersen is really something considerable, but if you open the dictionary of Latin etymology by Ernout and Meillet and consult simply the article ne you will understand the historical complexity of the problem of the functioning of negation, namely this profound ambiguity which brings it about that after having been this primitive function of discordance on which I have insisted as well as on its original nature, it is always necessary that it should support itself on something which is precisely this nature of the One in the way that we are trying to get closer to it here that linguistically negation is never a zero, but a not one to the point that the Latin sed non for example, to illustrate what you can find in this work published by the Danish Academy during the war of 1914 - and for that reason very difficult to find - the Latin non itself which seems to be the simplest form of negation in the world is already

an ne oinon, oinon, in the form of unum. It is already a not one and after a certain time, one forgets that it is a not one and a one is put after it again, and the whole history of negation is the history of this consumption by something which is where? It (11) is precisely what we are trying to get close to: the function of the subject as such.

It is for this reason that Pichón's remarks are very interesting because they show us that in French, one sees the two elements of negation operating so well, the relationship of the ne with the pas, that one could say that French in effect has this privilege, not unique moreover among other tongues, of showing that there is no veritable negation in French. What is curious moreover, is that they do not see that if this is the way things are, it should go a little bit further than the field of the French domain, if one can express oneself in that way. It is, in effect, very easy in all sorts of forms to understand that it is necessarily the same everywhere given that the function of the subject is not suspended at its root on the diversity of tongues. It is very easy to see that the not at a certain moment of the evolution of the English language is something like naught.

Let us go back in order that I may reassure you that we are not losing our goal. Let us begin again from last year from Socrates, from Alcibiades and from the whole clique who, I hope, provided a little diversion for you at that stage. It is a matter of connecting this logical reversal about the function of 1 with something with which we have been dealing with for a long time, namely desire; since because of the time that I have not spoken to you about it it is possible that things have become a little bit vague, I am going to give a little reminder which I believe it is just the moment to give in this presentation, this (12) year. As regards the following - as you remember, it is a discursive fact, that it was in this way that I introduced the question of identification last year, it was properly speaking, when I tackled what ought to be constituted for us about the narcissistic relationship as a consequence of the equivalence put forward by Freud between narcissistic libido and object libido. You know how I symbolised it at the time: a little intuitive schema, I mean something which is represented, a schema, not a schema in the Kantian sense. Kant is a very good reference. In French it is dull. M M have accomplished all the same quite a feat by turning the reading of The Critique of Pure Reason, which it is absolutely not unthinkable to say that from a certain angle can be read as an erotic book, into something absolutely monotonous and dusty. Perhaps thanks to my commentaries, you will manage, even in French, to restore to it this sort of spice that it is not exaggerated to say it involves. In any case, I had always allowed myself to be persuaded that it was badly written in German, because first of all the Germans, with certain exceptions have the reputation of writing badly, it is not true: The Critique of Pure Reason is written as well as Freud's books - and that is no small thing.

The schema is the following: subject

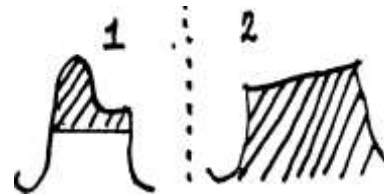

It concerned what Freud speaks to us about at this level of the "Introduction to narcissism" namely that we love the other from the same humid substance as the one of which we are the (13) reservoir, which is called libido, and that it is in so far as it is here that it can be there (see the schema) namely surrounding, swamping, wetting the object in front. The referring of love to humidity does not come from me, it is in the Symposium which we gave a commentary on last year.

The moral is: this metaphysics of love - because this is what is involved - the fundamental element of Liebesbedingung, of the condition of love, the moral is: in a certain sense I only love - what is called loving, what we call here loving, there is also the matter of what exists as a remainder beyond love, therefore what is called loving in a certain fashion - I only love my body, even when I transfer this love onto the body of the other. Of course a good amount of it still remains on my own. It is even indispensable, up to a certain point, even if only in the extreme case of what must of course function autoerotically, namely my penis, to take for simplicity the androcentric point of view. There is no problem about this simplification, as you will see, because this is not what interests us.

What interests us is the phallus. Now, I proposed to you implicitly, if not explicitly in the sense that it is even more explicit now than last year, I proposed to you to define with respect to what I love in the other who for his part is subject to this hydraulic condition of the equivalence of the libido, namely that when it increases on one side, it increases also on the other, what I desire, what is different in what I experience, (14) is what in the form of pure reflection of what remains invested of me whatever the circumstances is precisely what is lacking to the body of the other in so far as it is constituted from the point of view of desire by this impregnation of the humidity of love, at the level of desire, this body of the other, at least however little I love it, only takes on a value precisely from what it lacks, and it is very precisely for that reason that I was going to say that heterosexuality is possible, because we have to understand one another.

If it is true, as analysis teaches us, that it is the fact that the woman is effectively castrated from the penile point of view which frightens some people, if what we say there is not at all nonsensical - and it is not at all nonsensical because it is obvious, one meets it at every turn in neurotics - I insist: I am saying that it is well and truly there that we have discovered it, I mean that we are sure because it is there that the mechanisms operate with such subtlety that there is no other hypothesis possible to explain the way in which the neurotic establishes, constitutes his hysterical or obsessional desire.

Which will lead me this year to articulate completely for you the meaning of the desire of the hysteric as well as that of the

obsessional, and very quickly, because I would say that up to a certain point, it is urgent. If this how things are, it is even more conscious in the homosexual than in the neurotic: the homosexual tells you himself because it has all the same a very painful effect on him to be confronted with this being without a penis. It is precisely because of this that we cannot trust it all that much and moreover, we are right. It is for this reason that I take my reference from the neurotic.

(15) All this having been said, it remains indeed that there are still all the same quite a few people whom that does not frighten and that, as a consequence, it is not crazy - let us say simply, I am forced to tackle the thing like that, since after all, nobody has said it like that, when I will have said it two or three times to you, I think that this will end up by becoming quite obvious to you - it is not crazy to think that in the case of the beings who cannot have a normal, satisfying relationship I mean of desire with the partner of the opposite sex: not alone does it not frighten him, but it is precisely this which is interesting namely that it is not because the penis is not there that the phallus is not there. I would even say on the contrary. Which allows there to be rediscovered at a number of crossroads this in particular that what desire seeks is less the desirable in the other than the desiring, namely what is lacking in him, and there again I would ask you to recall that it is the first aporia, the first abc of the question, as it begins to be articulated when you open this famous Symposium which seems to have traversed the centuries only for the theology that can be constructed around it. I am trying to make something else of it, namely to make you grasp that on every line, what is spoken of effectively is what is in question, namely Eros.

I desire the other as desiring and when I say as desiring, I did not even say, I deliberately did not say as desiring me: because it is I who desire, and desiring desire, this desire could only be desire for me if I rediscover myself at this turning point (16) where of course I am, namely if I love myself in the other, in other words if it is myself that I love.

But then, I am abandoning desire. What I am in the process of accentuating, is this limit, this frontier which separates desire from love: which does not mean, of course, that they do not condition it in all sorts of ways - this is even the whole drama here - as I think ought to be the first remark that you should make to yourselves about your experience as an analyst, it being well understood that it happens as it does to many other subjects at this level of human reality and that it is often the common man who is closest to what I would call on this occasion the bone. What is to be desired is obviously always what is lacking, and it is indeed for that reason that in French desire is called desidorium which means regrets.

And this also connects up with what I accentuated last year as being the point always aimed at by the ethics of the passions, which is to bring about, I am not saying this synthesis, but this conjunction regarding which it is a question of knowing whether

precisely it is not structurally impossible, if it does not remain an ideal point outside the limits of the working drawing, which I called the metaphor of true love, which is the famous equation: $\frac{\text{ERON}}{\text{εΑΘΜΕΝΟΝ}}$ the eron substituting himself, the désirer

substituting himself for the desired at this point, and through this metaphor equivalent to the perfection of the lover as it is also articulated in the Symposium, namely this reversal of this (17) whole property of what one could call: the naturally loveable, the heartbreak in love which puts everything that can be desirable in itself outside the range of lovingness, as I might say, this noli me amare, which is the true secret, the true final word of the ideal passion of this courtly love whose term, which has so little to do with the present, I placed for very good reasons, I mean however confusing it has become, at the horizon of what I articulated last year, preferring to substitute for it as more present, more exemplary this order of experience, for its part not at all ideal, but perfectly accessible, which is our own under the name of transference and which I illustrated for you, already showed, illustrated in the Symposium under this quite paradoxical form of a properly speaking analytic interpretation by Socrates after the long mad exhibitionistic declaration, indeed, the analytic rule applied at full tilt to the discourse of Alcibiades.

No doubt, you have been able to retain the irony implicitly contained in something which is not hidden in the text, which is that the one whom Socrates desires at the time for the beauty of the demonstration is Agathon, in other words, the deconograph, the pure spirit, the one who speaks about love in the way in which one ought no doubt speak about it by comparing it to peace on the waves, in a frankly comic tone, but without doing it deliberately, and even without noticing it.

In other words what does Socrates mean?

Why would Socrates not love Agathon if precisely stupidity, like (18) M Teste, is precisely what he is lacking. Stupidity is not my strong point, it is a teaching, because that means - and this then is articulated literally - to Alcibiades: "my dear friend, talk on, because it is him that you also love". It is for Agathon this whole long discourse. Only, the difference, is that you for your part do not know what is in question: your strength, your mastery, your riches lead you astray, and in effect, we know enough about the life of Alcibiades to know that few things were lacking to him in the most extreme order of what one can have. In his own way very different to that of Socrates, he also was nowhere. Received moreover with open arms wherever he went, people always too happy to make such an acquisition. A certain atopia was his lot. He himself was too much of a burden. When he came to Sparta, he found simply that he was doing a great honour to the King of Sparta - this is reported in Plutarch, clearly articulated - by having a child with his wife for example, this to give you the style of the man, this is the least of it, there are some really hard men around.

But for Socrates, the important thing is not there. The important thing is to say: "Alcibiades, pay a bit more attention to your soul", which, believe me, I am well convinced of it, has not at all the same meaning in Socrates that it took on after the Platonic development of the notion of the one. If Socrates responds to him "I know nothing, except, perhaps about the nature of Eros", it is indeed because the outstanding function of Socrates was to have been the first to have conceived what the true nature of desire was.

(19) And it is exactly for that reason that beginning from this revelation up to Freud, desire as such in its function, desire qua the very essence of man as Spinoza says - and everyone knows what that means, man in Spinoza, is the subject, is the essence of the subject - that desire remained throughout this respectable number of centuries a function that is half, three quarters, four fifths hidden in the history of knowledge.

The subject involved, the one whose track we are following is the subject of desire and not the subject of love for the simple reason that one is not the subject of love: one is ordinarily, one is normally its victim, it is completely different.

In other words, love is a natural force, this is what justifies what is called Freud's zoological point of view. Love, is a reality, it is for this reason moreover that I tell you "the Gods are real". Love is Aphrodite who strikes. It was very well known in antiquity. This astonished nobody.

You will allow me a very nice play on words. It is one of my most divine obsessionals who produced for me a few days ago: "l'affreux doute de l'Hermaphrodite" (the awful doubt of the Hermaphrodite). I mean that I can do nothing less than think about it since obviously things have happened which have made us slide from Aphrodite to awful doubt.

(20) I mean: there is much to be said in favour of Christianity, I could not support it too much and especially as regards the disengaging of desire as such.

I do not want to deflower the subject too much, but I am determined on this point to put all sorts of considerations before you. That all the same to obtain this most praiseworthy of ends, this poor love should have been put in the position of becoming a commandment, is all the same to have dearly paid for the inauguration of this research, which is that of desire.

We of course, all the same, as analysts, should know how to summarise a little bit the question about the subject, that what we have well and truly advanced about love, is that it is the source of all evil. That makes you laugh. The least conversation is there to demonstrate to you that the love of the mother is the cause of everything. I am not saying that one is always right, but it is all the same on this path that we do our roundabout every day. It is what results from our daily experience.

Therefore, it is well posed that as regards the research into what the subject is in analysis, namely what one should identify him to, even if it were only in an alternating fashion, it could not be other than one of desire.

It is here that I will leave you today, not without pointing out to you that even though, of course, we are in a position to do it (21) much better than it was done by the thinker that I am going to name, we are not so much in no-man's-land.

I mean that immediately after Kant, there is someone who noticed it who was called Hegel whose whole Phenomenology of the Spirit starts from this, from Begierde. He made only one mistake, which is to have had no knowledge, even though one could designate its place, of what the mirror stage was.

Hence this irreducible confusion which puts everything under the angle of the relationship of the master and the slave and which makes this approach inoperative and makes it necessary to take up everything from there.

Let us hope, as regards ourselves, that encouraged by the genius of our master, we can complete in a more satisfactory fashion the question of the subject of desire.

Seminar 11: Wednesday 28 February 1962

People may find that I am busying myself here a little bit too much with what are called - God's curse on the name - the great philosophers. The fact is that perhaps not they alone, but they in an eminent way, articulate what one may well call a pathetic research because it always returns, if one knows how to consider it throughout all its detours, its more or less sublime objects, to this radical knot that I am trying to undo for you namely desire; it is to this that I hope, by enquiring into it if you are willing to follow me, to restore decisively its property as an unsurpassable point, unsurpassable in the very sense that I mean when I tell you that each one of those who can be described by this name of great philosopher cannot be surpassed on a certain point.

I believe that I have the right to confront myself, with your assistance, with such a task in so far as desire is our business as psychoanalysts. I believe that I am also required to stick to it and to ask you to do so with me because it is only by rectifying our perspective on desire that we can maintain analytic technique in its primary function, the word primary needing to be understood in the sense of what appeared first historically - there was no doubt about it at the beginning -: a truth function. Naturally, this is what encourages us to interrogate this function at a more radical level; this is the (2) one that I am trying to show you by articulating for you the following, which is at the basis of analytic experience, that we are enslaved as men, I mean as desiring beings, whether we know it or not, whether we think we want it or not to this truth function. Because, do I have to remind you that the conflicts, the impasses, which are the raw material of our press, can only be objectified by making intervene in their operation the place of the subject as such, qua bound as subject into the structure of the experience. This is the meaning of identification in so far as it is defined as such by Freud.

Nothing is more precise, nothing is more demanding than the calculation of the subjective conjuncture when one has found what I can call in the proper sense of the term, the sense in which it is employed in Kant, its practical reason. I prefer to call it that than to say the operational bias, because of what the term operational implies for some time now: a sort of avoidance of what is fundamental. Remember on this point what I taught you two years ago about this practical reason in so far as it involves desire. Sade is closer than Kant, even though Sade,

almost mad, as one might say, about his vision, cannot be understood except by being on this occasion referred to Kant's measure in the way I tried to do it.

Remember what I told you about it, about the striking analogy between the total exigency of the liberty of jpuissance in Sade, with the universal Kantian rule of behaviour. The function on which desire is founded in our experience makes manifest that it has nothing to do with what Kant distinguishes as the Wohl, by (3) opposing it to the Gut and to the good, let us say with well being, with the useful. This leads us to realise that this goes much further than this function of desire. It has nothing to do, I would say, in general with what Kant calls, in order to relegate it to a second rank in the rules of behaviour, the pathological.

Therefore, for those who do not remember very well the sense in which Kant employs this term, whom this lead into a misinterpretation, I will try to translate it by saying the protopathic, or again more generally what is too human in human experience, limits linked to convenience, to comfort, to dietary concessions. This goes further, it goes as far as to imply tissue thirst itself. Let us not forget the role, the function that I give to anorexia nervosa, as being that in whose first effects we can sense this function of desire and the role that I gave it by way of example in order to illustrate the distinction between desire and need.

Therefore however far convenience, comfort, concession may be from it will you not tell me that there is no doubt no compromise because we speak about it all the time. But the compromises that this function of desire has to pass through are of a different order to those linked for example to the existence of a community founded on biological association, because it is in this form that we have most conveniently to evoke, to recognise, to explain the function of compromise. You know well that at the point that we are at, if we follow Freudian thinking to the end, these compromises involve the relationship of a death instinct to a (4) life instinct, which are one and the other no less strange to consider in their dialectical relationships than in their definition.

To begin again, as I always do, at some point of every discourse that I address to you weekly, I remind you that this death instinct is not a gnawing worm, a parasite, a wound, not even a principal of contrariety, something like a sort of Ying opposed to the Yang, the alternating element. It is clearly articulated for Freud: a principle which envelopes all the detours of life, which life, which detours only find their meaning by rejoining it. To be honest, it is because they are scandalised that some people distance themselves from it; because here indeed we have no doubt returned, come back, despite all the positivist principles, it is true, to the most absurd properly speaking metaphysical extrapolation, in contempt of all the acquired rules of prudence. The death instinct in Freud is presented to us as that which for us, I am thinking in his place, is situated

from the sequellae of what we are here calling the signifier of life, because what Freud tells us about it is that the essence of life, reinscribed in the frame of death instinct is nothing other than the design, required by the law of pleasure, of realising, of always repeating the same detour in order to come back to the inanimate.

The definition of the life instinct in Freud - it is not vain to come back to it, to reaccentuate it - is no less strange because of the fact that it is appropriate always to re-underline that it (5) is reduced to Eros, to the libido. Notice carefully what that signifies. I will accentuate it through a comparison with the earlier Kantian position; but already you see here the point of contact to which we are reduced as regards the relationship to the body. It is a matter of a choice, and of one so obvious that in the theory this is materialised in these figures which it must not be in any way forgotten are new and also what difficulties, what aporias, indeed what impasses they oppose to our efforts to justify them, even to situate them, to define them exactly. I think that the function of the phallus, since it is that around which there comes to be articulated this Eros, this libido, sufficiently designates what I intend to highlight here. On the whole all the figures, to take up again the term that I have just employed, that we have to handle concerning this Eros, what have they to do with, what have they in common for example in order to make you sense the distance from the preoccupations of an embryologist about whom one cannot all the same say that he has nothing to do with it, with the life instinct, when he questions himself about what an organiser is in growth, in the mechanism of cellular division, the segmentation of skin layers, morphological differentiation? One is astonished to find it written somewhere or other by Freud that analysis might lead to some biological discovery or other. This is to be found on occasions, as far as I remember, in the Abriss. What got into him at that time? I ask myself what biological discovery has been made in the light of analysis? But moreover, since it is a question of highlighting here the limitation, the elective point of our contact with the body, in so far, of course, as it is the (6) support, the presence of this life, is it not striking that, in order to reintegrate into our calculations the function of the preservation of this body, it was necessary for us to pass through the ambiguity of the notion of narcissism which has been sufficiently designated. I am thinking, in order not to have to articulate it otherwise, about the very structure itself of the narcissistic concept, and the equivalence that is placed on it there with the liaison to the object, sufficiently designated, I am saying, by the accent put ever since "An introduction to narcissism" on the function of pain, and the first article in so far - reread this excellently translated article - as pain is not a signal of damage but an autoerotic phenomenon as I recalled not too long ago in a casual conversation, and in connection with a personal experience, to someone who is listening to me, the experience of one pain effaces that of another, I mean that in the present it is difficult to suffer two pains at the same time: one takes over, makes one forget the other as if the libidinal cathexis, even onto one's own body, showed itself in this case to

be subject to the same law which I would call that of partiality which motivates the relation to the world of the objects of desire.

Pain is not simply, as the technicians say, exquisite by nature; it is privileged, it can be a fetish. This in order to lead us to this point which I already, during a recent lecture, not here, articulated that it is of contemporary interest in our account to put in question what is meant by the subjective organisation that is designated by the primary process, what it means as regards what is and what is not its relationship to the body. It is here that, as I might say, the reference to, the analogy with the Kantian investigation is going to be of use to us.

(7) I apologise with all the required humility, to those who have an experience of the Kantian texts which gives them a right to some marginal observations when I go a little quickly in my reference to the essential of what the Kantian exploration brings us. We could also perhaps delay here on these meanderings around certain points at the expense of rigour, but is it not also the case that in following them too much we might lose something in terms of its massive reliefs on certain points, I am speaking about the Kantian critique and specifically about the one called that of pure reason.

In that case, have I not got the right to limit myself for a moment to the following which, for someone who has simply read once or twice with an intelligent attention the aforesaid Critique of Pure Reason, something moreover which is not contested by any commentator, that the categories described as those of pure reason undoubtedly require to function as such the foundation of what is called pure intuition, which is presented as the normative, I will go further, obligatory form of all sensible understandings. I am saying of all, whatever they may be. This is the way in which this intuition, which is ordered in categories of space and of time, finds itself designated by Kant as being excluded from what one can call the originality of sensible experience, of Sinnlichkeit, from which alone there can emerge, there can arise any affirmation whatsoever about palpable reality, these affirmations of reality remaining no less in their articulation subject to the categories of the aforesaid pure reason, without which they would not be able to be, not alone enounced, but even glimpsed. In that case, everything is (8) dependent on this principle of the so-called synthetic function, which means nothing other than unifying, which is, if one may also say it, the common term of all the categorical functions, the common term which is ordered and is decomposed in the very suggestive articulated table that Kant gives of it or rather in the two tables that he gives of it: the forms of the categories and the forms of judgement, which grasps that by right, in so far as it marks the spontaneity of the subject in the relationship to reality, this pure intuition is absolutely required.

One could manage to reduce the Kantian schema to Beharrlichkeit, to permanence, to the holding, which I would describe as empty,

but the possible holding of anything whatsoever in time. This intuition which is pure by right is absolutely required by Kant for the functioning of the categories, but after all that the existence of a body, in so far as it is the foundation of sensoriality - Sinnlichkeit - is not required at all, no doubt, for what one can validly articulate as a relationship to reality, this will take us no further since, as Kant underlines, the use of these categories of understanding will only concern what he is going to call empty concepts; but when we say that this will take us no further, it is because we are philosophers, and even Kantians, but once we no longer are that, which is the most common case, everyone knows precisely that on the contrary this goes very far because the whole effort of philosophy consists in countering a whole series of illusions, of Schwärmereien as it is expressed in "philosophique" and particularly Kantian language; bad dreams - at the same epoch Goya tells us: "the sleep of (9) reason engenders monsters" - whose theologising effects indeed show us quite the contrary, namely that this goes very far, since through the mediation of a thousand fanaticisms this leads quite simply to bloody violence, which continues moreover quite tranquilly, despite the presence of philosophers to constitute, it has to be said, an important part of the texture of human history.

It is for that reason that it is not at all indifferent to show where there passes in effective the frontier of what is effective in experience despite all the theoretical purifications and the moral rectifications. It is quite clear in any case that there is no way of admitting Kant's "Transcendental aesthetic" as tenable despite what I called the unsurpassable character of the service that he renders us in his critique, and I hope to make you sense it precisely from what I am going to show you it would be well to substitute for it. Because precisely if it would be well to substitute something for it and if this functions while preserving something of the structure that he articulated, this is what proves that he at least glimpsed, that he profoundly glimpsed this very thing. Thus it is that the Kantian aesthetic is absolutely not tenable, for the simple reason that for him it is fundamentally supported by a mathematical argumentation which belongs to what one could call the geometrizing epoch of mathematics. It is in so far as Euclidian geometry is uncontested at the time Kant was pursuing his meditation, that it is sustainable for him that there are in the spatio-temporal order certain intuitive facts. One has only to bend down, to open his text, to collect examples of what may appear now (10) immediately refutable to a student averagely advanced in a mathematical initiation, when he gives us as an example of a fact which does not even need to be demonstrated, that only one straight line can pass between two points. Everyone knows, in so far as the mind has in sum adapted itself rather easily to the imagination, to the pure intuition of a curved space through the metaphor of this sphere, that through two points, there can pass many more than one straight line, and even an infinity of straight lines. When he gives us in this table of nichts, of nothings, as example of the leere Gegenstand ohne Begriff: of the empty object without a concept, the following example which is

rather extraordinary: the illustration of a rectilinear figure which would only have two sides, here is something which might seem to Kant - and no doubt not to everyone at his epoch - as the very example of the inexistent object and what is more the unthinkable one; but the least usage I would say even of the quite elementary experience of a geometer, the investigation of the trace described by a point linked to the circumference of a circle, what is called a Pascalian cycloid, will show you that a rectilinear figure, in so far as it properly puts in question the permanence of the contact between two lines and two sides is something which is truly primordial, essential to any kind of geometrical comprehension, that there is well and truly here a conceptual articulation and even a quite definable object.

Moreover, even with this affirmation that nothing except the synthetic judgement is fruitful, it may still, after the whole effort of logicising mathematics, be considered as subject to (11) reason. The so-called unfruitfulness of the a priori analytic judgement, namely of what we will call quite simply the purely combinatory usage of elements extracted from the primary position of a certain number of definitions, that this combinatory usage has in itself its own fecundity, this is what the most recent, the most advanced critique of the foundations of arithmetic, for example, can certainly demonstrate. That there is in the final analysis, in the field of mathematical creation, a necessarily undemonstrable residue, this is what no doubt the same logicising exploration seems to have led us to (Godel's theorem) with a rigour unrefuted up to now, but it remains nonetheless that it is by way of formal demonstration that this certainty can be acquired and, when I say formal, I mean by the most expressly formalist procedures of logicising combination.

What does that mean? Is it that for all that this pure intuition, as for Kant at the end of a critical progress concerning the required forms of science, that this pure intuition teaches us nothing? It undoubtedly teaches us to discern its consistency with and also its possible disjunction from precisely the synthetic exercise of the unifying function of the term of unity qua constitutive in every categorical formation and, once the ambiguities of this function of unity have been shown, of showing us to what choice, to what reversal we are led under the influence of diverse experiences.

(12) Here obviously it is only our own which is important. But is it not more significant than anecdotes, accidents, even exploits, to the precise point that one can point out the slenderness of the point of conjunction between the functioning of the categories and sensible experience in Kant, the strangling point as I might say, at which there can be raised the question of whether the existence of a body, altogether required of course, could not in fact be put in question in the Kantian perspective. As regards the fact that it is required by right, is there something which has not at all been done?

In order to presentify for you this question in the situation of this lost child that the cosmonaut of our epoch in his capsule is

in when he is in a state of weightlessness, I will not put any weight on this remark that the tolerance of it, it seems, has of course not yet been put to the test for very long. But all the same the surprising tolerance of the organism of the weightless state is all the same likely to make us pose a question, since after all dreamers question themselves about the origin of life - and among them there are those who say that this suddenly began to fructify on our globe, but others say that it must have come through a germ which came from the astral spaces. I cannot tell you how indifferent this sort of speculation leaves me. All the same, from the moment that an organism, whether it is human, whether it is that of a cat or of the least lord of the living kingdom, seems so happy in the state of weightlessness, is it not precisely essential for life let us simply say that it should be in an equipollent position with respect to any possible effect of (13) the field of gravity? Of course, the cosmonaut is always subject to the effects of gravity; simply it is a gravity which does not weigh on him. Well then, there where he is in his weightless state, locked in as you know in his capsule and what is more again sustained, moltonne from all sides by the folds of this capsule, what does he transport with him in terms of an intuition which is pure or not, but phenomenologically definable, of space and of time? The question is all the more interesting because you know that since Kant we have all the same gone back on that. I mean that the exploration qualified precisely as phenomenological has all the same brought our attention back to the fact that what one can call the naive dimensions of specifically spatial intuition, are not all the same an intuition, however purified one may think it, that is so easily reducible and that the top, the bottom, indeed the left preserve all their importance not alone in fact, but even by right for the most critical thinking.

What happened to Gagarin or to Titov or to Glenn, in terms of their intuition of space and of time in the moments when certainly they had, as one says, other things on their minds? It would not perhaps be altogether uninteresting to have a little phenomenological dialogue with one of them while he is up there. In these experiments, naturally it was considered that this was not the most urgent thing to do. Besides, there is time to return to it. What I am affirming, is that, whatever may be the case about these points on which we all the same are rather eager to have answers from Erfahrung, from experience, this in any case (14) did not prevent him from being quite capable of what I would call pressing the buttons, because it is clear, at least for the last one, that the business was commanded at one or other moment and even decided from inside. He remained therefore in full possession of the means of an effective combination. No doubt his pure reason was powerfully equipped with a whole complex arrangement which undoubtedly gave its final efficacy to the experiment. It nevertheless remains that, as regards everything that we can suppose, and as far as we can suppose, to be the effect of the combinatory construction in the apparatus, and even in the learning experiences, in the repeated tasks in the exhausting formation imposed on the pilot himself, to the extent that we could suppose him to be integrated to what one could call

the already constructed automatism of the machine, it is enough that he should have to push a button in the right direction while knowing why, for it to become extraordinarily significant that such an exercise of combining reason is possible in conditions which perhaps are far from still being the extremes reached of the constraint and paradox we can suppose imposed on the conditions of natural motor functions, and that correlatively, things only function in so far as the aforesaid motor subject is literally imprisoned by the carapace which alone guarantees the containment, at least at one or other moment of the flight, of the organism in what one could call its elementary solidarity.

(15) Here therefore this body has become as I might say a sort of mollusc, but torn away from its vegetative implantation. This carapace becomes such a dominant guarantee of the maintenance of this solidarity, of this unity, that one is not far from grasping that it is in it in the final analysis that it consists, that one sees there in a sort of exteriorized relationship of the function of this unity as a veritable container of what one can call the living pulp. The contrast between this corporal position and this pure function of reasoning machine, this pure reason which remains the only efficacious thing and everything from which we await some efficaciousness or other within, is indeed here something exemplary which gives all its importance to the question that I posed earlier about the preservation or not of spatio-temporal intuition, in the sense that I sufficiently supported it by what I would call the false geometry of Kant's time. Is this intuition still there? I have a strong tendency to think that it is still there.

This false geometry is still there, just as stupid and just as idiotic, because it is effectively produced as a sort of reflection of the combining activity, but a reflection which is no less refutable. Because as the experience of the meditation of mathematicians has proved, on this earth, we are no less liberated from weight than in the place above where we follow our cosmonaut. In other words that this so called pure intuition has come from the illusion of the lures attached to the combinatory function, itself quite possible to dissipate even if it proves to be more or less tenacious, it is no more, as I might say, than the shadow of a shadow.

(16) But of course, to be able to affirm that, it is necessary to have based number itself elsewhere than in this intuition. Besides, if we suppose that our cosmonaut does not preserve this Euclidean intuition of space, and the still much more questionable one of time which is appended to it in Kant, namely something which can be projected onto a line, what would that prove? That would simply prove that he is all the same capable of correctly pushing the buttons without having recourse to their schematism, this would simply prove that what is already refutable here is refuted up there in intuition itself, which, you will tell me, reduces perhaps a little the import of the question that we have to pose to him.

And this indeed is the reason why there are other more important

questions to pose to him, which are precisely ours, and particularly this one: what becomes in the weightless state of a sexual drive which is used to manifesting itself by appearing to go against, and whether the fact that he is entirely stuck inside a machine - I mean in the material sense of the word - which incarnates, manifests in such an obvious fashion the phallic phantasy, does not particularly alienate him from its relationship to the functions of weightlessness natural to male desire. Here is another question that we have quite legitimately I believe to stick our nose into.

To come back to number, which it may astonish you that I make into an element so obviously detached from pure intuition, from sense experience I am not going to give you a seminar here on the Foundations of arithmetic the English title of Frege to which I (17) would ask you to refer because it is a book as fascinating as the Martian chronicles and you will see that it is in any case obvious that there is no empirical deduction possible of the function of number, but as regards which, since I have no intention of giving you a lecture on this subject, I will content myself, because it is part of our account, with pointing out to you that for example the five points arranged in this way that



you can see on the face of a dice, is indeed a figure which can symbolise the number five but that you would be completely wrong to believe that the number five is given to you in any way by this figure. As I do not want to weary you by making an infinite number of detours, I think that the quickest way is to make you imagine a behavioural experiment that you might be in the process of carrying out on an animal.

It is rather frequent, in order to experiment with this faculty of discernment that the animal has, in one or other situation made up of goals to be reached, for you to give him different shapes. Suppose that alongside this arrangement, something which constitutes a figure, you would not expect in any case and from any animal that he should react in the same fashion to the following figure, which is nevertheless also a five, or to this one which is no less one, namely the form of a pentagon (schema):



If an animal were ever to react in the same fashion to these three figures, well you would be stupified, and very precisely for the reason that you would then be absolutely convinced that the animal knows how to count. But, you know that he does not know how to count. This is not a proof of the non-empirical origin of the function of number. I tell you again: this merits (18) a detailed discussion regarding which after all the only true, sensible, serious reason that I have to strongly advise you

to interest yourselves in it, is that it is surprising to see the degree to which few mathematicians, even though it is not only mathematicians who have treated it properly, really interest themselves in it. It will therefore be on your part, if you interest yourselves in it, a work of mercy: to visit the sick, to interest oneself in uninteresting questions, is this not also in some way our function? You will see in it that in any case unity and zero, so important for every rational constitution of number, are what are the most resistant, of course, to every attempt at an experimental genesis of number, and most especially if one intends to give a homogenous definition of number as such, reducing to nothing all the geneses that one may try to give of number starting from a collection and from the abstraction of difference starting from diversity. Here the fact that I was led, directly along the line of the Freudian approach, to articulate in a fashion which appeared necessary to me the function of the unary trait takes on its value, in so far as it makes the genesis of difference appear in an operation that one can say is situated along the line of an ever increasing simplification, that it is in a perspective which is the one which culminates at the line of strokes, namely with the repetition of the apparently identical that there is created, separated out, what I call, not the symbol, but the entry into the real as inscribed signifier - and this is what the term of primacy means - of writing. The entry into the real, is the form of this trait repeated by the primitive hunter of absolute difference in so far as it is there.

(19) Moreover you will have no trouble - you will find them in reading Frege, even though Frege does not take that path, for want of an adequate theory of the signifier - in finding in Frege's text that the best mathematical analysts of the function of unity, specifically Givon and Schroder, put the accent in the same way as I am doing it, on the function of the unary trait.

This is what makes me say that what we have to articulate here, is that by reversing, as I might say, the polarity of this function of unity, by abandoning the unifying unity, the Einheit, for the distinctive unity, the Einzigkeit, I am leading you to the point of posing the question, of defining, of articulating step by step the solidarity of the status of the subject qua bound to this unary trait with the fact that the subject is constituted in his structure where the sexual drive has its privileged function among all the afferents of the body. To the first fact, the liaison of the subject to this unary trait, I am going today to put the final point, considering the path to be sufficiently articulated by reminding you that this fact so important in our experience, put in the forefront by Freud, of what he calls the narcissism of small differences, is the same thing as what I am calling the function of the unary trait; because it is nothing other than the fact that it is starting from a small difference - and to say small difference means nothing other than this absolute difference of which I speak to you, this difference detached from all possible comparison - it is starting from this small difference, in so far as it is the same thing as the big I, the ego-ideal, that every narcissistic

perspective can be accommodated; the subject constituted or not (20) as bearer of this unary trait, is what allows us to take today our first step into what will constitute the object of our next lecture, namely the taking up again of the functions of privation, frustration, castration.

It is first of all by taking them up again that we will be able to glimpse where and how there is posed the question of the relationship between the world of the signifier and what we call the sexual drive, namely the privilege, the prevalence of the erotic function of the body in the constitution of the subject. Let us tackle it a little bit, let us nibble at it, this question, starting from privation, because it is the most simple. Something of minus 0 exists in the world, there is an object which is not in its place, which is indeed the most absurd conception of the world if one gives its meaning to the word Real. What could be lacking in the Real?

Moreover it is because of the difficulty of this question that you still see, in Kant, remaining, as I might say, well beyond therefore pure intuition, all these old remainders which shackle him with theology, and under the name of a cosmological conception, "In mundo non est casus", he reminds us: there is nothing casual, occasional. "In mundo non est fatum": there is no fatality which goes beyond a rational necessity; "In mundo non est fatum": there are no leaps: "In mundo non est hiatus", and the great refutor of metaphysical imprudences makes his own these four denegations, about which I ask you, whether in our perspective, they can appear to be anything other than the very inverted status of what we always have to deal with in cases, in the proper sense of the term, with a fatum properly speaking, (21) because our unconscious is an oracle, with as many hiatuses as there are distinct signifiers, as many jumps as there are metonymies produced. It is because there is a subject who is himself marked or not by a unary trait who is one or minus one, that there can be a minus 0, that the subject can identify himself with the little ball of Freud's grandson and especially in the connotation of its lack: there is not, ens privativum. Of course, there is a void and it is from there that the subject is going to start: leere Gegenstand ohne Begriff.

Of the four definitions of nothing that Kant gives and that we will take up the next time, it is the only one that holds up rigorously: here there is a nothing. Observe that in the table that I gave you in three terms, castration, frustration, privation, the counterpart, the possible agent, the properly speaking imaginary subject from whom privation the enunciating of privation can flow, is the subject of imaginary omnipotence, namely of the inverted image of impotence. Ens rationis: leere Begriff ohne Gegenstand, pure concept of possibility. Here is the framework in which there is situated and there appears the ens privativum. Kant of course does not fail to ironise about the purely formal usage of the formula which seems to be self-evident: everything real is possible. Who will contradict that? Obviously. And he takes the further step by pointing out to us that: therefore some real is possible, but that can also

mean that some possible thing is not real, that there is something possible which is not real; no less of course the philosophical abuse which can be made of it is here enounced by Kant. What is important for us is to grasp that the possible (22) involved is not the possible of the subject. The subject alone can be this negated real of a possible which is not real. We thus see the minus 1 constitutive of the ens privativum linked to the most primitive structure of our experience of the unconscious, in so far as it is not that of prohibition, nor of saying not, but of the unsaid (du non-dit), of the point where the subject is no longer there to say whether he is no longer master of this identification to the 1, or of this sudden absence of the 1 which, you will remark, here finds its force and its root; the possibility of fatum, casus, saltus, is precisely the way in which I hope beginning from the next session to show you what other form of pure and even spatial erudition is especially involved in the function of surface. In so far as I believe it to be capital, primordial, essential, for any articulation of the subject that we can formulate.

Seminar 12: Wednesday 7 March 1962

In regrouping the difficult thoughts to which we are led, on which I left you the last time, in beginning to tackle by way of privation what concerns the most central point of the structure of the identification of the subject, in regrouping these thoughts I found myself starting again from some introductory remarks.

It is not my custom to take up the interrupted thread again absolutely ex abrupto; these remarks echoed some of these strange personages of whom I spoke to you the last time, who are called philosophers, great or small, this remark was more or less the following, as far as we are concerned, the fact that the subject is mistaken (se trompe), is undoubtedly for us, analysts just as much as philosophers, the inaugural experience.

But the fact that it interests us, is manifestly and I would say exclusively because he can express himself (il peut se dire), and this expression shows itself to be infinitely fruitful and more especially fruitful in analysis than elsewhere, at least one likes to think so.

But, let us not forget that the remark has been made by eminent thinkers that if what is involved in the affair is the real, the way described as that of the rectification of the means of (2) knowing could well - it is the least that one might say - distance us indefinitely from what it is a question of reaching, namely something of the absolute. Because it is a matter of the real, full stop, that is what is involved. It is a matter of reaching what is aimed at as independent of all our moorings; in the search for what is aimed at this is what is called absolute: in the end to cast off everything. All overloading therefore, it is always a more overloaded way that the criteria of science tends to establish, in the philosophical perspective that I am talking about. I am not speaking here about these learned men, who for their part, contrary to what is believed, have no doubts.

It is in this measure that we are more sure that at least they approach the real.

In the philosophical perspective of the critique of science, we ought, for our part, to make some remarks; and specifically the term that we should most distrust in order to advance in this critique, is the term appearance, because appearance is far from being our enemy, I am talking about when it is a matter of the

real. I am not the one who incarnated what I am telling you in this simple little image: It is indeed in the appearance of this figure that there is given to me the reality of the cube, that it stands out for me as a reality.

To reduce this image to the function of an optical illusion, would simply divert me from the cube, namely from the reality that this artifice is meant to show you.

(3) It is the same for a relationship with a woman, for example. Every scientific investigation of this relationship will tend when all is said and done towards formulae like the celebrated one that you surely know of Colonel Bramble, which reduces the object involved, the woman in question, to what she simply is from the scientific point of view: an agglomeration of albumins, which obviously does not agree very well with the world of feelings which are attached to the aforesaid object.

It is all the same quite clear that what I would call, if you will permit it, the dizziness about the object in desire, this kind of idol, of adoration which can prostrate us or at least weaken us before a hand as such. Let us even say, in order to make ourselves better understood about the subject given us in experience, that it is not because it is her hand because in a less terminal place, a little higher up, a little down on the forearm can suddenly take on for us this unique savour which makes us in some way tremble before this pure apprehension of her existence.

It is quite obvious that this has a greater relationship to the reality of the woman than any elucidation whatsoever of what is called sexual attraction, in so far of course as elucidating sexual attraction poses in principle that it is a matter of putting in question its lure, while this lure is its very reality.

Therefore, if the subject is mistaken, he may well be right from the point of view of the absolute. It nevertheless remains, and (4) even for us who busy ourselves with desire, that the word error keeps its meaning.

Here allow me to tell you how I for my part conclude, namely to give you as completed the fruit of a reflection on this matter whose continuation is precisely what I am going to advance today. I am going to try to show you its well-foundedness, the fact is that it is not possible to give a meaning to this term of error, in any domain and not just in ours - this is a daring affirmation, but this supposes that I consider that, to use an expression to which I will have to return in the course of my lecture today, I have gone into this question thoroughly - there can be no question, if the word error has a meaning for the subject, of anything but an error in his count.

In other words, for any subject who does not count, there can be no error. This is not obvious. It is necessary to have explored a certain number of directions in order to perceive and

to believe - this is where I am at and I would ask you to follow me - that this is the only thing that opens up the impasses, the blind alleys into which people have gone about this question.

This means of course that this activity of counting begins early for the subject. I carried out a full rereading of someone for whom everyone knows I do not have very refined leanings despite the great esteem and respect that his work merits and in addition his uncontestable charm as a person, I am speaking about M Piaget; this is not to discourage anyone from reading him!

(5) I carried out then a re-reading of The genesis of number in the child. It is disconcerting that someone can believe themselves able to detect the moment that there appears in the subject the function of number by posing him questions which in a way imply their response, even if these questions are posed through the mediation of a material which one imagines perhaps excludes the biased character of the question. One thing can be said: that when all is said and done it is rather a lure that is involved in this way of proceeding. It is not at all sure that what the infant appears to misconceive does not depend at all on the very conditions of the experiment; but the strength of this terrain is such that one cannot say that there is not a lot to be learned, not so much in the little bit which is finally collected about the so-called stages of the acquisition of number in the child, but from the fundamental reflections that M Piaget who is certainly a much better logician than psychologist, concerning the relationships of psychology and of logic; and specifically this is what makes a work which unfortunately is unfindable, published by Vrin in 1942 which is called: Classe, relation et nombres, a very instructive work because here there are highlighted the structural, logical relationships between class, relation and numbers, namely everything that one claims subsequently or previously to rediscover in the child which manifestly is already constructed a priori: and very correctly, the experiment only shows us there what one had organised it to find in the first place.

(6) This is a parenthesis confirming the following: the fact is that the subject counts well before applying his talents to any collection whatsoever, even though of course, to establish collections is one of the first concrete, psychological activities. But he is implicated as subject in what is called the relationship of computation, in a fashion much more radically constituting than people want to imagine, starting from the functioning of his sensorium and his motor functions.

Once again here the genius of Freud surpasses what I might call the deafness of those to whom he is addressing himself in the exact measure of the warnings that he gives them, which go in one ear and out the other, this justifying no doubt the appeal to the mystical third ear of Mr Theodore Reik who was not very well inspired that day, because what use is a third ear if one hears nothing with the two one has already!

Of what use is the sensorium involved, according to what Freud

teaches us? Does this not tell us that its only use is this, to show us that what is already there in the calculation of the subject is quite real, really exists; in any case this is what Freud says: it is with it that the judgement of existence begins, this is used to audit the accounts, which is all the same a funny position for someone whom people attach to this straight line of the positivism of the 19th century.

(7) So, let us take things up where we left them, because it is a matter of calculation, and of the basis and foundation of calculation for the subject: because of course if the unary trait begins the function of counting so early, let us not go too quickly as regards what a subject may know about a higher number. It is difficult to imagine that two and three do not come rather quickly. But when we are told that certain so-called primitive tribes along the mouth of the Amazon were only recently able to discover the virtue of the number four and raised altars to it, it is not the picturesque aspect of this story about savages which strikes me: this seems to me to be self-evident, because if the unary trait is what I am telling you, namely the difference and the difference, which not alone supports, but which supposes the subsistence alongside it of one plus one and one again, the plus being only meant there to mark well the radical subsistence of this difference, where the problem begins is precisely that one can add them together, in other words that two, that three have a meaning. Taken from that angle this causes a lot of trouble; but one must not be astonished at it. If you take things in the opposite direction, namely if you begin from three, as John Stuart Mill did, you will never manage to rediscover one, the difficulty is the same.

For us here - I point it out to you in passing - with our way of interrogating the facts of language in terms of the effects of the signifier, in so far as we are used to recognising this effect of the signifier at the level of metonymy, it would be simpler for us than for a mathematician to ask our pupil to recognise in every signification of number an effect of metonymy (8) which has arisen virtually from nothing more and, as its elective point, from the succession of an equal number of signifiers. It is in so far as something is happening which makes sense of the simple sequence of extension x of a certain number of unary traits, that the number three for example can make sense, namely that it makes sense - whether it has any or not - to write the word end in English: here again perhaps is the best way we have of showing the emergence of the number three because there are three letters.

As for us we have no need to demand so much of our unary trait; because we know that at the level of the Freudian series, if you will allow me this formula, the unary trait designates something which is radical for this originating experience: it is the unicity as such of the circuit (tour) in repetition.

I think I have sufficiently stressed for you that the notion of the function of repetition in the unconscious is absolutely distinguished from any natural cycle, in the sense that what is

accentuated is not its return, it is that what is sought by the subject is its signifying unicity and in so far as one of the circuits of the repetition, as one might say, has marked the subject who begins to repeat what of course he will only be able to repeat because this will never be anything but a repetition, but with the goal, the plan, of making the original unary re-emerge from one of its circuits.

With what I have just told you, I have no need to put the accent on the following: the fact is that this operates already before (9) the subject knows how to count properly. In any case, nothing implies that he has a need to count the circuits of what he is repeating very far because he repeats it without knowing it. It is no less true that the fact of repetition is rooted in this original unary, which unary as such is tightly coupled to and co-extensive with the very structure of the subject in so far as it is thought of as repeating in the Freudian sense.

What I am going to show you today, through an example, and with a model that I am going to introduce, what I am going to show you today, is the following: it is that there is no need for him to know how to count for one to be able to say and demonstrate the constituting necessity of his function as subject that he should make an error in the count. There is no need for him to know nor even to try to count for this error of counting to be constitutive of him as subject: as such it is error.

If things are as I am telling you, you can be sure that this error may last a long time on such a basis, and this is quite true. It is so true that it is not alone on the individual that it brings its effect to bear. It brings its effect to bear on the most radical characters of what is called Thinking.

Let us take for a moment the theme of Thinking, about which it would be proper all the same to use some prudence; you know that on this point I do not lack it, it is not all that sure that one can validly refer to it in a fashion which may be considered as a (10) properly speaking generic dimension. Let us take it nevertheless as such: the thinking of the human species.

It is quite clear that it is not for nothing that I have advanced more than once, in an inevitable fashion, towards putting in question here, since the beginning of my discourse this year, the function of class and its relationship with the universal, to the point even that it is in a way the reverse and the opposite of all this discourse that I am trying to bring to a conclusion before you.

In this connection, simply remember what I was trying to show you in connection with the little exemplary dial on which I tried to re-articulate before you the relationship of the universal to the particular and of affirmative and negative propositions respectively. Unity and totality appear here in the tradition as solidary, and it is not by chance that I always come back to it in order to shatter the fundamental category: unity and totality at once solidary, linked to the other in this relationship that

one could call a relationship of inclusion, totality being totality with respect to units, but unity being what founds totality as such by drawing unity towards another meaning, opposed to the one that I distinguish of it, of being the unity of a whole. It is around this that there is pursued this misunderstanding in what is called the logic of classes, this age-old misunderstanding of extension and intension which it seems tradition effectively has always made more of, even if it is true, taking things in the perspective for example of the middle of the XIXth century, in the writings of a Hamilton, even if it is true that it has only been clearly articulated from (11) Descartes on and that the logic of Port-Royal, as you know, is modelled on the teaching of Descartes. What is more this is not true; because this opposition between extension and comprehension is there for a long time, since Aristotle himself. What one can say, is that it causes for us, as regards the handling of classes, difficulties which are always more unresolved, hence all the efforts that logic has made to transport the core of the problem elsewhere: into propositional quantification for example.

But why not see that in the structure of class itself as such a new beginning is presented to us, if, for the relationship of inclusion, we substitute a relationship of exclusion as the radical support? In other words, if we consider as logically original as regards the subject something that I am not discovering, which is within the range of an average logician, the fact is that the true foundation of class is neither its extension nor its intension, that class always supposes classification. In other words: mammals, for example to throw some light immediately on what I mean are what are excluded from vertebrates by the unary trait "mamma".

What does that mean? That means that the primal fact is that the unary trait can be lacking, that there is first of all the absence of the mamma and that one says: it cannot be that the mamma is missing, here is what constitutes the mammal class.

Look carefully at things when you really push them, namely open the treatises and go through these thousand little aporias that formal logic puts before you and you will see that it is the only (12) possible definition of a class, if you really want to guarantee it its universal status in so far as it constitutes also from one side the possibility of its possible inexistence with this class. For you can just as validly, lacking from the universal, define the class which includes no individual, this will be nonetheless a class universally constituted with the conciliation I am saying, of this extreme possibility with the normative value of every universal judgement in so far as it cannot but transcend every inductive inference namely drawn from experience.

This is the meaning of the little dial that I represented for you in connection with the class to be constituted among the others, namely the vertical trait.

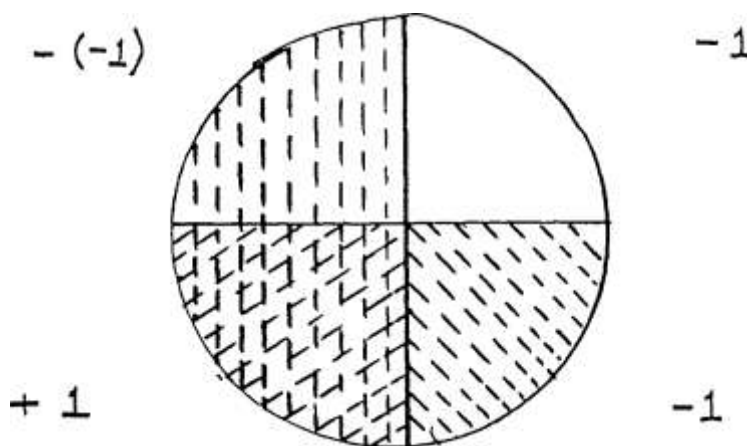

The subject at first constitutes the absence of such traits, as such he is himself the top quarter on the right. The zoologist if you will allow me to go this far, does not carve out the mammal class in the assumed totality of the maternal mamma; it is because he detaches the mamma that he can identify the absence of mamma. The subject as such is minus one. It is starting from (13) there, from the unary trait qua excluded that he decrees that there is a class in which universally there cannot be the absence of the mamma: minus minus one: $-(-1)$. And it is starting from there that everything is specifically ordered in particular cases: in anything whatsoever (le tout venant), there is one or there is not one (2 - 3). A contradictory opposition is established diagonally, and this is the only true contradiction which subsists at the level of the establishment of the universal/ affirmative, particular/negative dialectic, by the unary trait.

Everything is ordered therefore in anything whatsoever at the lower level, there is some of it or there is none of it, and this cannot exist except in so far as there is constituted, by the exclusion of the trait, the stage of anything whatsoever or of what is valid like everything at the upper level.

It is therefore the subject, as one might have expected, who introduces privation and this by the act of enunciating which is essentially formulated as follows: "could it be that there is no mamma?" (qu'il n'y ait), ne which is not negative, ne which is strictly of the same nature as what one can call the expletive in French grammar - "could it be that there is no mamma? Not possible, nothing maybe". Here we have the beginning of every enunciating of the subject concerning the real.

In the first blank of the circle it is a question of preserving the rights of the nothing, on top, because it is what creates below the perhaps, namely the possibility. Far from being able (14) to say as an axiom - and this is the stupefying error of the whole abstract deduction of the transcendental - far from being able to say that anything real is possible, it is only starting from the not possible that the real takes its place.

What the subject is looking for is this real qua precisely not possible; it is the exception and this real exists of course. What one can say, is that there is precisely not only the not possible at the origin of any enunciating. But this can be seen from the fact that it is from the enunciation of the nothing that it begins. This in a word is already guaranteed, clarified, in my triple enumeration: privation, frustration, castration as I announced we would be developing it the other day, and some people are upset because I am not providing a place for the Verwerfung: it is there beforehand, but it is impossible to start from it in a deducible fashion. To say that the subject is first of all established as minus one, is indeed something in which you can see that effectively, as one might expect, it is as Verworfen that we are going to rediscover him, but in order to grasp that this is true, we are going to have to make an enormous circuit. This is what I am going to try to initiate now.

In order to do it, I must unveil the battery I announced - and you may well imagine that I tremble a little at this - and that I bring out for you one of my turns which has of course been prepared for a long time. I mean that if you look in the Rome report you will already find its place highlighted somewhere. I speak about the structure of the subject as that of a ring. Later on, I mean last year and in connection with Plato - and (8) still as you see it is not unrelated to what I am debating for the moment, namely the inclusive class - you have seen all the reservations that I believed I had to introduce in connection with the different myths of the Symposium, so intimately linked to Platonic thinking concerning the function of the sphere.

The sphere, this obtuse object, as I might say: you only have to look at it to see it. It is perhaps a good shape, but it really is stupid! It is cosmological of course. Nature is supposed to show us a lot of it, not so much as all that when one looks closely at it; and the ones that it shows us, we hold onto. For example: the moon which nevertheless would be much better used, if we were to take it as an example of a unary object. But let us leave this to one side.

This nostalgia for this sphere which with a phonuscule makes us drag on in biology itself this metaphor of the Innen and Umwelt, this is what is supposed to constitute the organism.

Is it altogether satisfying to think that in order to define the organism we have to satisfy ourselves about the correspondence, about the fitting together of this innen and this urn? No doubt there is here a profound view; because it is indeed here in effect that the problems lies, and already simply at the level at which we are, which is not that of the biologist but of the analyst of the subject.

What is the Welt doing here? This is what I am asking. In any (16) case, because it is necessary that here in passing we should acquit ourselves of some homage or other to the biologists, I would ask why, if it is true that the spherical image is to be considered as radical, it should then asked why this blastula is

not satisfied until it has been gastrulated and having been gastrulated it is not content until it has redoubled its stomach orifice with another, namely a hole in the backside. And why also at a certain stage of the nervous system it presents itself as a tube, open at both ends to the outside; no doubt this closes itself off, it is even very well closed off but this, as you are going to see, should not discourage us at all, because I am going to abandon right away this path which is described as that of Naturwissenschaft.

This is not what interests me now and I am quite determined to transport the question elsewhere, even if by that I may appear to you to be putting myself, one may as well say it, in the wrong (dans mon tore)!

Because the torus is what I am going to speak to you about today. From today on, as you will see, I am deliberately opening up the era of presentiments. For a certain time I would like to envisage things under the double aspect of rightly and wrongly (a tort et a raison), and many others again which are offered to you.

Let us try now to clarify what I am going to tell you.

A torus - I think that you know what it is - I am going to make a (17) rough figure of it for you; it is something that one plays with when it is made of rubber, it is handy, a torus can be deformed, it is round, it is full, for the geometer it is a figure of revolution engendered by revolving a circumference around an axis situated on its plane; the circumference turns; at the end you are surrounded by the torus, I even believe that that is called a hula hoop.

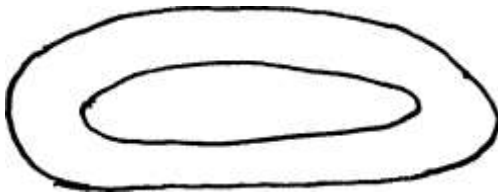

What I would like to underline is that here this torus, I am speaking in the strict geometrical sense of the term, namely that according to the geometrical definition it is a surface of revolution, it is the surface of revolution of this circle around an axis and what is generated is a closed surface.

This is important because this rejoins something that I announced to you in a special lecture outside the series that I am giving you here but to which I have referred since, namely the accent that I intend to put on the surface in the function of the subject.

In our time, it is fashionable to envisage a whole lot of spaces with a multitude of dimensions. I ought to tell you that, from

the point of view of mathematical reflection, this demands that one should not unreservedly believe in it.

(18) Philosophers, the good ones, those who leave behind them a good smell of chalk like M Alain, will tell you that even the third dimension, well then, it is quite clear that from the point of view that I was putting forward earlier about the real, is quite suspect. In any case for the subject two are enough, believe me.

This explains for you my reservations about the term "depth psychology" and will not prevent us from giving a meaning to this term.

In any case for the subject as I am going to define it for you, you can be sure that this infinitely flat being which gave, I am sure, such joy to your mathematics classes when you were in philosophy: "The infinitely flat subject¹¹" said the professor, since the class was rowdy and since I was too, one did not hear everything; it is here, then, it is here that we are going to advance into this infinitely flat subject in the way that we conceive of it, if we wish to give its true value to the fact of identification as Freud promotes it for us. And as you will see, this again will have a lot of advantages.

Because, after all, if it is expressly to the surface that I here ask you to refer yourselves, it is for the topological properties that it is going to be able to demonstrate to you.

It is a good surface, as you see, because it preserves, I would (19) say necessarily, it could not be the surface it is if it did not have an inside. As a result, reassure yourselves, I am not taking you away from volume, nor from what is solid, nor from this complement of space of which you surely have need in order to breathe. Simply I am asking you to notice that if you do not prohibit yourself from entering into this inside, if you do not consider that my model is designed to be of service only at the level of the properties of the surface, you are going, as I might say, to lose all its savour, because the advantage of this surface depends entirely on what I am going to show you about its topology, because of the original thing that it contributes from a topological point of view compared for example to the sphere or the plane; and if you start weaving things on the inside, by drawing lines from one side to the other of this surface, I mean even though it has the appearance of being opposed to itself you are going to lose all its topological properties.

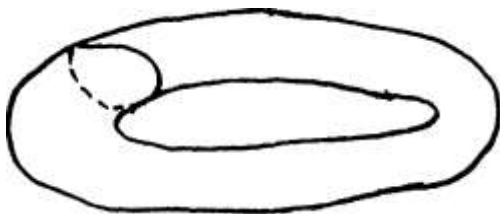

You are going to see the core, the spice, the savour of these topological properties. They consist essentially in a support-word that I allowed myself to introduce in the form of a riddle at the lecture of which I spoke earlier; and this word which could not have appeared to you at that time with its real meaning, is the loop (lacs).

You see that in the measure that advances are made I reign over my words for some time. I deafened your ears for a while with (20) lacuna, now lacuna is reduced to lacs.

The torus has this considerable advantage over a surface, which is nevertheless a good one to savour which is called the sphere or quite simply the plane, of not being at all Umwelt with respect to the loops whatever they may be - lacs is lakis - that you may trace on its surface.

In other words, on a torus as on any other surface you can make a little ring; and then as they say, by progressive shrinkages you reduce it to nothing, to a point. Observe that whatever may be the loop that you situate in this way on a plane or on the surface of a sphere it will always be possible to reduce it to a point; and if it is the case, as Kant tells us, that there is a transcendental aesthetic, I believe in it: simply I believe that his is not the right one because precisely it is the transcendental aesthetic of a space which first of all is not one, and in the second place where everything depends on the possibility of the reduction of anything whatsoever that is traced on the surface which characterises this aesthetic so that it can be reduced to a point, so that the totality of inclusion which defines a circle can be reduced to the vanishing unity of any point whatsoever around which it gathers itself, of a world whose aesthetic is such that everything can be folded back on everything, one always believes that one can have the all in the hollow of one's hand; in other words that whatever one draws on it, one is able to produce in it this sort of collapse which when (21) significance is involved will be called tautology. Everything entering into everything, consequently the problem is posed: how it can happen that with purely analytic constructions one can manage to develop an edifice which rivals the real as well as mathematics?

I am proposing that one should admit in a fashion which no doubt involves a concealment, something hidden which is going to have to be carried forward, rediscovered where it is, one should pose that there is a topological structure regarding which it is going to be a question of showing how it is necessarily that of the subject, which means that there are certain of its loops which cannot be reduced. This is the whole interest of the model of my torus.

The fact is, as you can see, just by looking at it, there are a certain number of circles traceable on this torus; this one, in so far as it closes on itself I would call, it is simply a question of a name, a full circle. No hypothesis about its inside, it is a simple tag which I believe, by God, no worse than

any other, taking everything into consideration. I wavered for a long time in speaking about it with my son - why not name him. One might call it the engendering circle, but God knows where that would lead us!

But let us suppose therefore that any enunciating of the methods which are called synthetic - because one is surprised especially by this: even though one can enounce them a priori, they seem, one does not know where, one does not know what, to contain something, and this is what is called intuition, and one seeks out its aesthetic, transcendental foundation - let us suppose therefore that every synthetic enunciating - there are a certain number of them at the origin of the subject, and to constitute it - well then, unfolds according to one of these circles, called the full circle and this is what images best for us what in the completion of this enunciating is an irreducible series.

I am not going to limit myself to this simple little banter, because I could have been content to take an infinite cylinder because if it depended on that this would not take us very far. An intuitive, geometrical metaphor let us say. Everyone knows the importance that every battle between mathematicians has, it is only around elements like this that it rages. Poincaré and others maintain that there is an irreducible intuitive element and the whole school of axiomaticists claim that we can entirely formalize, starting from axioms of definition and from elements, the whole development of mathematics, namely tear it away from any topological intuition. Luckily M Poincaré understands very well that it is indeed in topology that one finds the essence of the intuitive element, and that one cannot resolve it and that I would even say further: without intuition one cannot do this science which is called topology, one cannot begin to articulate it because it is a great science.

There are big primary truths attached around this construction of the torus and I am going to make you put your finger on something: on a sphere or on a plane, you know that one can draw (23) what is called any geographical map whatsoever however complicated it may be and that in order to colour its domains in a way which does not allow any one of them to be confused with its neighbour four colours are enough.

If you find a very good demonstration of this really primary truth, you can bring it to the right quarter because you will be awarded a prize, since up to now the proof has not yet been found.

On this torus, you will not see it experimentally, but it can be proved: in order to resolve the same problem, seven colours are necessary, in other words on the torus with the tip of a pencil you can define up to seven domains but not one more, these domains being defined each one as having a common frontier with the others. This to tell you that if you have a bit of imagination, in order to see them altogether clearly, you will draw hexagonal domains.

It is very easy to show that you can draw seven hexagons on the torus and not one more, each one having with all the others a common frontier. This, I apologise for it, to give a little consistency to my object. This torus is not a bubble, it is not a puff of air; you see how one can speak about it, even though entirely, as one says in classical philosophy, as a construction of the spirit it has all the resistance of something real. Seven domains? For most of you: it is not possible. As long as I have not shown it to you you have a right to oppose this "not (24) possible" to me; why not six, why not eight?

Now let us continue. This ring here is not the only thing that interests us as irreducible; there are others that you can draw on the surface of the torus of which the smallest is what we can call the most internal of the circles, which we will call empty circles.

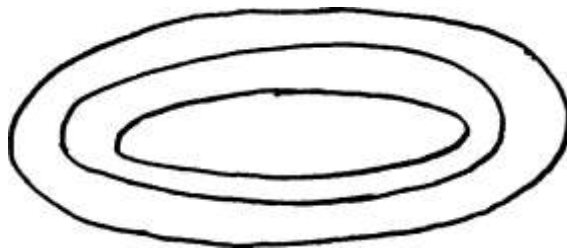

They make a circuit around this hole. One can make a lot of things of them. What is certain, is that it is apparently essential; now that it is there you can deflate your torus like a bladder and put it in your pocket, because it is not part of the nature of this torus to be always completely round, completely even; what is important is this holed structure. You can reinflate it every time you need it, but it can like the little giraffe in little Hans who made a knot of his neck....

There is something that I want to show you right away. If it is true that the synthetic enunciating in so far as it is maintained in one of these circuits, in the repetition of this one, does it not seem to you that this is going to be easy to depict. I have only to continue what I drew for you at first fully, then in dots, this will give a bobbin:

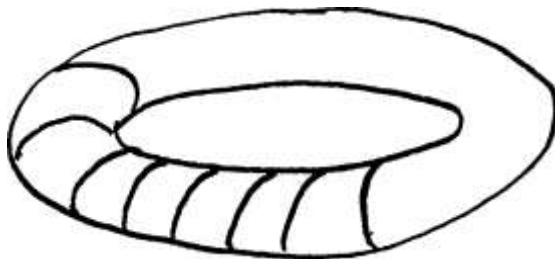

Here then are the series of circuits that they carry out in the unary repetition of what returns and what characterises the primary subject in his signifying, automatism of repetition relationship. Why not push the bobbining to the end, until this little bobbin snake bites its own tail. It is not an image to

be studied as an analyst which exists in the writings of Mr Jones.

What happens at the end of this circuit? It closes itself off; we find here moreover the possibility of reconciling what is supposed, implicated and the final return to meaning of Natiirwissenschaft with what I underline concerning the necessarily unary function of the circuit.

This does not appear to you here in the way I am representing it for you. But already there at the beginning and in so far as the subject goes through the sequence of circuits he has necessarily made a mistake of one in his count and we see reappearing here the unconscious minus one in its constitutive function. This for the simple reason that the circuit that he cannot count is the one that he made in making a circuit of the torus and I am going to illustrate it for you in an important fashion, because it is of a nature to introduce you to the function that we are going to give to two types of irreducible act, those which are full circles and those which are empty circles, regarding which you will guess that the second must have some relationships with the function of desire. Since, as compared to these circles which succeed one another, the succession of full circles, you ought to notice that the empty circles, which are in a way caught in the rings of these buckles and which unify all the circles of demand among themselves, there must be something which is related to the little object of metonymy in so far as it is this object. I did not say that it is desire that is symbolised by these circles, but the object as such which is opposed to desire.

This in order to show you the direction in which we will subsequently advance. It is only a very small beginning, the point on which I want to conclude so that you may really sense that there is no artifice in this kind of skipped circuit that I seem to be trying to get over to you by sleight of hand.

I want to show it to you before leaving you. I want to show it to you in connection with a single circuit on the the full circle. I could show it to you by making a drawing on the board. I can trace a circle which is of such a kind that it is ready to go around the whole torus. It is going to travel on the outside of the central hole then come back from the other side.



A better way to get you to sense it: you take the torus and a pair of scissors, you cut it in terms of the full circles, here it is unfolded like a black pudding open at both ends, you take

up the scissors again and you cut it length-ways, it can open completely and be spread out, it is a surface which is equivalent to that of the torus; for this it is enough that we should have so defined it that each one of its opposite edges has an equivalence implying continuity with a point of the opposite edge.

What I have drawn for you on the unfolded torus is projected as follows:

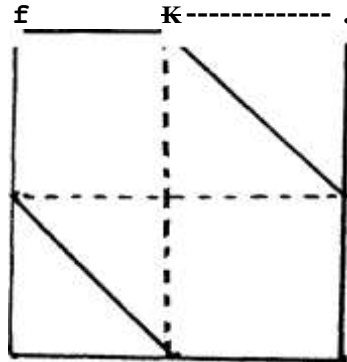

Here is how something which is nothing other than a single loop is going to be presented on the torus which has been properly cut by these two cuts of the scissors: and this oblique trait defines (26) what we can call a third type of circle, but which is precisely the circle which interests us as regards this sort of possible property that I am trying to articulate as structural of the subject; even though it only made one circuit it nevertheless well and truly made two, namely the circuit of the full circle of the torus and at the same time the circuit of an empty circle, and that as such this circuit which is missing in the count is precisely what the subject includes in the necessities of his own surface to be infinitely flat that subjectivity can only grasp by a detour: the detour of the Other, this to show you how one can imagine in a particularly exemplary fashion thanks to this topological edifice to which, have no doubt about it, I accord a little more weight than simply that of an artifice. Likewise - and for the same reason - because it is the same thing that replying to a question that was recently posed to me concerning the root of minus one as I introduced it into the function of the subject: "By articulating things in this manner", I was asked, "do you intend to make manifest something other than a pure and simple symbolisation replaceable by anything else whatsoever or something which belongs more radically to the very essence of the subject?" "Yes," I said. "It is in this sense that you should understand what I articulated before you and this is what I am proposing to continue to develop with the shape of the torus". - I am saying: on the total surface -, if this is no longer possible at the level of the central, fragmented, surface divided by the signifier of the double ring (boucle), the fact is that very precisely something of that is preserved at the level of the point.

(27) Except for the fact that precisely in order that this point should function as this point, it has this privilege of being precisely un-supersedable, unless, as one might say, by making the whole structure of the surface vanish.

As you see, I was not able yet to give its full development to what I have just said on this point. If you reflect on it, you can, between now and the next time, find it yourselves.

It is getting late, and it is here indeed that I am forced to leave you. I apologise for the aridity of what I was led to produce before you today, because of the complexity itself, even though it is not an extraordinarily punctual complexity, it must be said. This is where I will take things up the next time.

I come back therefore to what I said at the beginning: the fact that I have only been able to get to this point of my exposition means that next Wednesday¹'s seminar - tell the people who have received the next announcement - will take place in order not to leave too much space, too much of an interval between these two seminars, because this space could be harmful for the continuation of our explanations.

Seminar 13: Wednesday 14 March 1962

In the dialogue with you that I am pursuing, there are necessarily hiatuses, jumps, cases, occasions, to say nothing of fatum. In other words, it is interrupted by different things; for example last evening, at the scientific meeting of the Society, we heard the interesting and important paper by Lagache on sublimation. This morning, I wanted to begin from it, but on the other hand, on Sunday I had started from elsewhere, I mean from a sort of remark on the character of what is being pursued here as research. It is obviously a research conditioned by what? For the moment by a certain aim which I would call the aim of an erotic. I consider this to be legitimate, not at all because we are essentially destined by nature to carry it out when we are on the road where it is required, I mean that we are on this road a little in the way that, through the centuries, those who meditated on the conditions of science were on the road to what science effectively is successful at. Hence my reference to the cosmonaut which has indeed its meaning, in so far as what it was successful at was certainly not necessarily what it was expecting up to a certain point, even though the phases of its research may be abolished, refuted by its success.

It is certain that there is among the peoples - I am using this term in the most general sense, unless I am using it in a (2) slightly narrower sense, that of the gentiles - which would obviously leave open the curious question of gentiles defined with respect to X (you know where this definition of gentiles comes from) which would leave open the curious question of how it happens that the gentiles represent, as I might say, a secondary class in the sense that I meant it the last time of something founded on a certain previous acceptance. Despite everything this would not be a bad thing; because in this perspective the gentiles is Christianity, and everyone knows that Christianity as such is in a well-known relationship with the difficulties of the erotic, namely that the dealings of the Christian with Venus are all the same something that it is rather difficult to overlook, even though people pretend to take things, as I might say, in a relaxed manner.

In fact, if the essence of Christianity is to be found in the Pauline revelation, namely in a certain essential step taken in relation to the father, if the relationship of love to the father is its essential step, if it really represents the breaking through of everything great that the Semitic tradition

inaugurated about this fundamental relationship to the father of this original baraka, to which it is all the same difficult to overlook that Freud's thinking is attached more in a contradictory, maledictory fashion - we cannot doubt it - because if the reference to Oedipus may leave the question open, the fact that he ended his discourse on Moses and the way he did it, leaves no doubt that the foundation of Christian revelation is indeed therefore in this grace relationship which Paul makes (3) succeed to the law.

The difficulty is the following: it is that the Christian does not maintain himself, and with good reason, at the height of this revelation and that nevertheless he lives it in a society of such a kind that one can say that even reduced to the most lay forms its principles of law issue directly all the same from a catechism which is not unrelated to this Pauline revelation. Simply, since the meditation on the Mystical Body is not within everyone's reach, a gap remains open which means that practically the Christian finds himself reduced to something which is not all that normal or fundamental, of really no longer having any other access to jouissance as such except by making love. This is what I call his troublesome dealings with Venus. Because of course, with the way he is situated in this order, things arrange themselves after all on the whole rather badly.

What I am saying is very tangible, for example when one goes outside the boundaries of Christianity, once one goes into areas dominated by Christian acculturation, I mean not areas which have been converted to Christianity, but which have undergone the effects of Christian society. I shall long remember a long conversation pursued one night in 1947 with someone who was my guide during a trip to Egypt. He was what is called an Arab. He was, of course, through his functions and also because of the area he lived in, an excellent example of someone who falls into our category. This sort of effect of the promotion of the erotic question was very clear in his discourse. He was certainly prepared by all sorts of very antique resonances of his own (4) sphere to put in the foreground the question of the justification of the existence of his jouissance; but the fashion in which he incarnated this jouissance in the woman had all the impasse characteristics of everything that one can imagine the most open to view in our own society - the requirement in particular of a renewal of an infinite succession - what is in its nature the essentially non-satisfying character of the object, this was indeed what constituted the essential, not alone of his discourse, but of his practical life. A personage, one would have said in another vocabulary essentially torn away from the norms of his tradition.

When it is a question of the erotic, what should we think of these norms? In other words, are we charged for example with justifying the practical subsistence of marriage as an institution throughout even our most revolutionary transformations?

I believe that there is no need for all the effort of a

Westermarck to justify through all sorts of arguments, from nature and from tradition, the institution of marriage, because simply it justifies itself because of its persistence which we have seen before our eyes, and in form very clearly marked by lower middle class traits, throughout a society which at the beginning believed it could go further in the putting in question of fundamental relationships, I mean in Communist society. It seems very certain that the necessity of marriage was not even touched by the effects of this revolution. Is this properly speaking the domain into which we are led to bring some light?

(5) I absolutely do not believe it: the necessities of marriage prove themselves to be, for us, a properly social trait of our conditioning; they leave completely open the problem of the dissatisfactions which result from it namely the permanent conflict in which the human subject finds himself, just because he is human, with the effects, the repercussions of this law (of marriage).

What evidence do we have for that? Quite simply the existence of what we note, in so far as we busy ourselves with desire, I mean that there exists in societies, whether they are well organised or not, whether one makes in them in a greater or lesser abundance the constructions necessary for the environment of individuals, we note the existence of neurosis; and it is not in the places where the most satisfactory conditions of life are guaranteed, nor where tradition is most guaranteed that neurosis is more rare. Far from it.

What does neurosis mean? What is for us the authority, as I might say, of neurosis? It is not quite simply linked to its pure and simple existence. The position of those who in this case attribute its effects to a sort of displacement of human weakness is too facile, I mean that what proves effectively to be weak, in social organisation as such, is visited on the neurotic whom one describes as maladjusted. What a proof!

(6) It seems to me that the right, the authority which flows from what we have to learn about the neurotic, is the structure that he reveals to us and what at bottom it reveals to us, from the moment that we understand that his desire is indeed the same as our own, and with good reason. What comes little by little to be revealed to our study, what gives the neurotic his dignity, is that he wants to know. And in a way it is he who introduces psychoanalysis. The inventor of psychoanalysis is not Freud, but Anna O as everyone knows, and of course behind her many others: all of us.

What does the neurotic want to know? Here I am slowing down my delivery so that you can hear properly, because every word has its importance. He wants to know what real there is in that of which he is the passion, namely what real there is in the effect of the signifier, this of course supposing that we have got far enough to know that what is called desire in the human being is unthinkable except in this relationship to the signifier and the effects that are inscribed in it.

This signifier, that he himself is by his position, namely as a living neurosis, is if you refer to my definition of the signifier - it is moreover inversely what justifies it, the fact is that it is applicable - that through which this cryptogram that a neurosis is, what makes the neurotic as such a signifier and nothing more - because the subject that he serves precisely is elsewhere - this is what we call his unconscious. And this is why he is qua neurosis a signifier, according to the definition that I give you of it, it is because he represents a hidden (7) subject, but .for what? For nothing other than for another signifier.

That what justifies the neurotic as such, the neurotic in so far as analysis - I am slipping in this term borrowed from the discourse of my friend Lagache yesterday - "valorises" him, is the extent to which his neurosis manages to contribute to the advent of this discourse required by a finally constituted erotic. He, of course, knows nothing about it and is not looking for it. And we moreover, we do not have to search for it except in so far as you are here, namely that I am clarifying for you the signification of psychoanalysis in relation to this required advent of an erotic, by which you should understand that through which it is thinkable that the human being might make in this domain also - and why not - the same breakthrough and which moreover culminates in this bizarre moment of the cosmonaut in his carapace. Which allows you to think that I am not even trying to glimpse what a future erotic might give rise to.

What is certain, is that the only people who have dreamt about it in a suitable way, namely the poets, have always ended up with rather strange constructions. And if, whatever préfiguration of it may be found in something on which I spent a lot of time, the outlines of it which may be given precisely in certain paradoxical points of the Christian tradition, courtly love for example, this was in order to underline for you the quite bizarre singularities - let the people who were my listeners remember - of certain sonnets by Arnaut Daniel for example which open up to (8) us very curious perspectives on what the relationships between the lover and his lady effectively represented. This is not at all unworthy of comparison with what I am trying to situate as an extreme point about aspects of the cosmonaut. Of course, the attempt may appear to have a certain amount of mystification about, and besides it came to a sudden end. But it is altogether illuminating in order to situate for us, for example, what must be understood by sublimation. I recalled last evening that sublimation, in Freud's discourse, is inseparable from a contradiction, namely that jouissance, the aim of jouissance, subsists and is in a certain sense realised in every activity of sublimation, that there is no repression, that there is no effacing, that there is not even a compromise with jouissance, that there is a paradox, that there is a detour, that it is by ways which in appearance are contrary to jouissance that jouissance is obtained.

This is not properly speaking thinkable except precisely in so far as in jouissance the medium that intervenes, the medium

through which access is given to its essence which can only be - as I showed you - the thing, that this medium also can be nothing but a signifier. Hence this strange aspect that the lady in courtly love takes on for our eyes. We cannot come to believe in it because we can no longer identify to this degree a living subject with a signifier, a person called Beatrice with wisdom and with what was for Dante the whole, the totality of knowledge.

(9) It is not at all excluded by the nature of things that effectively Dante could have slept with Beatrice. This changes absolutely nothing in the problem. People believe they know it is not so, it is not fundamental in the relationship.

These remarks having been posed, what defines the neurotic?

The neurotic devotes himself to a curious retransformation of that whose effect he is undergoing. The neurotic, in fine, is an innocent: he wants to know. In order to know he goes off in the most natural direction, and it is naturally at the same time by this that he is deceived. The neurotic wants to retransform the signifier into what it is the sign of. The neurotic does not know, and with good reason, that it is qua subject that he has fomented the following: the advent of the signifier in so far as the signifier is the principal effacing of the thing, that it is he, the subject who by effacing all the traits of the thing, makes the signifier. The neurotic wants to efface this effacing, he wants to bring it about that this has not happened. This is the most profound meaning of the summary, exemplary behavior of the obsessional. What he always comes back to, without ever of course being able to abolish its effect - because everyone of his efforts to abolish it only reinforces it - is to bring it about that this advent of the function of the signifier has not been produced, that one can rediscover the real that was there at the origin, namely what all this is the sign of. This, I leave here indicated, initiated in order to come back to it in a more generalised and at the same time a more diversified fashion, (10) namely according to the three kinds of neurosis: phobia, hysteria and obsession, after I have completed the circuit to which this preamble is destined to bring me back to in my discourse.

This detour therefore is well designed to situate, and at the same time to justify, the double aims of our research, in so far as it is what we are pursuing this year on the terrain of identification.

However extremely metapsychological our research may appear to some by not pursuing it exactly on the edge that we are pursuing it, in so far as analysis can only be conceived of in this most escathological of aims, if I can express myself in this way, of an erotic, but impossible also without maintaining at least at a certain level the consciousness of the meaning of these aims in order to carry out appropriately in practice what you have to do, namely of course not to preach an erotic, but to deal with this fact that, even in the case of the most normal people and with a full and entire application of good will, of norms, well, it does

not work (that not alone, as M de la Rochefoucauld said, there are good marriages but no delicious ones, we can add that things have deteriorated a little more since then because there are no longer even good ones, I mean from the point of view of desire) it would be all the same a little unbelievable that such remarks could not be put in the foreground in a gathering of analysts.

(11) This does not make you for all that the propagandists of a new erotic. What situates you, what you have to do in each particular case: you have to do exactly what everyone has to do for himself and for which he has more or less need of your help, namely, while we wait for the cosmonaut of an erotic future, small scale solutions.

Let us take things up again where we left them the last time, namely at the level of privation. I hope that I made myself understood about this subject in so far as I symbolised it by this (-1), the necessarily not counted circuit, counted as minus in the best hypothesis, namely when it has made the circuit of the circuit, the circuit of the torus. The fact that I immediately gave an indication which refers the function of this -1 to the logical foundation of any possibility of a universal affirmation, namely the possibility of founding the exception - and it is this moreover that the rule requires: the exception does not prove the rule, as it is so nicely put, it requires it; it is its true principle - in short, that in drawing my little dial for you, namely in showing you that the only veritable guarantee of the universal affirmation is the exclusion of a negative trait: "there is no man who is not mortal", I may have given rise to a confusion which I intend to rectify now in order that you may know the terrain of principle on which I am making you advance. I gave you this reference, but it is clear that it must not be taken as a deduction of the whole process starting (12) from the symbolic.

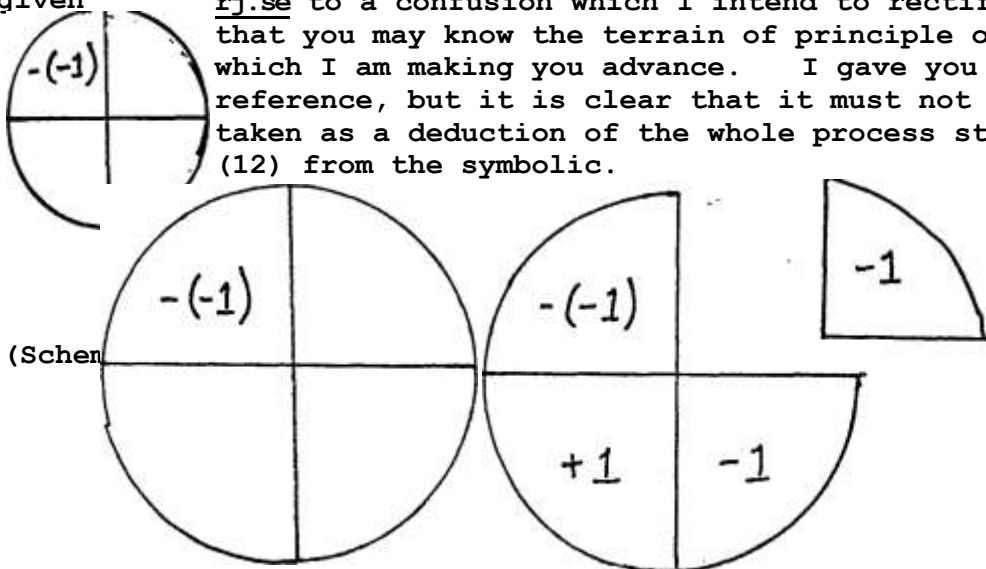

The empty part where there is nothing in my dial, must still be considered at this level as detached. The (-1) that the subject is at this level in himself is in no way subjectivated, in no way is there yet a question either of knowing, or of not knowing. For something of this order to happen, it is necessary that a whole cycle should be completed of which privation is therefore only the first step. The privation involved is real privation for which with the support of intuition which you will concede I have a right to, all I am doing here is following the very traces

of tradition, and the purest one; Kant is granted the essential of his procedure and I am seeking a better foundation for this schematism in order to try to make it tangible, intuitive for you - I forged the mainspring of this real privation. It is therefore only after a long detour that there can come to the subject this knowledge of his original rejection. But meanwhile, I tell you this right away, enough things have happened in order that when it comes to light, the subject knows not alone that this knowledge rejects him, but that this knowledge is itself to be rejected in so far as it will prove to be always either beyond, or on this side of what must be reached for the realisation of desire.

In other words that if ever the subject, and this is his goal since the time of Parmenides, arrives at the identification, at the affirmation that noein kai einai, to think and to be, are the same thing, to auto, at that moment he will find himself (13) irremediably divided between his desire and his ideal. This, as I might say, is designed to demonstrate what I could call the objective structure of the torus in question. But why should I be refused this usage of the word objective since it is classic in the domain of ideas and is still used up to Descartes? At the point therefore that we are at and in order not to come back to it any more, what is involved of the real is perfectly touchable, and that is all that is in question. What led us to the construction of the torus at the point that we are at, is the necessity to define each one of the circuits as an irreducibly different one. For this to be real, namely for this symbolic truth, since it presupposes computation, counting, to be grounded, be introduced into the world, it is necessary and sufficient that the something called the unary trait should have appeared in the real. It will be understood that before this 1, which is what gives all its reality to the ideal - the ideal is the only real that is in the symbolic and it is enough - it will be understood that at the origins of thinking, as people say, at the time of Plato and in the case of Plato not to go back any further, this gave rise to adoration, prostration: the 1 was the good, the beautiful, the true, the supreme being.

The reversal that we are encouraged to face up to on this occasion consists in grasping that however legitimate this adoration may be from the point of view of an affective elation, it nevertheless remains that this 1 is nothing other than the reality of a rather stupid little stroke. That is all. The first hunter, as I told you, who made a notch on an antelope's (14) rib in order to remember simply that he had hunted ten, twelve or thirteen times, did not know how to count, you should note, and it is even for that reason that it was necessary to put these traits, in order that the ten, twelve or thirteen all the times should not be confused as they deserved nevertheless to be one with another.

Therefore, at the level of the privation that is involved, in so far as the subject is at first objectively this privation in the thing, this privation which he does not know is that of the uncounted circuit, it is from this that we begin again in order

to understand what is happening. We have other elements of information so that from there he comes to constitute himself as desire and knows the relationship there is between this constitution and this origin in so far as it may allow us to begin to articulate some symbolic relationship more adequate than those promoted up to now concerning what his structure of desire is for the subject. This does not for all that oblige us to make assumptions about what will be maintained about the notion of the function of the subject when we have put him into the situation of desire; this is what we are obliged indeed to go through with him according to a method which is only in short the one of experience; this is the subtitle of Hegel's phenomenology Wissenschaft der Erfahrung: science of experience. We are following an analogous path with different data which are the ones which present themselves to us.

The next step is centred - I could just as well not put in a chapter heading here, I am doing it for didactic purposes - it is that of frustration. It is at the level of frustration that there is introduced with the Other the possibility for the (15) subject of a essential new step. The 1 of the unique all, the 1 which distinguishes each repetition in its absolute difference, does not come to the subject, even if its support is nothing other than that of the real stroke, does not come from any heaven, it comes from an experience constituted for the subject with whom we have to deal, by the existence, before he was born, of the universe of discourse, by the necessity that this experience supposes the locus of the Other with a big 0 as I have previously defined it.

It is here that the subject is going to conquer the essential, what I called this second dimension, in so far as it is a radical function of his own location in its structure if it is the case that metaphorically, but not without claiming in this metaphor to reach the very structure of the thing, we call this second dimension a torus structure in so far as among all the others it constitutes the existence of loops irreducible to a point, of non-vanishing loops. It is in the Other that there comes necessarily to be incarnated this irreducibility of the two dimensions in so far as, if it is tangible somewhere, it can only be, because up to the present the subject is only for us the subject in so far as he speaks, in the domain of the symbolic. It is in the experience of the symbolic that the subject must encounter the limitation of his displacements which makes him enter at first into the experience of the high point, as I might say, the irreducible angle of this duplicity of the two dimensions.

This is how the schema of the torus is going to be of the (16) greatest use to me - as you are going to see - by starting from the experience so highly valued by psychoanalysis and the observation that it gives rise to. The subject can attempt to speak the object of his desire. He does nothing but that. It is more than an act of enunciating, it is an act of imagining. This gives rise in him to a manoeuvre of the imaginary function and this function necessarily reveals itself to be present once

frustration appears. You know the importance, the accent that I in the wake of others, specifically St Augustin, put on the moment of the awakening of jealous passion in the constitution of this type of object which is the very one that we have constructed as underlying each of our satisfactions: the little child a prey to jealous passion before his brother who for him makes arise in an image the possession of this object, specifically the breast, which up to then was only the underlying object elided, masked for him behind this return of a presence linked to each of his satisfactions, which was in this rhythm where there is inscribed, where there is sensed the necessity of his first dependency, only the metonymical object of each one of its returns; here it is suddenly produced for him in the light with effects signaled for us by his mortal pallor, the light of the something new which is desire: the desire of the object as such in so far as it resonates to the very foundation of the subject, that it shakes him well beyond his constitution as satisfied or not, as suddenly menaced in his innermost being, as revealing his fundamental lack, and this in the form of the Other as bringing to light both metonymy and the loss it conditions.

(17) This dimension of loss essential to metonymy, the loss of the thing in the object, is the true sense of this thematic of the object qua lost and never refound, the same one which is at the basis of the Freudian discourse and is ceaselessly repeated. One further step, if we push metonymy further, as you know, it is the loss of something essential in the image, in this metonymy, which is called the ego, at this point of the birth of desire, at this point of pallor at which St Augustin pauses before the infant at the breast as Freud did before his grandson eighteen centuries later. It is false to say that the being of which I am jealous, the brother, is my fellow (semblable): he is my image in the sense that the image involved is the founding image of my desire. Here is the imaginary revelation, and it is the meaning and the function of frustration. All of this is already known. I am only recalling it as the second source of the experience.

After real privation, imaginary frustration. But, just as I tried today to situate for you the use of real privation at the term which interests us, namely in the founding of the symbolic, in the same way, we have to see here how this fundamental revelatory image of desire is going to be placed in the symbolic. This placing is difficult. It would of course be quite impossible if the symbolic were not there, if - as I have reminded you, always hammered out for a long enough time for this to have got into your head - if the Other and the discourse in which the subject has to place himself were not always waiting for him before his birth and that he is spoken to, at least (18) through the mediation of his mother, of his nurse. The mainspring involved, the one which is both the abc, the infancy of our experience, but which for some time people do not know how to go beyond for want precisely of knowing how to formalise it as abc, is the following, namely the intersection, the naive exchange which is produced somewhere in the dimension of the Other between desire and demand.

If there is, as you know, something which as one might say the neurotic allows himself to be caught by from the start, it is this trap; and he will try to make what is the object of his desire pass into the demand, to obtain from the Other, not the satisfaction of his need, for which the demand is made, but the satisfaction of his desire, namely to have its object, namely precisely what cannot be demanded - and this is at the origin of what is called dependency in the relationships of the subject to the Other - just as he will try more paradoxically still to give satisfaction by conforming his desire to the demand of the Other; and there is no other meaning, of correctly articulated meaning I mean, to what is the discovery of analysis and of Freud, to the existence of the super-ego as such. There is no other correct definition, I mean no other one which allows us to escape from confusing slippages.

I think without going any further, that the practical, day-to-day concrete resonances, namely the impasse of the neurotic, is at first and above all the problem of the impasses of his desire, this impasse which is tangible at every moment, massively tangible, and against which you always see him stumbling. This is what I would summarily express by saying that for his desire (19) he has to have the sanction of a demand. What do you refuse him, if not what he is waiting for you to demand of him - to desire appropriately? Without going into what he expects from his spouse, from his parents, from his offspring and from all the conformities which surround him. What does this allow us to construct and to perceive?

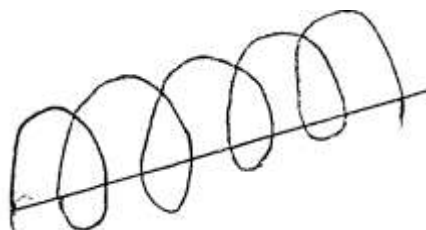
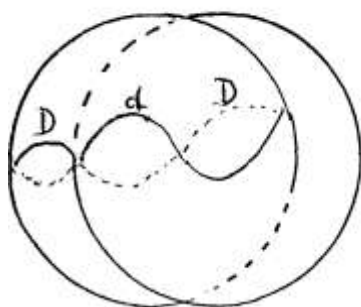

If it is the case that demand is renewed in accordance with the circuits that have been made, in accordance with the full circles all around and the successive returns which the return of need, but encompassed by the loops of demand, necessitates, if it is a fact that, as I gave you to understand through each of these returns, which allows us to say that the elided circle, the circle which I simply called the empty circle in order that you should see what I mean with respect to the torus, comes here to materialise the metonymical object beneath all these demands. A topological construction is imaginable of another torus which has the property of allowing us to imagine the application of the object of desire, the internal empty circle of the first torus, onto the full circle of the second which establishes a buckle,

one of these irreducible loops.

(20) Inversely the circle of a demand on the first torus is here superimposed on the other torus. The torus here a support of the Other, the imaginary Other of frustration, is superimposed on the empty circle of this torus, namely fulfils the function of showing this inversion: desire in one, demand in the other, demand of the one, desire of the other, which is the knot in which there is trapped the whole dialectic of frustration. This possible dependency of two topologies, that of one torus on that of the other, expresses in short nothing other than what is the goal of our schema in so far as we support it by the torus. The fact is that if the space of Kantian intuition ought, I might say, thanks to the new schema that we are introducing here, be put in parenthesis, cancelled out, aufgehoben, as illusory because the topological extension of the torus allows us to consider only the properties of the surface, we are sure of the permanence, of the solidity, as I might say, of the volume of the system without having to have recourse to the intuition of depth. What this images, as you see, is that by maintaining ourselves, in the whole measure that our intuitive habits allow us, within these limits, what results is that since all that is involved between these two surfaces is a substitution by a bi-univocal application, even though it is inverted, namely that once it is cut out this will be in this direction on one of the surfaces and in this other direction on the other.

(Schema
)

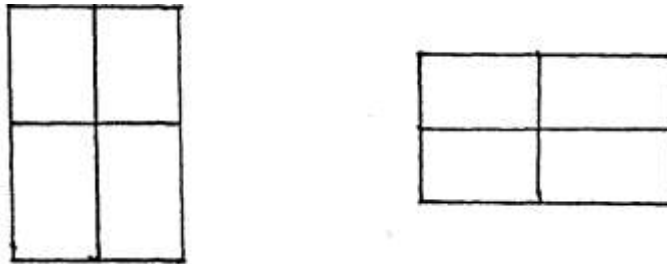

(21) It remains nonetheless that what this makes tangible, is that from the point of view of the required space, these two spaces: the inside and the outside, from the moment that we refuse to give them any substance other than a topological one, are the same. This is what you will see expressed in the sentence that the already indicate, in the Rome report, the use that I counted on making of it for you, namely that the property of the ring in so far as it symbolises the function of the subject in his relationships to the Other depends on the fact that his inside space and his outside space are the same: starting from there the subject constructs his outside space on the model of the irreducibility of his inside space.

But what this schema shows clearly, is the lack of ideal harmony which might be required between the object and the demand, between the demand and the object, an illusion which is sufficiently demonstrated by experience, I think, for us to have experienced the need to construct this necessary model of their necessary discordance. We know the source of this, and of course, if I seem to be advancing only slowly believe me: no

stagnation is too much, if we want to assure ourselves of the next steps. What we already know, and what is intuitively represented here, is that the object itself as such, qua object of desire, is the effect of the impossibility of the Other to respond to demand. This is what is seen here manifestly in this sense that, whatever may be his desire, the Other cannot suffice for the aforesaid demand, that he necessarily leaves open the (22) greater part of the structure, in other words that the subject is not enveloped, as is believed, in the all, that at the level at least of, the subject who speaks the Umwelt does not envelop his Innenwelt; that if there was something to be done to imagine the subject in relation to the ideal sphere, always the intuitive and mental model of the structure of a cosmos, it would be rather that the subject would be, if I may allow myself to push it, to exploit for you - but you see that there is more than one way of doing it - my intuitive image, it would be to represent the subject by the existence of a hole in the aforesaid sphere and his supplement by two sutures.

(Schema)

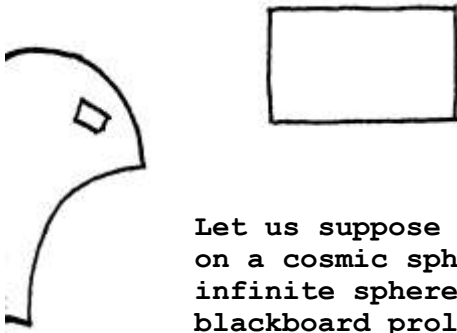

Let us suppose the subject to be constituted on a cosmic sphere. The surface of an infinite sphere is a plane: the plane of the blackboard prolonged indefinitely.



Here is the subject, a quadrangular hole, like the general configuration of my skin earlier, but this time in the negative. I stitch one edge to the other, but with this condition that they are the two opposite edges, that I leave the two other edges free. From this there results the following figure:

(23) namely, with the void filled in here, two holes which remain in the sphere of infinite surface. You have only to pull on each of these edges of these two holes to constitute the subject on the infinite surface as constituted in short by what is always a torus even if it has a paunch of infinite radius, namely a handle emerging at the surface of a plane.



This is what, at its maximum, the relationship of the subject to the great All means at its maximum. We will see the applications that we can make of it.

What is important to grasp here, is that for this overlapping between the object and the demand if the imaginary Other thus constituted in the inversion of the functions of the circle of desire with that of demand, the Other as regards the satisfaction of the desire of the subject must be defined as without power

(sans pouvoir). I insist on this "without", because with it there emerges a new form of negation in which there is indicated properly speaking the effects of frustration. Without is a negation, but not an indifferent one: it is a liaison-negation which is well materialised in the English tongue, by the conformist homology of two relationships of the two signifiers: within and without. It is a bound exclusion which already in itself alone indicates its reversal.

(24) Let us take a further step, it is that of the "not without" (pas sans). The Other is introduced of course into the naive perspective of desire as without power, but essentially what links him to the structure of desire is the "not without". He is not either without power; this is why this Other whom we have introduced qua metaphor in short of the unary trait, namely of what we find at his level and what he replaces in an infinite regression because it is the locus where there succeed one another these l's which are all different from one another, of which the subject is only the metonymy, this Other as one - and the play on words is part of the formula that I am employing here to define the mode in which I introduced it - is rediscovered once there is completed (bouclée) the necessity of the effects of imaginary frustration as having this unique value, because it alone is not without, not without power: it is posed as condition at the possible origin of desire, even if this condition remains in suspense. For this it is like not one (comme pas un); it gives to the (-1) of the subject another function which is incarnated at first in this dimension, that this "like" situates well enough for you as being that of metaphor. It is at its level, the level of the "like not one" and of everything which is going to remain suspended from it subsequently, as what I have called the absolute conditionality of desire, that we will have to deal the next time, namely the level of the third term, of the introduction of the act of desire as such, of its relationships to the subject on the one hand at the root of this power, at the rearticulation of the moments of this power, in so far as - as you see - I shall have to go back over the not possible (pas possible) to mark the path that has been completed by the introduction of the terms power and without power. It is in so (25) far as we will have to pursue this dialectic the next time that I stop here today.

Seminar 14: Wednesday 21 March 1962

(Schema I)

I left you the last time with this symbolic embrace of two toruses in which there is imaginarily incarnated the relationship of inversion, as one might say, experienced by the neurotic in which we see tangibly, clinically that apparently at least it is on a dependency on the demand of the Other that he tries to found, to establish his desire. Of course, there is something well grounded in this structure that we describe as the structure of the subject in so far as he speaks, which is the one for which I am fomenting for you this topology of the torus that I believe to be very fundamental. It has the function of what one calls moreover in topology the fundamental group, and after all this will be the question to which it will be necessary for us to indicate a response. I hope that this response, at the moment when it is necessary to give it, will already truly be superabundantly sketched out.

Why, if this is the fundamental structure, was it so profoundly miscognised for such a long time throughout the ages by philosophical thought, why if things are this way was it the (2) other topology, that of the sphere, which traditionally appears to dominate every elaboration of thinking concerning its relationship to the thing.

Let us take up things where we left them the last time and where I was indicating for you what is implied in our very experience: there is in this knot with the Other, in so far as it is presented to us as a first tangible approximation, perhaps one that is too easy - we will see that it certainly is - there is in this knot with the Other, as it is imaged here, a relationship of lure. Let us return here to the present, to what is articulated about this relationship to the Other. We know it. How would we not know it when we are every day the very support of its pressure in analysis and when the neurotic subject, with whom we have to deal fundamentally, presents himself before us as requiring from us the response, even if we teach him the value there is in suspending this response.

The response about what? This indeed is what justifies our schema, in so far as it shows us desire and demand being substituted for one another; it is precisely because the response is about his desire and about its satisfaction. What no doubt today I will be almost certainly limited by the time that I am

accorded, is to properly articulating the co-ordinates on which there are suspended this demand made on the Other, this demand for a response, which specifies the true explanation, the final explanation, with respect to which every approximation is insufficient, of what in Freud is pinpointed as Versagen, (3) Versagung: the retraction, or again the deceiving word, the breaking of a promise, at the limit the Vanitas at the limit of the bad word and the ambiguity - I recall it for you here - which unites the term blasphemy to what it has given rise to through all sorts of transformations, in themselves moreover very interesting to follow: blame. I will not go any further along this path.

The essential relationship to the word of the frustration that we are dealing with to the word is always the radical point to sustain, to maintain, otherwise our concept of frustration becomes degraded: it degenerates until it is reduced to the lack of gratification with regard to what in the final analysis can no longer be conceived of as anything but need. Now, it is impossible not to recall what the genius of Freud establishes for us as original in what concerns the function of desire, what he began with in his first steps - let us leave to one side the letters to Fliess, let us begin with The interpretation of dreams and let us not forget that Totem and taboo was his favourite book - the aforesaid genius of Freud establishes for us the fact that desire is fundamentally, radically structured by this knot which is called the Oedipus complex, and is something from which it is impossible to eliminate this internal knot that I am trying to sustain before you by these figures, this internal knot which is called the Oedipus complex in so far as it is essentially what? It is essentially the following: a relationship between a demand which takes on such a privileged value that it becomes the absolute commandment, the law, and a desire, which is the desire of the Other, the Other involved in the Oedipus complex. This (4) demand is articulated as follows: Thou shalt not desire her who has been my desire. Now it is this which founds in its structure the essential, the beginning of the Freudian truth. And it is here, it is starting from here that any possible desire is in a way obliged to take this sort of irreducible detour, this something similar to the impossibility in the torus of the reduction of the loops on certain circles which means that desire must include in itself this void, this internal hole specified in this relationship to the original law. Let us not forget that the steps to found this first relationship around which - we forget it all too easily - are articulatable for Freud - and only in this way - all the Liebesbedingungen, all the determinants of love, let us not forget the steps that this requires in the Freudian dialectic that it is in this relationship to the other, the father who has been killed, beyond this death of the original murder that there is constituted this supreme form of love. It is a paradox not at all dissimulated even if it is elided by this veil over the eyes which always seems to accompany here the reading of Freud: this moment cannot be eliminated that after the murder of the father there arises for him - even if this is not sufficiently explained for us, it is well enough so for us to retain the moment as essential in what one can call the mythical

structure of the Oedipus complex - this supreme love for the father, which makes precisely of this death of the original murder the condition of his henceforth absolute presence. Death in short playing this role manifested itself as alone being able to fix him in this sort of reality, no doubt the only absolutely durable one, of being as absent; there is no other source to the absoluteness of the original commandment.

(5) Here is where there is established the common field in which the object of desire is set up in the position that we know already of course to be necessary for it even at the imaginary level, namely a third position: the simple dialectic of the relationship to the other qua transitive in the imaginary relationship of the mirror stage, has already taught you that it established the object of human interest as linked to his fellow, the object o here with respect to this image which includes it, which is the image of the other at the level of the mirror stage: i of o. But this interest in a way is only a form, it is the object of this neutral interest around which even the dialectic of M Piaget's enquiry could be ordered, by putting in the foreground this relationship that he describes as one of reciprocity that he believes that he can join up to a radical formula of the logical relationship. It is from this equivalence, from this identification to the other as imaginary, that the ternarity of the emergence of the object is established; it is only a partial, insufficient structure and therefore one that we should find, finally, as deductive of the setting up of the object of desire at the level where I am articulating it for you here today. The relationship to the Other is not at all this imaginary relationship founded on the specificity of the generic form, because this relationship to the Other is specified by the demand in so far as it makes emerge from this Other, which is the Other with a big O, its "essentialness", as I might say, in the establishment of the subject, or, to take up again the form that is always given to the verb inter-esser its "inter-essentialness" to the subject. The field in question cannot therefore in any way be reduced to the field of need and of the object which (6) because of the rivalry of his fellows may at the limit be imposed - because this would be the slope down which we would find our recourse for the final rivalry - be imposed as object of subsistence for the organism. This other field, which we are defining and for which our image of the torus is made, is another field, a field of the signifier, a field of the connotation of presence and absence and where the object is no longer the object of the subsistence, but of the ex-sistence of the subject. In order to demonstrate it, it is indeed a matter in the final analysis of a certain place of ex-sistence necessary for the subject and that this is the function to which there is raised, brought the small o of the first rivalry.

We have before us the path which we still have to take of this mountain peak to which I led you the last time of the dominance of the other in the setting up of the frustrating relationship; the second part of the path should lead us from frustration to this still to be defined relationship which as such constitutes the subject in desire, and you know that is it only there that we

can properly articulate castration. We will not know therefore in the final analysis what this place of ex-sistence means until this path has been completed. From now, we can, we ought even to recall, but recall here to the philosopher who has no introduction to our experience, this point which it is peculiar to see so often shied away from in his own discourse, which is that there is indeed a question, namely why it is necessary that the subject should be represented - and I mean in the Freudian sense represented by an ideational representative - as excluded from the very field in which he has to act in what we could call Lewinian relationships with others as individuals, that it is necessary that at the level of structure we should manage to (7) account for why it is necessary that he should be represented somewhere as excluded from this field in order to intervene in this field itself. Because, after all, all the reasonings into which the psycho-sociologist draws us in his definition of what I have just called a Lewinian field are never presented without a complete elision of this necessity that the subject should be, let us say, in two topologically defined places, namely in this field but also essentially excluded from this field, and that he manages to articulate something and something which holds up. Everything that in a thinking about the behaviour of man as observable comes to be defined as learning and at the limit the objectification of learning, namely montage, forms a discourse which holds up and which up to a certain point takes into account a whole lot of things, except for the fact that effectively the subject functions, not with this simple use as I might say but in a double use, which is all the same worth dwelling on and which, however fleetingly it is presented to us, is tangible in so many ways that it is enough, as I might say, to bend down to gather up proofs of it. It is nothing other that I am trying to get you to sense every time for example that I bring in incidentally the traps of the double negation and that the "I do not know whether I want to" is not understood in the same way I think as the "I know that I do not want to".

Reflect on these never to be exhausted little problems - because the logicians of language work at them and their stammerings in this regard are more than instructive - that as long as there are words which flow and even writers who allow things to flow from (8) the tip of their pen in the way they talk, you will say to someone - I already insisted on it, but one cannot come back too much on it - "You cannot fail to know (vous n'êtes pas sans ignorer)" in order to tell him: "You know well all the same". The double plane on which this operates is something that is self-evident. That someone may write like that and that it has happened was recalled to me recently in one of these texts of Prevert which astonished Gide: "Was he trying to mock himself or does he really know what he is writing?" He did not want to mock himself: it flowed from his pen and all the critique of logicians will not help us to realize, if we are engaged in a veritable dialogue with someone, that it is a matter in some way or other of a certain essential condition in our relationships with him - which is the one to which I hope to get a little later - that it is essential that something should be set up between us as ignorance, that I will slip into saying to him, however learned

and however purest I may be, "You cannot fail to know".

The same day that I was talking to you here, I avoided quoting what I had just read in Le Canard Enchaîné at the end of one of these purple passages which are carried under the signature of Andre Ribaud entitled La Cour: "il ne faut pas se decombattre" (in a pseudo-Saint-Simon style, just as Balzac wrote a XVIIth century tongue entirely invented by himself) "de quelque defiance des rois".

You understand perfectly what that means. Try to analyse it logically and you see that it means exactly the opposite of what you understand; and you are naturally quite within your rights to (9) understand what you understand because it is in the structure of the subject: the fact that the two negations which are superimposed here, not alone do not cancel one another out, but sustain one another quite effectively depends on the existence of a topological duplicity which means that "il ne faut pas se decombattre" is not said on the same plane, as I might say, where there is set up the "quelque defiance des rois": the enunciating and the enunciation, as always, are perfectly separable but here the gap between them explodes.

If the torus as such can be of use to us, you will see, as a bridge, already proves to be enough to show us what the ambiguity of the subject consists in once it has passed into this world of redoubling, would it not be well moreover in this place, to pause at something which this topology obviously involves, and first of all in our most simple experience, I mean that of the subject. When we speak about commitment, is there any need for big detours for the ones that here I make you take because of what is required by our cause, do we need big detours for the least initiated people to evoke the fact that to commit oneself implies already in oneself the image of a corridor, the image of the entrance and of the exit and up to a certain point the image of the way out behind oneself being closed, and that it is indeed in this relationship to this "no exit" that the final term of the image of commitment is revealed.

Is much more necessary, and a whole literature which culminates in the work of Kafka allows us to grasp that it is enough to reverse what, it appears, the last time I did not sufficiently (10) image in showing you this particular form of the torus in the form of a handle standing out from a plane, the plane only presenting here the particular case of an infinite sphere enlarging one side of the torus. It is enough to upturn this image, to present it belly up and like the earthly field where we sport and play to show us the very reason why man presents himself to us as what he was and perhaps what he remains: a burrow animal, a torus animal. All his architectures are not all the same without something which ought to strike us because of their affinity with something which must go much further than the simple satisfaction of a need, because of an analogy which is obviously irreducible, impossible to exclude between anything which is called by him inside and outside and that both one and the other flow into one another and determine what I called a

little earlier the corridor, the gallery, the underground: Notes from the underground, Dostoievski entitled this extreme point where he punctuates the palpitation of his final question. Is this something which is exhausted in the notion of a socially useful instrument? Of course, like our two toruses, the function of the social agglomerate and its relationship to pathways in so far as their anastomosis simulates something which exists in the innermost part of the organism is for us a prefigured object of interrogation, it is not our privilege: the ant and the termite know it, but the badger in his set that Kafka speaks to us about is not precisely for his part a social animal.

What does this reminder mean for us, at the point that we have to (11) bring ourselves to, if not that if this structural relationship is so natural that provided we think about it we find it everywhere and its roots very deeply plunged into the structure of things, the fact that when it is a matter of thinking organising itself, it fails so abundantly throughout the ages to recognise the relationship of the subject to the world, poses precisely the question of why repression, or at least we could say miscognition, has gone so far here.

This brings us back to our starting point which is that of the relationship to the Other, in so far as I described it as founded on some lure which it is now a question of articulating elsewhere than this natural relationship because moreover we see clearly the degree to which it can be hidden from thinking, how much thinking refuses it. It is from elsewhere that we will have to begin and from the position of the question to the Other, of the question about his desire and its satisfaction. If there is a lure, it must depend in some way on what I called earlier the radical duplicity of the position of the subject; and it is this that I would like to make you sense at the proper level then of the signifier in so far as it is specified by the duplicity of the subjective position, and ask you to follow me for a moment onto something which is called in the final analysis the difference for which the graph which I kept you to for a certain time of my discourse is properly speaking forged: this difference is called the difference between the message and the question.

This graph which could be so well inscribed here: (schema II) in the very gap through which the subject is doubly linked up to the (12) universal plane of discourse, I am going today to inscribe on it the four meeting points which are the ones that you know: 0; $s(0)$ the signification of the message in so far as it is the return coming from the Other, of the signifier which resides in him; here: $\$OD$ the relationship of the subject to the demand, in so far as there is specified here the drive; here: the $S(\$)$, the signifier of the Other in so far as the Other himself in the final analysis can only be formalised, be made significant as himself marked by the signifier, in other words in so far as it imposes on us the renunciation of any metalanguage. The gap that it is a matter of articulating here is entirely suspended on the form in which in the final term this demand to the Other to respond, alternates, oscillates in a succession of returns between the "nothing maybe" and the "maybe nothing" (le rien)

peut-être et le peut-être rien). Here it is a message (schema III). It opens out onto what has appeared to us as the opening established by the entry of a subject into the real. We are here in accord with the most certain elaboration of the term possibility: Möglichkeit. It is not on the side of the thing that the possible is, but on the side of the subject. The message opens itself out onto the term of the eventuality constituted by an expectation in the constituting situation of desire, as we are trying to get close to it here. "Maybe": the possibility is anterior to this nominative "nothing" which at the extreme point, takes on the value of a substitute for positiveness. It is a point and only a point. The place of the unary trait is reserved there in the void which can respond to the expectation of desire. It is a completely different thing to the question in so far as it is articulated: (schema IV) "nothing maybe"?

(13) That the maybe at the level of the demand that is put in question: "What do I want?" speaking to the Other, that the maybe comes here in a position homological to that which at the level of the message constituted the eventual response "maybe nothing", is the first formulation of the message. "Maybe nothing", this may be a response, but is it the response to the question "nothing maybe?". Precisely not. Here the enunciative "nothing" as posing the possibility of the failure to conclude at first as anterior to the mark of existence, to the power of being, this enunciative at the level of the question takes on all its value from a substantiating of the nothingness of the question itself. The sentence "nothing maybe" opens up, for its part, onto the probability that nothing determines it as question, that nothing at all is determined, that it remains possible that nothing is sure, that it is possible that one cannot conclude except by having recourse to the infinite anteriority of Kafka's The Trial, that there is a pure subsistence of the question with an impossibility of concluding.

Only the eventuality of the real allows something to be determined and the nomination of the nothingness of the pure subsistence of the question is what we have to deal with, at the level of the question itself. "Maybe nothing" could have been a response at the level of the message, but the message was precisely not a question. "Nothing maybe?" at the level of the question only gives a metaphor, namely the power of being is from the beyond, any eventuality has already disappeared from it and any subjectivity also. There is only an effect of meaning, an infinite referring on of meaning to meaning, except that, for us analysts, we are accustomed by experience to structure this referring on on two planes and that this is what changes everything, namely that the metaphor for us is condensation, (14) which means two chains and that the metaphor makes its appearance in an unexpected fashion right in the middle of the message, that it also becomes message in the middle of the question, that the question "family" begins to be articulated and that there emerges right in the middle the million of the millionaire, that the irruption of the question in the message occurs in that it is revealed to us that the message manifests

itself right in the middle of the question, that it comes to light on the path where we are called to the truth, and it is through our question about the truth - I mean the question itself and not the response to the question - that the message comes to light.

It is therefore on this precise point, which is precious for the articulation of the difference between enunciating and enunciation, that we had to pause for a moment. If this possibility of the nothing is not preserved, it prevents us from seeing, despite this omnipresence which is at the source of every possible properly subjective articulation, this gap which is equally very precisely incarnated in the passage from the sign to the signifier in which we see appearing that this is what distinguishes the subject in this difference: is he, for his part, sign when all is said and done, or signifier.

Sign, sign of what? He is precisely the sign of nothing. If the signifier is defined as representing the subject for another signifier - indefinite referring on of meanings - and if this signifies something, it is because the signifier signifies for (15) the other signifier this privileged thing that the subject is qua nothing. It is here that our experience allows us to throw into relief the necessity of the path by means of which there is supported any reality identifiable in the structure in so far as it is the one which allows us to pursue our experience.

The Other does not give any response therefore except that nothing is sure, but this has only one meaning: the fact is that there is something that he wants to know nothing about and it is very precisely this question. At this level the impotence of the Other is rooted in an impossible which indeed is the same one on whose path we have already conducted the question of the subject. "Not possible" was this void in which the unary trait with its dividing value came to emerge. Here we see this impossible embodying itself and joining up with what we have seen earlier was defined by Freud about the constitution of desire in the original prohibition. The impotence of the Other to respond is due to an impasse and this impasse - as we know - is called the limitation of his knowledge. "He did not know that he had died", that he has come to this absoluteness of the Other only by a death not accepted but undergone, and undergone because of the desire of the subject; this the subject knows, as I might say: that the Other must not to know it, that the Other demands not to know it, this is the privileged part in these two not-to-be-confused demands: that of the subject and that of the Other. The fact is that precisely desire is defined as the intersection of that which in the two demands is to be not said. It is only starting from there that there are liberated the demands formulatable everywhere else except in the field of desire.

(16) Thus desire is established at first from its nature of being that which is hidden from the Other by structure; it is precisely the impossible to the Other that becomes the desire of the subject. Desire is established as the part of the demand which

is hidden from the Other. It is here that this Other who guarantees precisely nothing qua Other, qua locus of the word, takes on his constructive incidence. He becomes the veil, the covering, the source of the occultation of the very place of desire and it is here that the object is going to put itself under cover, that if there is an existence which is constituted at first it is that and that it substitutes itself for the existence of the subject himself because the subject qua suspended on the Other remains equally suspended on the fact that on the side of the Other nothing is sure except precisely that he is hiding, he is covering something which is this object, this object which is still maybe nothing in so far as it is going to become the object of desire.

The object of desire exists as this very nothing which the Other cannot know to be all it consists in; this nothing takes on consistency qua hidden from the Other, it becomes the envelope of every object before which the very question of the subject comes to a halt in so far as the subject then does not become more than imaginary. The demand is liberated from the demand of the Other in the measure that the subject excludes this not-knowing of the Other. But there are two possible forms of exclusion: "I wash my hands of what you know or what you do not know, and I act", "you cannot fail to know" means how much I could not be bothered whether you know or whether you do not know. But there is also the other way; "it is absolutely necessary that you should know", (17) and this is the path that the neurotic chooses, and it is for that reason that he is, as I might say, designated in advance as a victim. The right way for the neurotic to resolve the problem of this field of desire qua constituted by this central field of demands which precisely intersect and for that reason must be excluded, is that for his part he finds that the right way is that you should know. If it were not so, he would not be doing a psychoanalysis.

What the Ratman doing getting up at night like Theodore? He shuffles along in his slippers towards the corridor to open the door to the ghost of his dead father in order to show him what? That he has a hard-on. Is this not the revelation of a fundamental behaviour? If he is not able, since it is obvious to him that the Other is not able to do anything, the neurotic wants him at least to know. I spoke to you a little earlier about commitment: the neurotic, contrary to what is believed is someone who commits himself as subject. He shuts himself off from the double outcome of the message and the question; he puts himself in the balance to decide between the "nothing maybe" and the "maybe nothing", he poses himself as a real in face of the Other, namely as impossible. Of course this will be clearer to you if you know how it happens. It is not for nothing that today I brought forward this image of the Freudian Theodore in his nocturnal and phantastical exhibition, the fact is that there is indeed some medium, and to put it better, some instrument for this unbelievable transmutation between the object of desire and the existence of the subject and which is precisely the phallus. (18) But this is reserved for our next remarks. Today I am noting simply that phallus or not the neurotic comes on the scene

as something of the real which specifies itself as impossible. This is not exhaustive; because we cannot apply this definition to phobia. We can only do it the next time, but we can apply it very well to obsessional. You will understand nothing about an obsessional if you do not remember this dimension that he the obsessional incarnates because of the fact that he is too much - it is his form of the impossible - and that once he tries to come out of his ambush position as a hidden object, he has to be a nowhere object. Hence this kind of almost ferocious avidity in the obsessional to be the one who is everywhere in order precisely to be nowhere.

The obsessional¹'s taste for ubiquity is well known, and if you do not spot it you will understand nothing about most of his behaviour. The least thing, because he cannot be everywhere, is in any case to be in several places at once, namely that in any case he can nowhere be laid hold of.

The hysteric has another mode which is of course the same, because it is the root of this one, even though less easy, less immediate to understand. The hysteric also can pose herself as real qua impossible. Her trick then is that this impossible will subsist, if the Other admits her as sign. The hysteric poses herself as the sign of something in which the Other could believe; but even though she constitutes this sign she is quite (19) real and it is necessary at all costs that this sign impose itself and mark the Other.

Here therefore is where there ends up this structure, this fundamental dialectic which entirely reposes on the ultimate weakness of the Other as a guarantee of what is sure. The reality of desire is established there and takes its place there through the medium of something whose paradox we can never stress too much, the dimension of the hidden, namely the dimension which is indeed the most contradictory one that the spirit can construct once it is a question of the truth. What is more natural than the introduction of this field of truth if not the position of a omniscient Other, to the point that the sharpest, the keenest philosopher cannot sustain the very dimension of the truth, except by supposing that it is this science of the one who knows everything which allows him to sustain it.

And nevertheless nothing of the reality of man, nothing of what he seeks for nor of what he follows can be sustained except by this dimension of the hidden, in so far as it is the guarantee that there is indeed an existing object that infers and gives by reflection this dimension of the hidden; when all is said and done it is what gives its only coherence to this other problematic. The source of all faith and eminently of faith in God is indeed the fact that we move about in the very dimension of the fact that even though the miracle of the fact that he must know everything gives him in short his whole subsistence, we act as if he always knew nothing about nine tenths of our intentions. "Not a word to the Queen Mother", this is the principle upon which every subjective constitution is unfolded and is carried out.

(20) Is it not possible that a behaviour might be conceived which measures up to this true status of desire and is it even possible for us not to see that despite appearances, despite the age-old chit-chat of the moralist, nothing, not a step of our ethical behaviour can be sustained without an exact mapping out of the function of desire? Is it possible for us to content ourselves with examples like the one Kant gives, when to reveal for us the irreducible dimension of practical reason, he gives as example that the honest man, even at the height of his happiness, cannot fail at least for a moment to consider whether he might not renounce this happiness in order not to bear false witness against an innocent man for the benefit of the tyrant. An absurd example because in our own day, but just as much in the time of Kant, is the question not altogether elsewhere? Because the just man is going to weigh up, yes, whether if in order to preserve his family he should or should not bear false witness. But what does that mean? Does that mean that, if he is giving a handle in this way to the hatred of the tyrant against the innocent man, he could bear true witness, denounce his little pal as a Jew when he really is one.

Is it not here that there begins the moral dimension which is not to know what duty we should fulfill or not vis-a-vis the truth, nor whether our behaviour falls under the universal rule, but whether we should or not satisfy the desire of the tyrant?

(21) Here is the ethical balance properly speaking; and it is at this level that without making intervene any dramatics from outside - we have no need for it - we also have to deal with what, at the end of the analysis, remains suspended on the Other. It is in so far as the measure of unconscious desire at the end of analysis still remains implicated in this locus of the Other that we incarnate as analysts, that Freud at the end of his work can mark as irreducible the castration complex as unassignable by the subject.

This I will articulate the next time, committing myself to allow you to glimpse at least that a correct definition of the function of phantasy and of its assumption by the subject allows us maybe to go further in the reduction of what has appeared up to now in experience as a final frustration.

21. 3. i 1

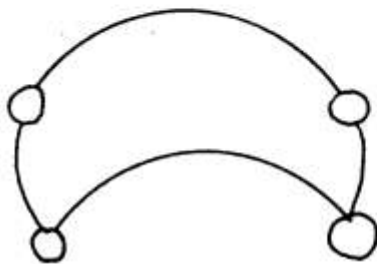
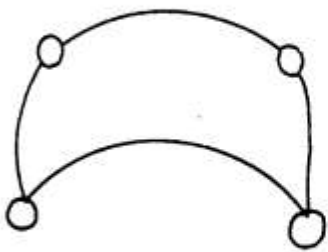
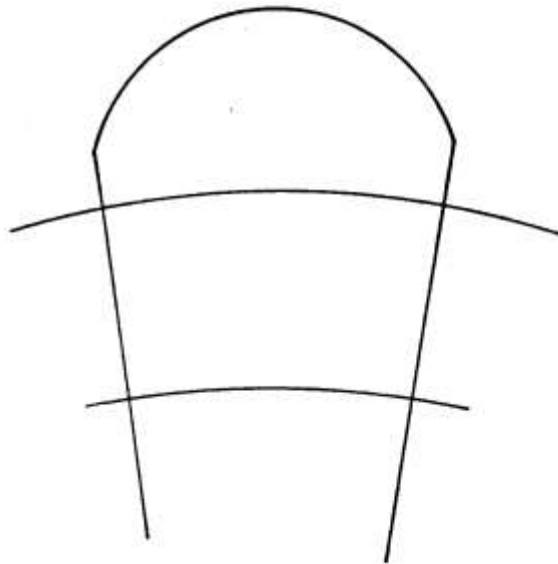
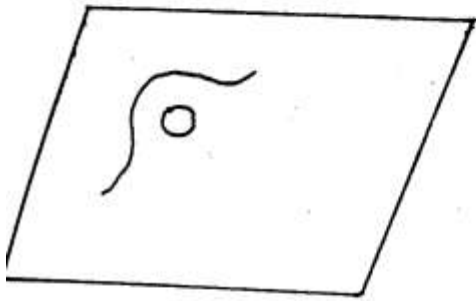
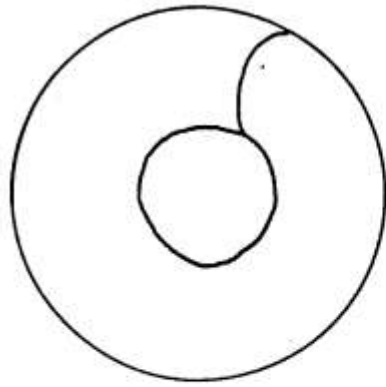
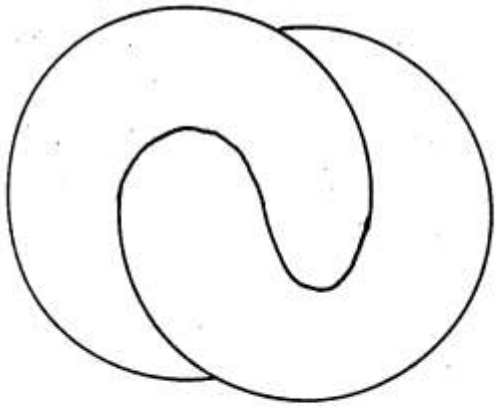

2/. s. i r.

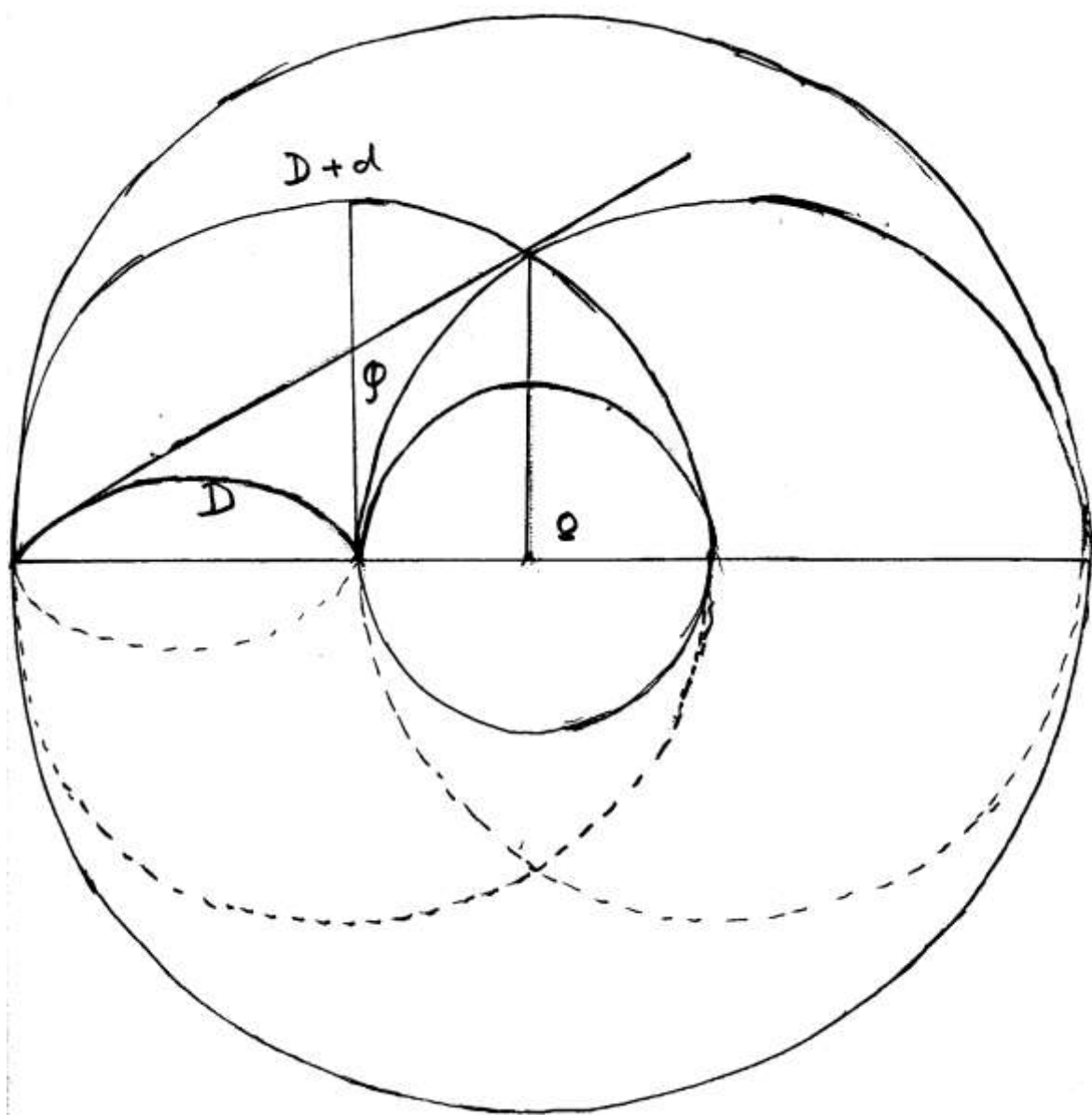

Seminar 15: Wednesday 28 March 1962

Of what use to us is the topology of this surface, of this surface called the torus, in so far as its constituting inflection which makes necessary its turns and returns is what can best suggest to us the law to which the subject is submitted in the processes of identification? This of course will only finally appear to us when we have effectively gone through everything that it represents and how well suited it is to the dialectic proper to the subject in so far as it is a dialectic of identification.

By way of reference therefore and in order that when I highlight one or other point, when I accentuate one or other relief, you may record, as I might say at every moment the degree of orientation, the degree of relevance, of what I am putting forward at that moment with respect to a certain goal that is to be attained, I will tell you that at the limit what can be inscribed on this torus, in so far as it can be of use to us, is going to be symbolised more or less in such a way, that this shape, these circles that are drawn, these letters next to each of these circles, are going to designate it immediately for us. The torus no doubt appears to have a privileged value. Do not think that it is the only form of non-spherical surface that is capable of interesting us; I could not encourage too much those (2) who have some leanings, some gifts for this, to refer to what is called algebraic topology and to the shapes that it proposes to you in something which, if you wish, as compared to classical geometry, the one that you keep written on the seat of your pants because of your passage through secondary education, presents itself exactly as an analogy for what I am trying to do for you on the symbolic plane, what I called an elastic logic, a supple logic. This is still more manifest for the geometry involved. Because the geometry involved in algebraic topology is presented as the geometry of figures which are made of rubber. It is possible that the authors bring into play this caoutchouc, this rubber as they say in English, in order to get across to the listener what is involved; it is a matter of figures which can be deformed and which through all the deformations remain in a constant relationship. This torus is not required to present itself here in its filled-out shape. Do not think that among the surfaces which are defined, which must be defined, the ones that essentially interest us, closed surfaces, in the measure that in any case the subject presents himself as something closed, closed surfaces, however ingenious you may be, you see that there is a

whole field open to the most outrageous inventions. Do not think moreover that imagination lends itself all that willingly to the forging of these supple, complex shapes, which coil around one another and get themselves into knots. You have only to try to accustom yourself to the theory of knots in order to see how difficult it is already to represent for oneself the most simple combinations; this will still not take you far. Because it can be proved that however complicated it may be, you will always be (3) able to reduce any closed surface by means of appropriate procedures to something which cannot go any further than a sphere provided with some appendices, among which precisely those which from the torus are represented here as a handle annexed to, a handle added onto a sphere, as I recently drew it on the blackboard for you, a handle sufficing to transform the sphere and the handle into a torus from the point of view of its topological value.

Therefore, everything can be reduced to the adjunction to the shape of a sphere with a certain number of handles plus a certain number of other eventual shapes.

I hope that in the session before the holidays I will be able to initiate you into this shape which is very amusing - but when I think that the majority of you here do not even suspect its existence! - it is what is called in English a cross-cap or what one can designate by the French word mitre. So, imagine a torus which would have as a property the inversion of its surface at some part of its circuit, I mean that at a place which is put here between two points A and B the outside surface goes through, the surface which is in front goes through the surface which is behind, the surfaces intersect one another. I can only indicate it to you here. This has very curious properties and perhaps even for us rather exemplary ones, in so far as in any case it is a surface which has this property that the outside surface for its part, if you wish, is found to be continuous with the inside face in passing to the inside of the object and therefore can return in one single circuit from the other side of the surface (4) from which it started. It is something very easy to produce in the simplest fashion when you do something with a strip of paper which consists in taking it and twisting it in such a way that its edge is stuck on to the extreme edge after being reversed. You will see that it is a surface which has effectively only a single face, in this sense that something travelling on it never encounters in a certain sense any limit, passes from one side to the other without your being able to grasp at any instant where the conjuring trick has taken place.

Therefore there is here the possibility on the surface of any sphere whatsoever of coming to produce, to simplify any surface however complicated it may be. Let us add here the possibility of holes; you cannot go beyond that, namely that however complicated the surface you imagine may be, I mean for example however complicated the surface you have to make may be, you can never find anything more complicated than that. So that there is a certain naturalness in the reference to the torus as being intuitively the most simple, the most accessible shape.

This can teach us something. In this regard I told you the signification that we could give by convention, by artifice, to two types of circular axis, in so far as they are privileged here. The one which makes the circuit of what one could call the generating circle of the torus, since it is a torus of revolution in so far as it is open to being indefinitely repeated, in some way the same and always different, is well designed to represent for us signifying insistence and especially the insistence of (5) repetitive demand. On the other hand what is implied in this succession of circuits, namely a circularity that is accomplished while at the same time being unnoticed by the subject which is found to offer us an obvious, passive, and in a way maximum symbolisation for intuitive sensibility of what is implied in the very terms of unconscious desire, in so far as the subject follows its highways and byways without knowing it. Throughout all these demands, this unconscious desire is in a way by itself the metonymy of all these demands, and you see here the living incarnation of these references to which I have accustomed you, habituated you throughout my discourse, specifically to those of metaphor and metonymy.

Here, metonymy finds in a way its most tangible application as being manifested by desire in so far as desire is what we articulate as presupposed in the succession of all the demands in so far as they are repetitive. We find ourselves before something where you see that the circle described here merits that we should attach to it the symbol D, qua symbol of Demand. This something involving the inside circle must indeed have something to do with what I will call metonymical desire. Well then, there is among these circles, the test that we can make of it, a privileged circle which is easy to describe: it is the circle which starting from outside the torus finds the means of completing itself, not simply by passing through the central hole, but by enveloping the central hole without for all that passing by the central hole. This circle has the privilege of (6) doing both things at once. It passes through and it envelopes it. It is therefore made up of the addition of these two circles, namely it represents D + d. The addition of demand and desire, allows us to symbolise in a way demand with its underlay of desire.

Why is this of interest? The interest of this is that if we end up at an elementary dialectic, namely that of the opposition between two demands, if it is inside this same torus that I symbolise by another analogous circle the demand of the Other with what that will involve for us of "either..., or...", "either what I demand", "or what you demand", we see this everyday in daily life; this to recall that in the privileged conditions at the level we are going to look for it, to interrogate it, in analysis, it is necessary that we should remember this, namely the ambiguity that there always is in the very usage of the term "either..., or...", this term of disjunction symbolised in logic as: $a \vee b$.

There are two usages of this "either..., or...". It is not for nothing that logic will mark all its efforts and, as I might say.

That the "either..., or..." concerning for example these two circles can mean two things: the choice between one or other of these two circles. But does that mean that simply as regards the position of the "either..., or..." there is exclusion? No, what (7) you see is that in the circle into which I am going to introduce this "either..., or..." there is involved what I can call the intersection symbolised in logic by

The relationship of desire to a certain intersection involving certain laws is not simply called on to put on a matter of fact terrain what one could call the contract, the agreement between demands; given the profound heterogeneity that exists between this field and that one, this is sufficiently symbolised by the following: here we are dealing with the closing of the surface and there properly speaking with its internal void. This puts before us a model which shows us that it involves something other than grasping the part the demands have in common. In other words, it will be a matter for us of knowing in what measure this shape can allow us to symbolise as such the constituent parts of desire, in so far as desire for the subject is this something that he has to constitute along the path of the demand. I am indicating to you already that there are two points, two dimensions that we can privilege in this circle which is particularly significant in the topology of the torus: on the one hand the distance which connects the centre of the central void to this point which is found to be, which can be defined as, a sort of tangency thanks to which a plane intersecting the torus is going to allow us to separate out this privileged circle in the simplest way. This is what will give us the definition, the measure of small o qua object of desire.

On the other hand this, in so far as it is only itself locatable, definable, with respect to the very diameter of this exceptional (8) circle, it is in the radius, in the half if you wish of this diameter, that we see what is the mainspring, the final measure of the relationship of the subject to desire, namely the small qua symbol of the phallus. This is what we are heading towards and what will take on its meaning, its applicability and its import from the path that we will have taken beforehand, in order to allow us to succeed in making this image itself more manageable, tangible for you and up to a certain point suggestive of a truly structural intensity.

This having been said, it is of course understood that the subject, in what we have to deal with in our partner who summons us, in what we have before us in the form of this summons, and what comes to speak before us, only what one can define and punctuate as the subject identifies itself. It is worth recalling that because, after all, it is easy for thinking to drift. Why, if one does not dot the i's, should one not say that the drive identifies itself and that an image identifies itself?

Nothing can correctly be said to identify itself, the term identification is only introduced into Freud's thinking from the moment that one can to some degree, even if this is not articulated in Freud, consider this identification as the dimension of the subject - and that does not mean that this does not take us much further than the subject.

The proof here also - I am reminding you of something about which one cannot know whether it is in the antecedents, the first steps or in the future of my discourse that I highlight it - is that the first form of identification and the one which is referred to (9) with such frivolity, such pitiful parroting is this identification which, we are told, incorporates, or again - adding a confusion to the imprecision of the first formula - introjects. Let us be content with incorporates which is the best. How can one even begin with this first form of identification when not even the slightest indication, not the slightest reference point except a vaguely metaphorical one, is given to you in such a formula about what it can even mean? Or indeed if one speaks about incorporation, it is indeed because something must be happening at the level of the body. I do not know if I can push things far enough this year, I hope so all the same, we have time enough before us to get there, returning to where we began, to give its full meaning and its true meaning to this incorporation of the first identification.

As you will see, there is no other means of bringing it into play except by rejoining it through a thematic which has already been elaborated from the time of the most antique, mythical, indeed religious traditions under the term of "mystical body". Impossible not to take things in a span which goes from the primitive Semitic conception: there is between the age-old father and all those who descend from him a bodily identity, but at the other extreme you know that there is the notion which I have just called by its name, that of the mystical body, in so far as it is from a body that a church is constituted: and it is not for nothing that Freud, to define for us the identity of the ego in its relationships with what he calls on that occasion Massenpsychologie refers to the corporality of the Church.

(10) But how can I make you begin from there without giving rise to all the confusions and make you believe that, as the term mystical sufficiently indicates, it is on quite different paths to those along which our experience would wish to draw us, it is only retroactively, in a way, returning to the necessary conditions of our experience, that we can introduce ourselves to the antecedence suggested by every attempt to tackle in its fullness the reality of identification. Therefore the approach that I chose in the second form of identification is not by chance; it is because this identification is graspable by approaching it by way of the pure signifier, because we can grasp in a clear and rational fashion an angle from which to enter into what is meant by the identification of the subject in so far as the subject brings to birth the unary trait, rather than the unary trait once it has been detached makes the subject appear as one who counts - in the double sense of the term.

The scope for ambiguity that you can give to this formula - the one who actively counts no doubt, but also the one who counts quite simply in reality, the one who really counts, obviously is going to take some time to find where he is in his count, exactly the time that we will take to go through everything that I have just designated for you here - will have for you its full meaning (schema): Shackleton and his companions in the Antarctic

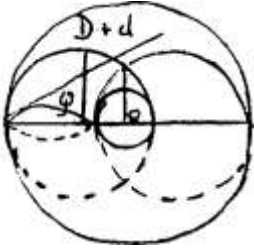

several hundred kilometres from the coast, explorers submitted to the greatest frustration, one which resulted not only from the lacks which were more or less elucidated at the time - because it is a text which is already (11) about fifty years old - from the more or less elucidated lacks in a

special food which was still being tested at that time, but who one might say were disoriented in what I might call a still virgin landscape, not yet inhabited by human imagination, tell us in notes which are very peculiar to read, that they always counted themselves as one more than they were, that they could not make it out: "We were always asking ourselves where the missing person had gone", the missing person who was not missing except because of the fact that their whole effort of counting always suggested to them that there was one more, and therefore one less.

You put your finger here on the appearance in its naked state of the subject who is nothing more than that, than the possibility of one more signifier, of an additional 1 thanks to which he himself notes there is a one who is missing.

If I remind you of this it is simply to highlight in a dialectic which includes the most extreme terms where we situate our path and where you may believe and sometimes even ask yourselves if we are not forgetting certain reference points. You may for example even ask yourselves what relationship there is between the path that I have made you travel and these two terms with which we have had to deal, we have constantly to deal with but at different moments, of the Other and the thing.

Of course, the subject himself in the final analysis is destined for the thing, but his law, more exactly his fatum is this path that he can only describe by passing through the Other in so far (12) as the Other is marked by the signifier, and it is on this side (en deca) of this necessary passage through the signifier that desire and its object are constituted as such. The appearance of this dimension of the Other and the emergence of the subject, I cannot remind you too much of it in order to give you properly the meaning of what is involved and whose paradox, I think, ought to be sufficiently articulated for you in the fact that desire - you should understand it in the most natural sense - can and must constitute itself only in the tension created by this relationship to the Other, which takes its origin from the fact of the advent of the unary trait in so far as at first and since it begins with the thing it always effaces this something which is quite a different thing to this one which has always

been irreplaceable; and we find there from the first step - I point this out to you in passing - the formula, here is where Freud's formula ends: there where the thing was I must come. It should be replaced at the origin by: "Wo Es war, da durch den Ein", rather by "durch den Eins" there by the one qua one, the unary trait, "werde Ich", the "I" will come: the whole path is completely traced out at every point of the path.

It is here indeed that I tried to suspend you the last time by showing you the progress necessary at this moment in so far as it can only be established by the effective dialectic which is accomplished in the relationship with the Other.

I am astonished at the kind of dullness into which it seemed to me there fell my nevertheless carefully worked out articulation of "nothing maybe" and "maybe nothing". What must be done then to make you sensitive to it?

(13) Perhaps precisely my text at this point and the specification of their distinction as message in question, then as response, but not at the level of the question, as suspension of the question at the level of the question, was too complex to be simply heard by those who did not note its detours in order to come back to it. However disappointed I may be it is necessarily I who am wrong, that is why I am coming back to it in order to make myself understood. Will I not suggest to you today for example the necessity at least of coming back to it; and when all is said and done it is simply by asking you: do you think that "nothing sure, rien de sûr", as an enunciating seems to you to give rise to the slightest sliding, to the slightest ambiguity with "surely nothing, sûrement rien"? It is all the same similar. There is the same difference between the "nothing maybe", and the "maybe nothing". I would even say that there is in the first one, the "nothing sure", the same undermining quality of the question at the origin as in the "nothing maybe". And even in the "surely nothing", there is the same power of eventual response no doubt, but always anticipated with respect to the question, as it is easy to put your finger on, it seems to me, if I remind you that it is always before any question and for reasons of security, as I might say, that one learns to say, in life when one is small, surely nothing. That means surely nothing other than what is already expected, namely what one can in advance consider as reducible to zero, like the loops. The non-anxiety-provoking quality of Erwartung, here is what Freud was able to articulate for us on occasion, nothing that we did not know already: when one is like that one is calm, but one is not always so.

(14) So therefore what we see, is that the subject in order to find the thing sets out at first in the opposite direction, that there is no means of articulating these first steps of the subject, except by a nothing which it is important to make you sense in this dimension, at once metaphorical and metonymical, of the first signifying game because every time that we analysts have to deal with this relationship of the subject to the nothing, we slip regularly between two slopes: the common slope

which tends towards a nothing of destruction, the shameful interpretation of aggressivity considered as purely reducible to the biological force of aggression, which is in no way sufficient, except in a degraded way, to support the tendency to nothing as it arises at a certain necessary stage of Freudian thinking in the death instinct just before he introduces identification.

The other, is the nihilisation which could be assimilated to Hegelian negativity. The nothing that I am trying to get to hold together for you at this initial moment in the establishment of the subject is something else. The subject introduces the nothing as such and this nothing is to be distinguished from any ens rationis which is that of classical negativity, from any imaginary being which is that of a being whose existence is impossible, the famous centaur which brings the logicians, all the logicians, indeed the metaphysicians to a halt at the beginning of their path towards science, which is not either the ens privativum, which is properly speaking what Kant admirably in the definition of his four nothings which he turns to such little account, called the nihil negativum, namely to use his own terms: leere Gegenstand ohne Begriff, an empty object, but let us add without concept, (15) without any grasp on it being possible. It is for that reason, to introduce it, that I had to put before you again the network of the whole graph, namely the constitutive network of the relationship to the Other with all its reverberations.

I would like, in order to lead you onto this path, to pave your way with flowers. I am going to try it today, I mean to mark my intentions when I tell you that it is starting from the problematic of the beyond of the demand that the object is constituted as object of desire; I mean that it is because the Other does not answer, except with "nothing maybe", that the worst is not always sure, that the subject is going to find in an object the very virtues of his initial demand. You should understand that it is in order to pave your way with flowers that I am recalling these truths of common experience whose signification is not sufficiently recognised, and try to make you sense that it is not by chance, analogy, comparison, nor just flowers but profound affinities which will make me indicate to you at the end the affinity of the object with this Other - with a big 0 - in so far for example as it manifests itself in love, that the famous speech of Eliante in Le Misanthrope is taken from the De natura rerum of Lucretius:

"The palefaced lady's lily white, perforce;
The swarthy one's a sweet brunette of course;
The spindly lady has a slender grace;
The fat one has a most majestic pace;
The plain one, with her dress in disarray,
They classify as beaute negligee..."

(16) It is nothing other than the impossible-to-efface sign of this fact that the object of desire is only constituted in the relationship to the Other in so far as it takes its origin itself

from the value of the unary trait. There is no privilege in the object except in this absurd value given to each trait of being a privilege.

What else is still necessary to convince you of the structural dependency of this constitution of the object (object of desire) on the initial dialectic of the signifier, in so far as it runs aground on the non-response of the Other, if not the path we have already taken of Sadian research which I showed you at length - and if it is lost, you should know at least that I have committed myself to going back on it in a preface that I promised for an edition of Sade - we cannot overlook with what I am calling here the structuring affinity of this journey towards the Other in so far as it determines any setting up of the object of desire; that we see in Sade at every moment mingled, woven together with one another, invective - I mean invective against the Supreme Being, his negation being only a form of invective even if it is the most authentic negation - absolutely interwoven with what I would call, in order to approach it, to tackle it a little, not so much the destruction of the object as what we could take first of all for its simulacrum because you know the exceptional resistances of the victims of the Sadian myth to all the trials which the romantic text puts them through. And then what, what is meant by this sort of transference onto the mother incarnated in nature of (17) a certain and fundamental abomination of all her acts? Should this dissimulate from us what is involved and what we are told nevertheless is involved in imitating her in his acts of destruction and by pushing them to the final term by a will applied to forcing her to recreate something else, which means what? Giving his place back to the creator.

When all is said and done in the final analysis, Sade said it without knowing it, he articulates this by his enunciating: I am giving you your abominable reality, you the father, by substituting myself for you in this violent action against the mother. Of course, the mythical returning of the object to nothing is not simply aimed at the privileged victim, who is when all is said and done adored as object of desire, but the very million-fold multitude of everything that there is. Remember the anti-social plots of Sade's heroes. This returning of the object to nothing essentially simulates the annihilation of signifying power. This is the other contradictory term of this fundamental relationship to the Other as it is established in Sadian desire, and it is sufficiently indicated in the final testamentary wish of Sade in so far as it is aimed precisely at this term which I specified for you of the second death, the death of being itself in so far as Sade in his will specifies that of his tomb and intentionally of his memory despite the fact that he is a writer there should literally remain no trace and a thicket ought to be regrown over the place where he is inhumed, that of him essentially as subject it is the no traces which indicates where he wants to affirm himself: very precisely as what I called the annihilation of the signifying power.

(18) If there is something else that I have to remind you of here to sufficiently punctuate the legitimacy of the necessary

inclusion of the object of desire in this relationship to the Other in so far as it implies the mark of the signifier as such, I will designate it for you less in Sade than in one of the most sensitive recent, contemporary, commentaries of him, indeed the most illustrious of them. This text which appeared immediately after the war in an issue of Les Temps Modernes, recently re-edited through the efforts of our friend Jean-Jacques Pauvert in the new edition of the first version of Justine, is the preface by Paulhan. We cannot be indifferent to such a text, in so far as you follow here the detours of my discourse; because it is striking that it is by the simple paths of rhetorical rigour - you will see that there is no other guide to the discourse of Paulhan, the author of Fleurs de Tarbes - I mean that the ever so subtle separating out by him in this way of everything that had been articulated up to the present on the subject of the signification of Sadianism, namely what he calls the "complicitousness of the Sadian imagination with its object", namely the view from the outside, I mean through the approach that can be made of it by a literal analysis, the surest view, the strictest one that one can give to the essence of masochism, of which precisely he says nothing except that he makes us sense very clearly that it is along this path, that this is the last word on Sade's approach, and not to judge it clinically and in a way from outside where nevertheless the result is manifest. It is difficult to better offer oneself to all the mistreatment of society than Sade did at every instant, but this is not the essential thing, the essential thing being suspended in this text (19) of Paulhan, which I would ask you to read, which proceeds by way of a rhetorical analysis of the Sadian text to make us sense, only behind a veil, the point of convergence in so far as it situates itself in this quite obvious reversal founded on the most profound complicity with that of which the victim here is when all is said and done only the symbol marked by a sort of substance absent from the ideal of Sadian victims. It is as object that the Sadian subject cancels himself out, by means of which effectively he rejoins what appears to us phenomenologically then in the texts of Masoch, namely that the end, that the high point of masochistic jpuissance is not so much in the fact that it offers itself to support or not one or other bodily pain, but in this extreme particularity that namely in the books you will always find in the small or big texts of the masochistic phantasmagoria, this cancelling out properly speaking of the subject in so far as he makes himself pure object. There is no end to this except the moment when any masochistic novel whatsoever, arrives at this point which from the outside may appear so superfluous, indeed a de luxe embellishment, which is properly speaking that this masochistic subject forges himself as being the object of a bargaining or very exactly of a sale between the two others between whom he is passed like a property, a venal property - and you should note not a fetish - because the final term is indicated in the fact that he is a vile piece of cheaply sold stuff that there would be no reason even to preserve as an antique slave who at least constituted himself, imposed respect for himself, by his market value.

(20) All this, these detours, this path paved with the flowers of

Tarbes precisely or literary flowers, in order to mark clearly for you what I mean when I talk about what I have accentuated for you: namely the profound perturbation of jouissance, in so far as jouissance is defined with respect to the thing, by the dimension of the Other as such in so far as this dimension of the Other is defined by the introduction of the signifier.

Just three more little steps forward and then I will put off to the next time the rest of this discourse lest you may become too aware of the fluey fatigue that is hanging over me today.

Jones is a curious personage in the history of analysis: as regards the history of analysis what he impresses on my mind, I will tell you immediately to continue this path of flowers today, is what diabolical wish to dissimulate there must have been in Freud for him to have entrusted the task of writing his own biography to this cunning and therefore short-sighted Welshman, so that he would not go too far in the work that was entrusted to him. It is there in the article on symbolism which I devoted to the work of Jones, which does not simply signify the desire to close my article with something clever, what that on which I concluded signifies, namely the comparison between the activity of the wily Welshman and the work of a chimney sweep. In effect he swept all the tubes very well and I can be accorded this credit that in the aforesaid article I followed him through all (21) the detours of the day's work until I emerged with him completely black through the door that opens out onto the salon, as you remember maybe. Something which earned me from the part of another eminent member of the analytic Society, one of those whom I best appreciate and love, another Welshman, the assurance in a letter that he really did not understand in any way the utility that I apparently believed was to be found in this scrupulous approach.

Jones never did any more in his biography to mark all the same a little his distance than to bring a little light from outside, namely the points where the Freudian construction is found to be in disaccord with, in contradiction with the Darwinian gospel, which is quite simply on his part a really grotesque manifestation of chauvinistic superiority.

Jones therefore, in the course of a work whose progress is fascinating by reason of its very miscognitions, especially in connection with the phallic stage and his exceptionally plentiful experience of female homosexuals, Jones encounters the paradox of the castration complex which constitutes undoubtedly the best of all the things to which he adhered - and did well to adhere to - to articulate his experience in which literally this was the only thing he ever penetrated. The proof is the introduction of this term, which is certainly handy provided one knows what to make of it, namely that one knows how to spot in it what must not be done in order to understand castration: the term aphanisis. To define the meaning of what I can call here without forcing anything the Oedipal effect, Jones tells us something which could not be (22) better situated in our discourse: here he finds himself, whether he wants to or not, sharing the notion that the Other, as

I articulated for you the last time, prohibits the object or the desire. My "or" is or seems to be exclusive. Not altogether: "either you desire what I desired, I the dead God, and there is no other proof - but it is enough - of my existence than this commandment which prohibits its object to you"; it constitutes it precisely in the dimension of the lost: "You can no longer, whatever you do, do anything but find another, never that one". It is the most intelligent interpretation that I can give to this step that Jones takes so lightly - and I assure you with drums playing - when it is a matter of marking the entrance of these homosexuals into the sulphurous domain which from then on will be their habitat: either the object or the desire, I assure you that there is no delay about it.

If I dwell on it, it is in order to give to this choice: "vel... vel...", the best interpretation, namely that I add to it, I am allowing my interlocutor to speak in the best way possible. "Either you renounce desire", Jones tells us. When one says it quickly it may seem to be self-evident, in the measure that previously our soul and at the same time our understanding had been given an opportunity to relax by translating castration for us as aphanisis. But what does it mean to renounce desire? Is it all that tenable, this aphanisis of desire, if we give it this function that it has in Jones, of being a subject of fear.

Is it even conceivable first of all in the experiential fact, at (23) the point that Freud brings it into play - and I grant it to him - in one of the possible exemplary outcomes of the Freudian conflict, that of the female homosexual? Let us look closely at it. This desire which disappears, which you as subject renounce, does our experience not teach us that this means that henceforth your desire is going to be so well hidden that it can appear to be absent for a while? Let us even say that like our cross-cap or mitre surface, it is inverted in the demand. The demand here, once again, receives its own message in an inverted form. But in the final analysis, what does this hidden desire mean if not what we call and discover in experience as repressed desire? There is only one thing in any case that we know very well we will never find in the subject: it is the fear of repression as such, at the very moment that it is operating, when its happening. If in aphanisis something which concerns desire is involved, it is arbitrary given the way that our experience teaches us to see it concealing itself.

It is unthinkable that an analyst should articulate that there can be formed in consciousness something which is supposed to be the fear of the disappearance of desire. Where desire disappears, namely in repression, the subject is completely included in, not detached from this disappearance. And we know it: anxiety, if it is produced, is never about the disappearance of desire, but of the object that it dissimulates, of the truth of desire, or if you wish again of what we do not know about the desire of the Other. Every questioning by consciousness about desire as being able to lose strength can only be complicituous. Consci moreover means accomplice, which is something here in (24) which etymology takes on its freshness again from experience

and it is indeed for that reason that I reminded you earlier in my path paved with flowers about the relationship between the Sadian ethics and its object. This is what we call ambivalence, ambiguity, the reversibility of certain instinctual (pulsionnels) couples, but all we see by simply saying that about this equivalent, is this turning back on itself, the subject becoming object and the object subject. We do not grasp the true mainspring of it which always implies this reference to the big Other where all of this takes on its meaning.

Therefore aphanisis explained as source of the anxiety in the castration complex is properly speaking an exclusion of the problem; because the only question that an analytical theorist has to pose here - and one understands very well that he has in effect to pose a question, because the castration complex remains up to the present a reality which is not completely elucidated - the only question that he has to pose himself is the one that begins from the fortunate fact that thanks to Freud who bequeathed his discovery to him at a much more advanced stage than the point to which he, the analytical theorist, can get to, the question is to know why the instrument of desire, the phallus, takes on such a decisive value, why it is it and not desire which is implicated in anxiety, in a fear about which it is all the same not vain that we have testified, as regards the term aphanisis, in order not to forget that every anxiety is an anxiety about nothing, in so far as it is from the "nothing maybe" that the subject has to barricade himself, which means that for a time, it is the best hypothesis for him: nothing (25) maybe to fear. Why is it here that the function of the phallus emerges, here where in effect without it everything would be so easy to understand, unfortunately in a fashion altogether outside experience? Why the phallus thing, why does the phallus come as a measure at the moment when it is a question of what? Of the void included at the heart of the demand, namely of the beyond of the pleasure principle, of that which makes of the demand its eternal repetition, namely of what constitutes the drive. Once more we are brought back to this point which I will not go beyond today that desire is constructed on the path of a question which menaces it and which belongs to the domain of not being (n'etre), which you will allow me to introduce here with this play on words. A final reflection was suggested to me lately with the every day presentation of the way in which it would be appropriate to articulate honestly, and not simply by sniggering, the eternal principles of the Church and the vacillating detours of different national laws about birth control, namely that the first raison d'etre, which no legislator has up to the present taken into account for the birth of a child, is that one desires it and that we who know well the role of this - whether it was or was not desired - on the whole development of the subsequent subject, it does not seem that we have felt the need to recall it, to introduce it, to make it understood throughout this drunken discussion which oscillates between obvious utilitarian necessities of demographic policy and the anxiety provoking fear - let us not forget it - of the abominations that eugenics eventually promise us.

It is a first step, a tiny little step, but an essential step - and you will see how much it needs to be tested - deciding (26) between such a possibility of choosing, to point out the constitutive effective relationship in any future destiny to be respected as it were as the essential mystery of the being who is to come that he should have been desired and why.

Remember that it often happens that the basis of the desire of a child is simply the fact that nobody says: that he should be a not one, that he should be my curse on the world.

Seminar 16: Wednesday 4 April 1962

Those who for diverse reasons, personal or other, distinguished themselves by their absence from what we call the provinciale meeting of the Society are going to have to put up with a little aside; because for the moment, it is to the others that I am going to address myself, in so far as I owe them a debt, an agreeable sort of debt. Perhaps they may have suspected it, because I said something at this little congress. This was to defend the position they had taken up and I must admit that on my part this masked a certain dissatisfaction with them.

One must all the same philosophize a bit about the nature of what is called a congress. In principle, it is one of these sorts of meetings at which people speak, but at which everyone knows that something he is saying has some element of bad taste about it, so that it is quite natural that nothing is said there except pompous nothings, each one ordinarily remaining locked in the role he has to protect.

This is not altogether what happens at what we more modestly call our Journees. But for some time everyone is very modest. They are called conferences, meetings. This changes nothing... at bottom they always remain congresses.

(2) There is the question of rappports [reports, relationships]. It seems to me that it is worth while dwelling on this term because after all it is rather amusing when one looks closely at it: rapport to what, about what, rapport between what, even indeed rapport against what, as when one talks about an informer (rapporteur). Is this really what is meant? We would have to see. In any case if the word rapport is clear when one says: "The report of Mr So-and-so on the financial situation", one cannot all the same say that one is completely at ease in giving what should be an analogous meaning to a term like a "report on anxiety" for example. You must admit that it is rather curious to be giving a report on anxiety, or on poetry for that matter, or on a certain number of terms of this type. I hope all the same that the strangeness of the thing is obvious to you, and that it specifies not simply congresses of psychoanalysts, but a certain number of other congresses, let us say, of philosophers in general.

The term report, I must say, makes one hesitate; moreover at one time, I myself did not hesitate to describe as a discourse what I

had to say about analogous terms: "Discourse on psychic causality", for example. That looks a bit precious. I came back to report like everyone else.

All the same this term and its usage are there to make you pose the question precisely about the degree of appropriateness against which these strange rapports with their alien objects are measured. It is quite certain that there is a certain proportion between these aforesaid reports and a certain constitutive type of the question to which it refers: the void at the centre of my torus for example is very tangible when we (3) are dealing with anxiety or desire. Which should allow us to believe, to understand, that the best signifying echo that we could have of the term scientific rapport on this occasion, might be with what is also called rapport when we are dealing with sexual relationships; both one and the other are not without a rapport to the question we are dealing with, but only just.

It is here indeed that we rediscover this dimension of the "not without", (pas sans), as grounding the very point at which we are introduced into desire and in so far as access to desire requires that the subject should not be without having it. Having what? That is the whole question. In other words, that access to desire resides in a fact, in the fact that the covetousness of the being who is called human must be inaugurally depressed in order to be restored to the echelons of a power of which there is question as regards what it is, but above all, towards what this power is exerting itself. Now obviously, tangibly, it seems that what it is exerting itself towards throughout all the metamorphoses of human desire, is something always more tangible, more specified which is grasped by us as this central hole, this thing which it is ever more necessary to turn around in dealing with this desire that we know, this human desire in so far as it is more and more unformed. This is what makes it legitimate therefore up to a certain point that their reports, that of the report on anxiety in particular the other day, could only accede to the question by being not without a rapport to the question.

(4) This does not mean all the same that the "without", as I might say, should get too far ahead of the "not", in other words that one may believe a little bit too easily that one can respond to the constitutive void at the centre of a subject by an excessive poverty in the means of approaching it; and here you will allow me to evoke the myth of the foolish virgin which, in the Judaeo-Christian tradition, corresponds so nicely to that of Penia, of extreme poverty, in Plato's Symposium. Penia succeeds in her efforts because she knows about Venus; but it is not necessarily so: the improvidence that the aforesaid foolish virgin symbolises may very well make her miss becoming pregnant.

Now, where is the unforgiveable limit in this affair - because after all this indeed is what is involved: it is the style of what can be communicated in a certain mode of communication that we are trying to define, the one which forces me to come back to anxiety here not in order to admonish nor to lecture those who spoke, not without some faltering - the limit obviously being

sought, from which one can reproach congresses in general about their results, where is it to be sought? Because we are speaking about something which allows us to grasp its void when it is a matter for example of speaking about desire; are we going to look for it in this sort of sin in desire against some fire or other of passion, of the passion for truth for example, which is the mode onto which we could very well pin for example a certain manner, a certain style: the university manner for example? This would be altogether too convenient, it would be much too easy.

(5) I am certainly not going to parody here the famous roar of the vomiting of the Eternal Being before a mediocre lukewarmness, a certain kind of heat ends just as well - as we know - with sterility. And in truth, our morality, a morality which already holds up very well, Christian morality, says that there is only one sin: the sin against the spirit. Well then, we for our part are saying that there is no sin against desire, any more than there is a fear of aphanisis, in the sense that Mr Jones understands it. We cannot say in any case that we can reproach ourselves for not desiring well enough. There is only one thing - and this we can do nothing about - there is only one thing to be dreaded: it is an obtuseness in recognising the curve proper to the progress of this infinitely flat being whose necessary propulsion I demonstrate for you on this closed object which I am here calling the torus, which is in truth only the most innocent shape that the aforesaid curve can take on since in another different shape which is no less possible nor less widespread, it is in the very structure of these shapes to which I introduced you a little the last time, that the subject in displacing himself finds himself with his left placed on the right and this without knowing how it could have happened, how it came about. In this respect, all those who are listening to me here are not privileged in this respect about this; nor am I, I would say, up to a certain point; that can happen to me just as it happens to others.

The only difference between them and me up to the present, it seems to me, lies in the work that I put into it in so far as I give a little bit more to it than they do.

I may say that in a certain number of things which were advanced (6) on a subject that no doubt I have not tackled at all: anxiety - this is not what decided me to announce to you that it will be the subject of my seminar next year, if the times we live in will allow there to be one - on this subject of anxiety I heard many strange things, risky things, not all erroneous, that I would not have to reprove, addressing myself specifically to one or other of them, one at a time. It seemed to me nevertheless that what was revealed there in terms of a certain weakness was indeed that of a without (sans) and not at all of a nature to encompass what I call the void of the centre. All the same some remarks from my last seminar should have put you on your guard about the most pertinent points; and it is for this reason that it appears to me just as legitimate to tackle the question from this angle today because this links on exactly to last week's discourse. It is therefore all the same not for nothing that in it I put the

accent on, recalled, the distance that separates in our fundamental coordinates, those into which there must be inserted our theorems about identification this year, the distance that separates the Other from the thing, nor indeed that in explicit terms I believed I had to highlight for you the relationship between anxiety and the desire of the Other.

For want really of starting from there, of hanging on to this as a sort of firm handle and for having only circled around it because of some shame or other - because really at certain moments, I would say almost all the time and even in these reports of which I spoke - for some reason or other which comes from this sort of lack which is not the right one, even in these reports all the same you can connote in the margin this something (7) or other which was always the convergence imposing itself with the kind of orientation of a compass needle, that the only term which could give a unity to this sort of oscillating movement around which the question hesitated, was this term: the relationship of anxiety to the desire of the Other; and this is what I wanted, because it would be false, vain, but not without risk not to mark here something in passing which might be like a germ to prevent all the interesting things that no doubt were said throughout the hours of this little meeting at which more and more accentuated things came to be enounced, in order that this should not be dissipated, in order that this should be linked up with our work, allow me to try here very massively, in the margin as it were and almost in advance but also not without a relevance to exact points, at the point that we had arrived at to punctuate a certain number of primary guiding points, without the reference, which should never be lacking to you at any moment.

If the fact that a fundamental access to jouissance qua jouissance of the thing is prohibited, if this is what I told you throughout the whole year of the seminar on Ethics, if it is in this suspension, in the fact that this jouissance is aufgehoben, suspended properly speaking that there lies the supporting plane on which desire is going to be constituted as such and be sustained - because it is really the most distant approximation from anything that the world may say - do you not see that we can formulate that the Other, this Other in so far as it at once poses itself as being and is not, that it is to be, when we advance towards desire we clearly see that the Other here in as (8) much as its support is the pure signifier, the signifier of the law, that the Other is presented here as a metaphor of this prohibition. To say that the Other is the law or that it is jouissance qua prohibited, is the same thing. So then, an alert to the person - who moreover is not here today - who made of anxiety the support and the sign and the spasm of the jouissance of a self identified, identified exactly as if he were not a pupil of mine with this ineffable foundation of the drive as if it were the heart, the centre of being where precisely there is nothing. Now everything that I teach you about the drive is precisely that it is not to be confused with this mythical self, that it has nothing to do with what has been made of it from a Jungian perspective. Obviously, it is not common to say that

anxiety is the jpuissance of what one could call the final foundation of one's own unconscious. This was what this discourse depended on. It is not common and it is not because it is not common that it is true. It is an extreme to which one can be brought when one is in a certain error which entirely reposes on the elision of this relationship of the Other to the thing as antinomial; the Other is to be, therefore it is not, it has all the same some reality, without that I could not even define it as the locus where the signifying chain is unfolded, the only real Other because there is no Other of the Other, nothing which guarantees the truth of the law, the only real Other being what one can enjoy without the law. This virtuality defines the Other as locus: the thing in short elided, reduced to its place, this is what the Other with a big O is. And I am going right away very quickly to what I have to say about anxiety: this passes, as I announced to you, through the desire of the Other. So then (9) this is where we are at with our torus, it is here that we have to define it step by step. It is here that I will carry out a first examination a little too quickly: this is never a bad thing because one can come back on it.

First approach: are we going to say that this relationship that I am articulating in saying that the desire of man is the desire of the Other, something which of course means something, but now what is in question, what that already introduces is that obviously I am saying something completely different. I am saying that the desire x of the ego subject is the relationship to the desire of the Other, is supposed to be with respect to the desire of the Other in a relationship of beschränkung, of limitation, is supposed to become configured in a simple field of vital space or not, conceived as homogeneous, is supposed to come to limit itself by their colliding with one another. A fundamental image of all sorts of thoughts when one is speculating on the effects of a psycho-sociological conjunction. The relationship of desire to the subject, of the subject to the desire of the Other has nothing to do with anything whatsoever that can be intuitively supported from this register.

A first step would be to advance that if measure means a measure of size, there is no common measure between them and simply by saying that, we rejoin experience. Who has ever found a common measure between his desire and anyone whom he has had to deal with as desire? If one does not put that first in any science of experience, when one has Hegel's title, the real title of the Phenomenology of the spirit, one can permit oneself anything, including the delirious sermonising about the benefits of genitality. It is this and nothing other which is meant by my introduction of the symbol 41, it is something designed to suggest to you that $J-1$ multiplied by $J-1$, the product of my (10) desire by the desire of the Other only gives and can only give a lack: -1 , the want of the subject at this precise point:
 $\sqrt{-1} \times j-1 = -1$. Result: the product of one desire by the other one can only be this lack, and it is from that that one must start in order to hold onto something. This means that there cannot be any agreement, any contract on the plane of desire, that what is involved in this identification of the desire of man

to the desire of the Other, this is what I will show you in an open operation by making the puppets of the phantasy operate for you in so far as they are the support, the only possible support for what can be in the proper sense a realisation of desire. Well then, when we have arrived there - you can already all the same see indicated in a thousand references: the references to Sade to take those which are closest, the phantasy: "A child is being beaten", to take one of the first angles with which I began to introduce this operation - what I will show is that the realisation of desire signifies, in the very act of this realisation, can only signify being the instrument, serving the desire of the Other who is not the object that you have before you in the act but another who is behind.

It is a matter here of the possible term in the realisation of the phantasy, it is only a possible term and before making yourselves the instrument of this Other in a hyper-space, you have well and truly to deal with desires, with real desires. Desire exists, is constituted, makes its way through the world and exercises its ravages before any attempt of your erotic (11) or other imaginings to realise it; and it is even not excluded that you might encounter the desire of the Other as such, of the real Other as I defined it earlier.

It is at this point that anxiety is born; anxiety is as stupid as a cabbage. It is unbelievable that at no time did I even see the outline of something so simple in what seemed at certain moments, as they say, to be a game of hide-and-seek. People went looking for anxiety, and more exactly what is more original than anxiety: pre-anxiety, traumatic anxiety. No one spoke about this: anxiety is the sensation of the desire of the Other. Except that, as of course every time someone advances a new formula, I do not know what happens, the preceding ones find their way to the bottom of your pockets and never come out again. It is necessary all the same for me to image this - I apologise for it - and that in a gross way to get across what I mean, allowing you after that to try to make use of it, and this can be of use wherever there is anxiety.

A little apologue which is perhaps not the best one. The truth is that I made it up this morning, telling myself that I would have to try to make myself understood. Usually I make myself understood inexactly, which is not such a bad thing; this avoids you making mistakes in the right place. I am going to try to make myself understood in the right place and avoid you making an error: imagine me in an enclosed area alone with a praying mantis three metres high - it is the proper proportion for me to be the (12) same size as the aforesaid male, and furthermore I am dressed in a skin the size of the aforesaid male which is 1m 75cm high, more or less my own. I look at myself, I look at my image decked out in this way in the faceted eye of the aforesaid praying mantis. Is this anxiety?

It is very close to it. Nevertheless in telling you that it is the sensation of the desire of the Other, this definition shows itself for what it is, namely purely introductory. You must

obviously refer to my structure of the subject, namely know all the preceding discourse in order to understand that if it is the Other with a big O that is involved, I cannot be satisfied with not going any further by only representing in the affair this little image of myself as a male mantis in the faceted eye of the Other. It is properly speaking the pure apprehension of the desire of the Other as such that is involved if precisely I fail to recognise what? My insignia: namely that I am decked out in the skin of the male. I do not know what I am as object for the Other. Anxiety, it is said, is an affect without object but we have to know where this lack of object is: it is on my side. The affect of anxiety is in effect connoted by a want of object, but not by a want of reality. If I no longer know myself as eventual object of this desire of the Other, this Other who is before me, its figure is entirely mysterious to me in the measure especially that this shape as such which I have before me cannot in effect be constituted for me either as object, but where all the same I can sense sensations of a type which make up the whole substance of what is called anxiety, of this unspeakable oppression through (13) which we arrive at the very dimension of the locus of the Other in so far as desire can appear there.

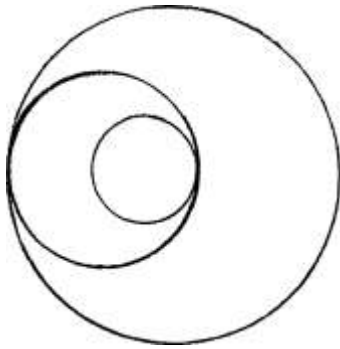

That is what anxiety is. It is only starting from there that you can understand the different angles the neurotic takes to manage in this relationship with the desire of the Other. Now, at the point that we are at, I showed you the last time this desire as necessarily included in the demand of the Other. Here moreover what do you rediscover as a primary truth if

not a commonplace of daily experience? What is anxiety-provoking for someone, not just for small children, but for the small children that we all are, is what can indeed be hidden in any demand in terms of this x , of this impenetrable and anxiety-provoking x par excellence of the "what can he want in this situation?" You can clearly see what the configuration here demands, you can clearly see: it is a middle term between demand and desire. This middle term has a name, it is called the phallus. The phallic function has absolutely no other meaning than to be what gives the measure of this field to be defined within the demand as the field of desire, and moreover, if you wish, that everything that analytic theory, Freudian doctrine, tells us about this consists precisely in telling us that it is through this when all is said and done that everything is arranged.

I do not know the desire of the Other: anxiety, but I know its instrument: the phallus, and whoever I am, I am requested to pass this way and not to make a fuss; which is called in everyday (14) language continuing on daddy's principles; and since everyone knows that for some time now daddy no longer has any principles, this is where all the trouble begins; but as long as daddy is there in so far as he is the centre around which there is organised the transference of what is in this matter the

unit of exchange, namely: I mean the unit which is established, which becomes the basis and the principle of every support, of every foundation, of every articulation of desire, well then, things can carry on, they will be exactly stretched between the mephunai, "would that he had never begotten me!" at the limit and what is called the baraka in the Semitic and even properly speaking biblical tradition, namely the contrary, what makes me the living, active prolongation of the law of the father, of the father as origin of what is going to be transmitted as desire.

You are going to see here that castration anxiety therefore has two meanings and two levels; because if the phallus is this element of mediation which gives its support to desire, well then the woman is not the worst off in this affair because after all for her it is quite simple: because she does not have it, she only has to desire it; and indeed in the most successful cases, it is in effect a situation to which she adapts very well. The whole dialectic of the castration complex in so far as for her it introduces the Oedipus complex, as Freud tells us, means nothing other than that. Thanks to the very structure of human desire, the path for her requires fewer detours - the normal path - than for the man. Because for the man, in order that his phallus may serve as this foundation of the field of desire, is it going to (15) be necessary for him to demand it in order to have it? It is indeed something like that that is involved at the level of the castration complex, a transitional passage from what in him is the natural, become semi-alien, vacillating support of desire through this habilitation by the law, by means of which this piece, this pound of flesh is going to become the pledge, the something through which he is going to designate himself at the place where he has to manifest himself as desire within the circle of demand. This necessary preservation of the field of demand which through the law humanises the mode of relationship of desire to its object is what is involved at this point and is what means that the danger for the subject is not, as is said in all these deviations that we have been making for years to try to contradict analysis, that the danger for the subject is not in any abandonment on the part of the Other, but in his abandonment as subject to the demand. Because in as much as he lives, as he closely develops the constitution of his relationship to the phallus in the field of the demand, it is here that this demand does not properly speaking have any term: because again even though it is necessary, as you know, for this phallus to be demanded in order to introduce, to establish this field of desire, it is not properly speaking in the power of the Other to make a gift of it on the plane of demand. It is in the measure that therapeutics does not at all manage to resolve better than it has done the ending of analysis, does not manage to make it emerge from the proper circle of demand, that it comes up against, that it finally ends up in this demanding form, in this unsatisfiable, unendliche form that Freud in his final article, "Analysis terminable and interminable", designates as unresolved (16) anxiety about castration in the case of the man, as Penisneid in the woman. But an exact positioning, a correct positioning of the function of demand in analytic efficacy and

the fashion of directing it might perhaps allow us, if we were not so backward about it, a backwardness already sufficiently designated by the fact that obviously it is only in the rarest cases that we come up against this term marked by Freud as the end point of his own experience. Would to heavens we could arrive at this point even if it is only an impasse! This would at least prove how far we could go, while what is involved, is to know effectively if going that far leads us to an impasse or whether one can go further.

Before leaving you must I indicate to you some of the little points which will give you satisfaction because they show you that we are in the right place by referring ourselves to something which exists in our experience of the neurotic? What for example does the hysteric or the obsessional neurotic do in the register that we have been trying to construct, what do both one and the other do with regard to the desire of the Other as such?

Before we fell into their snare by encouraging them to play out the whole game on the plane of demand, by imagining to ourselves - which moreover is not an absurd thing to imagine - that we will manage at the limit to define the phallic field as the intersection of two frustrations, what do they do spontaneously?

(17) For the hysteric it is quite simple; for the obsessional also, but it is less obvious. The hysteric does not need to have attended our seminar in order to know that man's desire is the desire of the Other and that as a consequence, the Other can perfectly well, in this function of desire, supply for her the hysteric. The hysteric lives her relationship to the object by fomenting the desire of the Other with a big O for this object. Consult Dora's case. I think that I have already sufficiently articulated this per longum et latum not to even need to recall it here. I appeal simply to the experience of each one of you and to what are called the operations of subtle plotting that you can see being developed in the whole behaviour of the hysteric which consists in sustaining in her immediate environment the love of one or other person for somebody else who is her friend and the true final object of her desire, the profound ambiguity always remaining of course of knowing whether the situation ought not to be understood in the reverse direction.

Why? This is what of course you will be able to see in the continuation of our remarks as perfectly calculable from the simple fact of the function of the phallus which here can always pass from one to the other of the hysteric's two partners.

But we will come to this in detail. And what does the obsessional really do concerning, I am speaking directly, his business with the desire of the Other? It is more astute because moreover this field of desire is constituted by the paternal demand in so far as it is what preserves, what defines the field of desire as such by prohibiting it. Well then, let him sort it (18) out for himself therefore, the one who is charged with

sustaining desire with respect to the object in obsessional neurosis: the dead person. The subject has the phallus, he may even exhibit it on occasion, but it is the dead person who is asked to make use of it. It is not for nothing that I highlighted the story in the Ratman, the nocturnal hour when having contemplated his erection at length in the mirror he goes to the entrance door to open it to his father's ghost, to ask him to recognise that everything is ready for this supreme narcissistic act that this desire is for the obsessional.

Except for this do not be surprised that with such means anxiety only appears from time to time, that it is not there all the time, that it is even much more and much better set aside in the hysteric than in the obsessional, the complacency of the Other all the same being much greater than that of a dead person whom it is always difficult all the same to maintain present as one might say. This is why the obsessional from time to time, every time there cannot be repeated to satiety the whole arrangement which allows him to manage the desire of the Other, sees re-emerging of course in a more or less overwhelming fashion the affect of anxiety. From this simply by returning backwards, you can understand that the phobic business marks a first step in this attempt which is properly speaking the neurotic mode of resolving the problem of the desire of the Other, a first step, I am saying, of the way in which this can be resolved. It is a step as everyone knows, for its part, which is of course far from arriving at this relative solution of the anxiety relationship.

(19) Quite the contrary, it is only in an altogether precarious fashion that this anxiety is mastered, as you know, through the mediation of this object whose ambiguity between the small o function and the small function is already sufficiently underlined for us. The common factor which the small constitutes in every small o of desire is here in a way extracted and revealed. It is on this that I will put the accent the next time by beginning again from phobia, in order to specify what exactly this function of the phallus consists in.

Today in general what do you see? It is that when all is said and done the solution that we perceive to the problem of the relationship of the subject to desire at its radical foundation, is proposed as follows: because it is a question of demand and it is a question of defining desire, well then let us say roughly: the subject demands the phallus and the phallus desires. It is as stupid as that. It is from that at least that one must begin as a radical formula to see effectively what is to be made of it in experience. This model is modulated around this relationship of the subject to the phallus in so far as, as you see, it is essentially of an identificatory nature and that if there is something which effectively can provoke this arousal of anxiety linked to the fear of a loss, it is the phallus. Why not desire? There is no fear of aphanisis, there is the fear of losing the phallus because only the phallus can give its proper field to desire.

But now let no one speak to us either about defence against

anxiety. One does not defend oneself against anxiety, any more (20) than there is a fear of aphanisis. Anxiety is at the source of defences, but one does not defend oneself against anxiety. Of course, if I tell you that I am going to consecrate a whole year to this subject of anxiety, this means that I am not claiming today to have dealt with every aspect of it, that it does not pose a problem. If anxiety - it is always at this level that my little apologue has defined for you in an almost caricatural way that anxiety is situated - if anxiety can become a sign, it is of course because transformed into a sign, it is perhaps not quite the same thing as it was where I tried to pose it for you at first at its essential point.

There is also a simulacrum of anxiety. At this level, of course, one can be tempted to minimise its import, in so far as it is really tangible that if the subject sends himself signs of anxiety it is obviously in order that things should be more cheerful. But it is all the same not from there that we can begin in order to define the function of anxiety; and then finally to say, as I have simply claimed to do today, massive things, let us open ourselves to this thought that if Freud told us that anxiety is a signal which happens at the level of the ego, it is all the same necessary to know that it is a signal for whom? Not for the ego, because it is at the level of the ego that it is produced. And I greatly regretted also, that at our last meeting no one dreamt of making this simple remark.

Seminar 17: Wednesday 11 April 1962

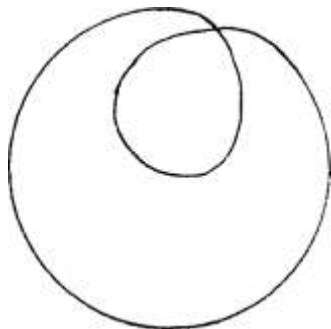

I had proposed that I would continue today about the phallus. Well I shall not be speaking to you about it or indeed I will only speak to you about it in the shape of this inverted eight which is not all that reassuring.

It is not a new signifier that is involved. You are going to see that it is still the same as the one that I have been speaking about in short from the beginning of this year; only the reason why I bring it forward as being essential, is to bring about a renewal with the topological base that is involved: namely what is meant by the introduction this year of the torus.

It is not so much of course that what I said about anxiety was all that well understood. Someone who is very nice and who reads - because it is someone from a milieu where people work, I must admit that I am choosing this example because it is rather encouraging - remarked to me in a very timely way that what I said about anxiety as desire of the Other overlapped with what is found in Kierkegaard. At a first reading - because it is quite true - you can well imagine that I remembered that Kierkegaard, in order to speak about anxiety, evoked the young girl at the moment when for the first time she realises that she is desired. Only if Kierkegaard said it, the difference with what I am saying is, as I might say to use a Kierkegaardian term, that I am (2) repeating it. If there is someone who has pointed out that it is never without reason that one says "I say and I repeat", it is precisely Kierkegaard. If one feels the need to underline that one is repeating it after having said it, it is because probably it is not at all the same thing to repeat it as to say it; it is absolutely certain that, if what I said the last time has a meaning, it is precisely because the case raised by Kierkegaard is something quite particular and as such obscures rather than clarifies the true meaning of the formula that anxiety is the desire of the Other - with a big 0.

It can happen that this other is incarnated for the young girl at a moment of her existence in some ne'er-do-well. This has nothing to do with the question that I raised the last time and with the introduction of the desire of the other as such in order to say that it is anxiety, more exactly that anxiety is the sensation of this desire.

Today I am going to come back therefore to my path for this year and that all the more rigorously because I had to make a digression the last time. And that is why, more rigorously than ever, we are going to do topology, and it is necessary to do it because you cannot but do it at every instant, I mean, whether you are logicians or not, whether you know the meaning of the word topology or not. You make use for example of the conjunction or. Now, it is rather remarkable but undoubtedly true that the usage of this conjunction was not properly articulated, properly specified, properly highlighted in the field of technical logic, of the logic of logicians until recent times, much too recent for its effects in short to have really reached you; and that is why it is enough to read the smallest current analytic text for example to see that at every instant thinking stumbles once it is a question, not only of the term identification, but even of the simple practice of identifying anything whatsoever in the field of our experience.

It is necessary to begin again from schemas unshaken in spite of everything, let us admit, in your thinking, unshaken for two reasons: first of all because they emerge from what I would call a certain peculiar incapacity properly speaking for intuitive thinking or more simply for intuition, which means at the very foundations an experience marked by the organisation of what is called the sense of vision. You will very easily grasp this intuitive impotence, if I have the good fortune that after this little conversation you set yourself to pose simple problems of representation about what I am going to show you can happen at (3) the surface of a torus. You will see the difficulty you will have not to become confused. Nevertheless a torus is quite simple: a ring. You will become confused, but then I become confused like you: I needed practice in order to find my bearings a little in it and even to grasp what that was suggesting and what that allowed to ground practically.

The other term is linked to what is called education, namely that everything is done to encourage this sort of intuitive impotence, to establish it, to give it an absolute character, that of course with the best of intentions. This is what happened for example when in 1741 Mr Euler, a very great name in the history of mathematics, introduced his famous circles which, whether you know it or not, did a lot in short to encourage the teaching of classical logic in a certain direction which far from opening it out could only tend unfortunately to render more evident the idea that simple schoolboys might have of it.

This happened because Euler had got it into his head, God knows why, to teach a princess, the princess of Anhalt Dessau. Throughout a whole period people were very preoccupied with

princesses, people are still preoccupied with them and that is unfortunate. You know that Descartes had his own one, the famous Christina. This is a historical tale of a different kind, he died of it. It is not altogether subjective, there is a kind of very particular stench which emerges from everything that surrounds the entity princess or Prinzessin. Throughout a period of about three centuries, we have something which is dominated by letters addressed to princesses, the memoirs of princesses, and this holds a certain place in the culture. It is a kind of substitute for this flaw [or dame] whose function, so difficult to understand, so difficult to approach, I tried to explain to you in the structure of courtly sublimation whose real import I am not at all sure after all of having made you really understand. I was really only able to give you kinds of projections of it in the way that one tries to depict four dimensional figures that cannot be had in another space.

I learned with pleasure that something about it reached ears which are close to me, and that people are beginning to interest themselves, not here but elsewhere, in what courtly love might be. It is already a result.

Let us leave the princess and the troubles that she gave Euler. He wrote 254 letters to her, not simply to make her understand Eulerian circles. Published in 1775 in London, they constitute a (4) sort of corpus of the scientific thinking at that date. The only thing that survived from it effectively are these little circles, these Eulerian circles which are circles like any other circles it is simply a matter of seeing the use that he made of them. It was to explain the rules of the syllogism and in the final analysis exclusion, inclusion and then what can be called the intersection of two what? Of two fields applicable to what? Well, my heavens, applicable to many things, applicable for example to the field where a certain proposition is true, applicable to the field where a certain relationship exists, applicable quite simply to the field where an object exists.

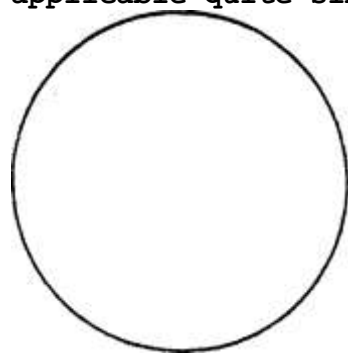

You see that the usage of the Eulerian circle, if you are used to the multiplicity of logics as they were elaborated in an immense effort, the greater part of which belongs to propositional logic and the logic of classes, was distinguished in the most useful fashion. I cannot even dream of entering of course into the details

that would be required to make the distinction between these elaborations. What I simply want to have recognised here, is that you surely remember one or other moment of your existence where there has come to you, under this form of a support, some logical proof or other, some object as a logical object, whether it involved a proposition, a class relationship, or even simply an object of existence.

Let us take an example at the level of the logic of classes

and let us represent this example by a small circle inside a big one, mammals with respect to the class of vertebrates; this works quite easily and all the more simply because the logic of classes is certainly what at the beginning opened up in the easiest way the paths to this formal elaboration and you should consult here something already

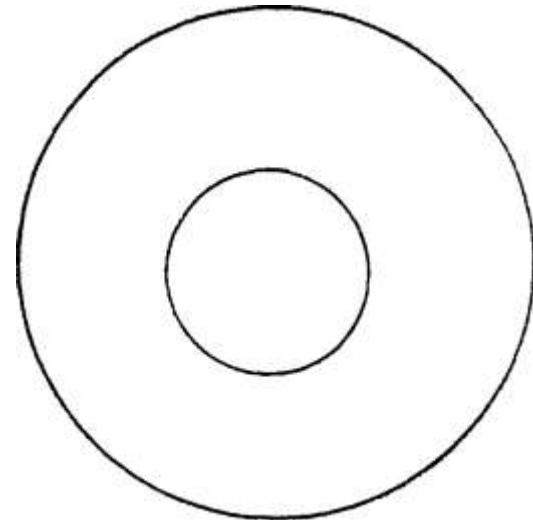

incarnated in a signifying elaboration, quite simply that of zoological classification which really gives it its model. But the universe of discourse, as it is quite correctly expressed, is not a zoological universe; and, by wanting to extend the properties of the universe of zoological classification to the whole universe of discourse, one easily slips into a certain number of traps which help you to avoid mistakes and allow there (5) to be heard rather quickly the alarm signal of an significant impasse.

One of these drawbacks is for example an ill-considered use of negation. It is precisely in recent times that this use was opened up as possible, namely just at the time when the remark was made that this exterior Eulerian circle of inclusion ought to play an essential role in the use

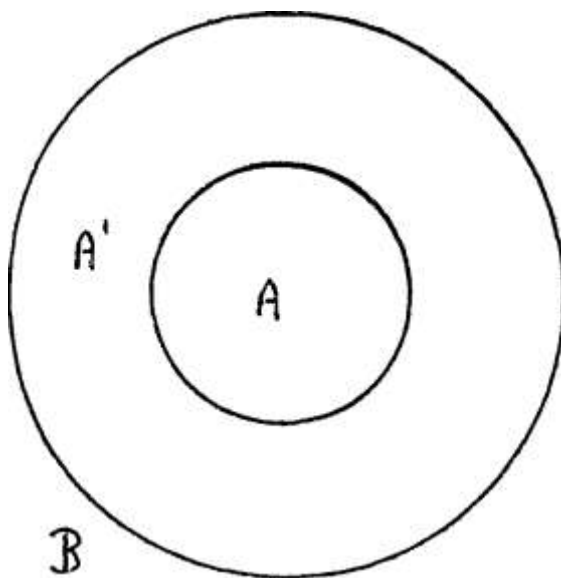

of negation, namely that it is absolutely the same thing to speak without any precision for example of that which is not-man or of that which is not-man within the animal world. In other words that in order that negation should have a more or less assured, usable meaning in logic, it is necessary to know in relation to what set something is denied. In other words if A^1 is not A, it is necessary to know within what it is not A, namely here in B.

$$A' = A$$

If you open Aristotle on this occasion, you will see negation dragged into all sorts of difficulties. It nevertheless remains incontestable that these remarks were not at all expected nor was the slightest use made of this formal support - I mean that it is not normal to make use of it in order to make use of negation - namely that the subject in his discourse frequently makes use of

elsewhere than where It found its established position that we have to define the status of negation. It is a reminder, a reminder designed to clarify for you retrospectively the importance of what from the beginning of my discourse of this year I have been suggesting to you about the primordial originality of the function of negation compared to this distinction.

You see then that it was not Euler who used these Eulerian (6) circles for this purpose; it was necessary in the meantime for there to be introduced the work of Boole, then that of De Morgan in order that this should be fully articulated.

If I come back to these Eulerian circles then, it is not because he himself made good use of them, but because it was with his material, with the use of these circles that there could be made the progress which followed of which I will give you at the same time an example which is not the least important nor the least notorious, in any case particularly gripping and immediate to see.

Between Euler and De Morgan the use of these circles allowed a symbolisation which is useful also in that it appears to you moreover implicitly fundamental, which reposes on the position of these circles which are structured as follows: this is what we will call two circles which intersect, which are especially important for their intuitive appearance which will appear incontestable to everyone if I point out to you that it is around these circles that there can be first of all be articulated two relationships which it would be well to accentuate strongly, which are first of all that of union: involving anything whatsoever that I enumerated earlier, \cup their union, it is the fact that after the operation of union, what is united are these two fields.
is precisely what introduced this

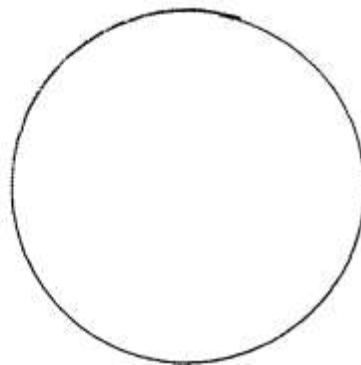
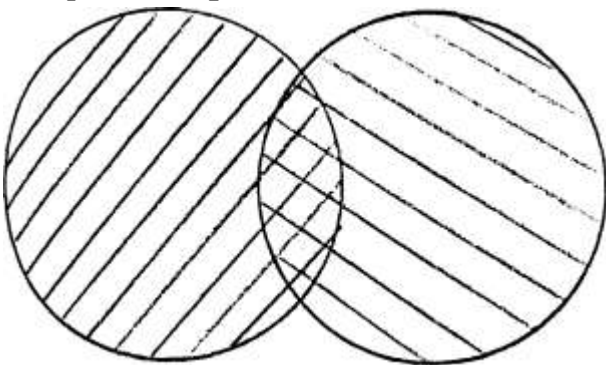

The operation described as union which is ordinarily symbolised as follows: \cup - it symbol - is, as you see, something which is not altogether like addition, the advantage of these circles is to make you sense that. It is not the

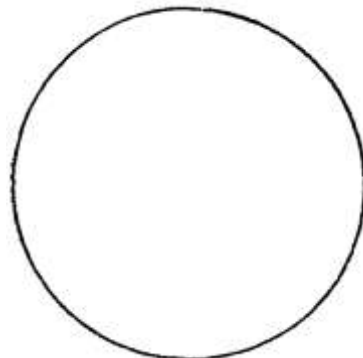

same thing for example to add two separate circles or to unite them in this position.

(7) There is another relationship illustrated by these overlapping circles: it is that of intersection, symbolised by this sign \cap whose signification is completely different. The field of intersection is included in the field of union.

union	\cup	+
intersection	\cap	X

In what is called Boolean algebra, it is shown that, up to a certain point at least, this operation of union is analogous enough to addition for it to be able to be symbolised by the sign of addition (+). It is also shown that intersection is structurally analogous enough to multiplication for it to be symbolised by the sign of multiplication (X).

I assure you that I am giving here an ultra-rapid extract designed to lead you where I have to lead you and I apologise of course to those for whom these things present themselves in all their complexity for the elisions that all of this involves. Because we must go further and on the precise point that I have to introduce, what interests us, is something which up to De Morgan - and one can only be astonished at such an omission - had not been properly speaking highlighted as precisely one of these functions which flow from, which ought to flow from an altogether rigorous usage of logic, it is precisely this field constituted by the extraction, in the relationship between these two circles of the zone of intersection.

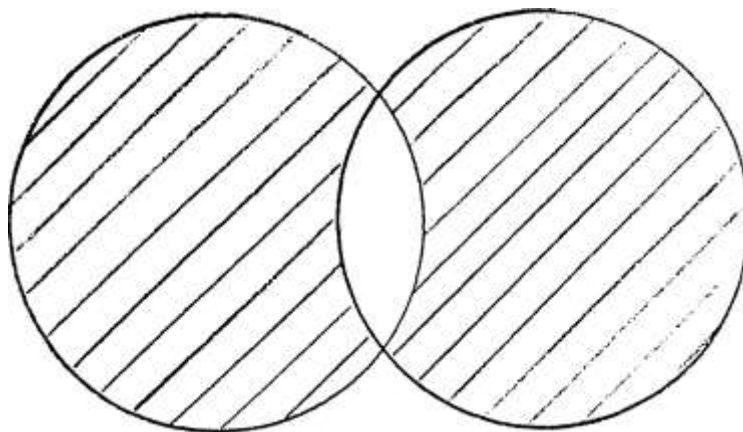

And to consider what the product is, when two circles cut, at the level of a field described in this way, namely the union minus the intersection. This is what is called the symmetric difference.

This symmetric difference is what is going to retain our (8) attention, what for us - you will see why - is of the greatest interest. The term symmetric difference is here an appellation that I would simply ask you to take for its additional usage. This was what it was called. Do not try

therefore to give a grammatically analysable meaning to this so-called symmetry. The symmetric difference, this is what that means, that means: these fields, in the two Eulerian circles, in so far as they define as such an exclusive "or". With respect to two different fields, the symmetric difference marks the field as it is constructed if you give to the "or", not the alternative sense, but one which implies the possibility of a local identity between the two terms; and the usual usage of the term "or" means that in fact the term "or" applies here very well to the field of union. If a thing is A or B, this is how the field of its extension can be drawn, namely in the first form that these two

fields are discovered. If on the contrary A or B is exclusive this is how we can symbolise it, namely that the field of intersection is excluded.

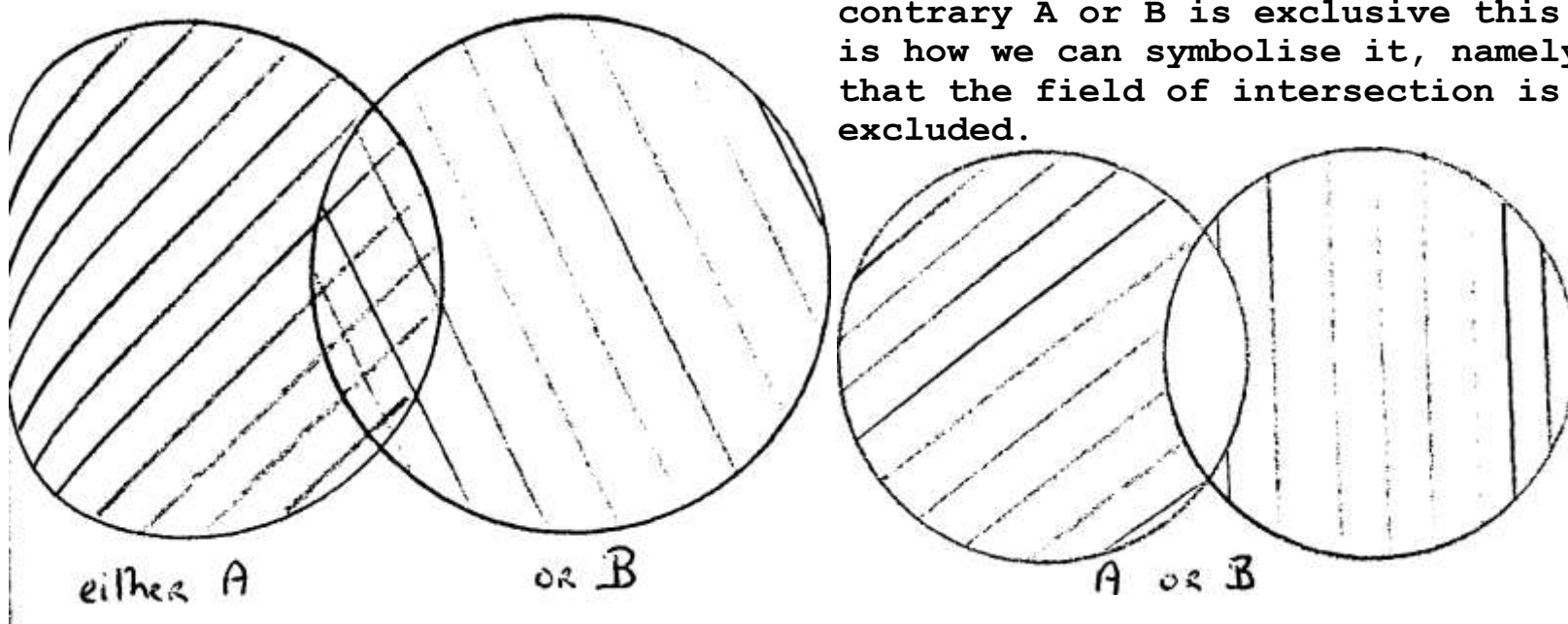

This should lead us back to a reflection about what is intuitively supposed by the usage of a circle as a basis, as a support for what is formalised in function of a limit. This is very sufficiently defined in the fact that on a commonly used plane, which does not mean a natural plane, a plane that can be fabricated, a plane which has completely entered into our universe of implements, namely a sheet of paper, we live much more in the company of sheets of paper than in the company of tori. There must be reasons for that but after all reasons which are not evident. Why after all does man not fabricate more tori? Moreover for centuries, what we nowadays have in the form of sheets were rolls which must have been more familiar with the notion of volume in epochs other than our own. Finally there is certainly a reason why this plane surface is something which (9) suffices for us and more exactly that we satisfy ourselves with it. These reasons must be somewhere. And - I indicated it earlier - one cannot give too much importance to the fact that, contrary to all the efforts of physicists and philosophers to persuade us of the contrary, the field of vision whatever is said about it is essentially two-dimensional:

is made of it in the Eulerian illustration of logic. I pose the following question to you: what happens if Euler, instead of drawing this circle, draws my inverted eight the one that today I have to talk to you about?

In appearance it is only a particular case of the circle with the inside field that it defines and the possibility of having another circle within. Simply the inside circle touches - here

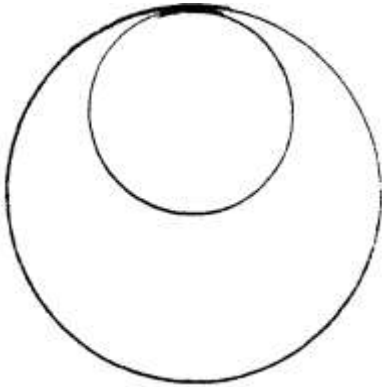

is what at first sight some people may say to me - the inside circle touches on the limit constituted by the outside circle. Only it is all the same not quite that, in this sense that it is quite clear, in the way I draw it, that the line here of the outside circle continues into the line of the inside circle and finds itself here.

And so in order simply immediately to mark the

interest, the import of this very simple shape, I will suggest to you that the remarks that I introduced at a certain point of my seminar when I introduced the function of the signifier consisted in the following: reminding you of the paradox or the supposed one introduced by the classification of sets - you remember - which do not include themselves.

I remind you of the difficulty they introduce: should one or should one not include these sets which do not include themselves (10) in the set of sets which do not include themselves? You see the difficulty here. If yes, then they include themselves in this set of sets which do not include themselves. If not, we find ourselves confronted with an analogous impasse.

E^E Sets which include themselves.

$E^{\neg E}$ Sets which do not include themselves.

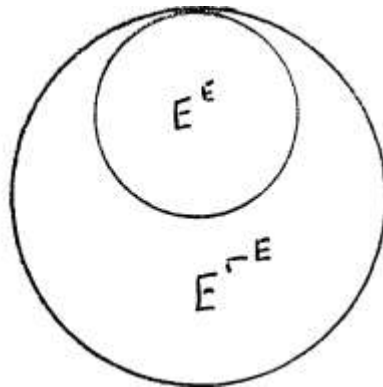

This is easily resolved on this simple condition that one grasps at least the following - it is the solution that moreover the formalists, the logicians have given - that one cannot speak, let us say in the same way, about sets which include themselves and sets which do not include themselves. In other words that one excludes them as such from the simple definition of sets, that

one poses when all is said and done that the sets which include themselves cannot be posed as sets. I mean that far from this inside zone of objects as important in the construction of modern logic as sets, far from an inside zone defined by this image of the inverted eight by the overlapping or the redoubling in this overlapping of a class, of a relation, of some proposition or other by itself, by being raised to a second power, far from this leaving as a well-known case the class, the proposition, the relationship in a general fashion, the category inside itself in a fashion that is in a way more weighty more accentuated, this has the effect of reducing it to homogeneity with what is outside.

How is this conceivable? For indeed one must all the same clearly say that, if this is the way that the question is presented, namely among all the sets, there is no a priori reason not to make of a set which includes itself a set like the others. You define as a set for example all the works that refer to the (11) humanities, namely to the arts, to the sciences, to ethnography. You make a list of them; the works produced on the question of what one should class as humanities will form part of the same catalogue, namely that what I have even defined just now in articulating the title: works about the humanities, forms part of what is to be catalogued.

How can we conceive that something which is thus posed as redoubling itself in the dignity of a certain category can find itself practically leading us to an antinomy, to a logical impasse such that we are on the contrary constrained to reject it? Here is something which is not as unimportant as you might think because one has practically seen the best logicians see in it a sort of failure, a stumbling block, a vacillating point of the whole formalist edifice, and not without reason. Here is something which nevertheless puts to intuition a sort of major objection, inscribed, tangible, visible of itself in the very form of these two circles which are presented, in the Eulerian perspective, as included one in the other.

It is precisely on this point that we are going to see that the use of the intuition of the representation of the torus is quite usable. And given that you clearly sense, I imagine, what is involved, namely a certain relationship of the signifier to itself, as I told you, it is in the measure that the definition of a set has got closer and closer to a purely signifying articulation that it leads us to this impasse, it is the whole question of the fact that it is a matter for us of putting in the foreground that a signifier cannot signify itself. In fact it is something excessively stupid and simple, this very essential point that the signifier in so far as it can be used to signify itself has to be posed as different to itself. This is what it is a matter of symbolising in the first place because it is also this that we are going to rediscover, up to a certain point of extension which it is a matter of determining, in the whole subjective structure up to and including desire.

When one of my obsessionals, quite recently again after having

developed all the subtlety of the science of his exercises with respect to feminine objects to whom, as is common among other obsessives, he remains attached, as I might say, by what one can call a constant infidelity: at once the impossibility of leaving any of these objects and the extreme difficulty of (12) maintaining them all together, and that he adds that it is quite clear that in this relationship, in this so complicated relationship which requires this high degree of technical subtlety, as I might say, in the maintaining of relationships which in principle must remain outside one another, impermeable as one might say to one another and nevertheless linked, that, if all of this, he tells me, has no other purpose than to leave him intact for a satisfaction which he himself here comes to grief on, it must therefore be found elsewhere, not just simply in a future that is always put off, but manifestly in another space since as regards this intactness and its purpose he is incapable when all is said and done of saying at what this could end up in terms of satisfaction.

We have all the same here in a tangible way, something which can pose for us the question of the structure of desire in the most day-to-day fashion.

Let us come back to our torus and let us inscribe on it our Eulerian circles. This is going to necessitate - I apologise for it - a tiny little twist which is not, even though it might appear so to someone who comes into my seminar today for the first time, a geometrical twist - it will be that perhaps right at the end but very incidentally - which is properly speaking topological. There is no need for this torus to be a regular torus nor a torus on which we could make measurements. It is a surface constituted according to certain fundamental relationships that I am going to be led to remind you of, but because I do not want to appear to go too far from what is the field of our interest I am going to limit myself to things that I have already initiated and which are very simple.

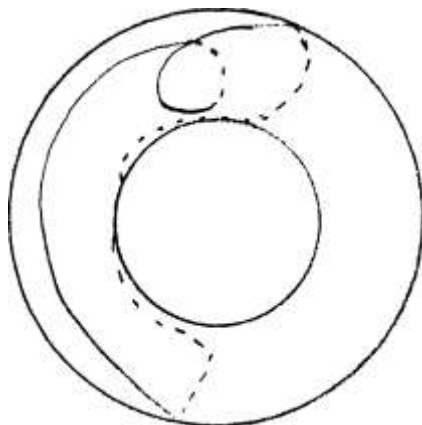

As I pointed out to you: on a surface like this, we can describe this type of circle which is the one that I have already connoted (13) for you as reducible, one which if it is represented by a

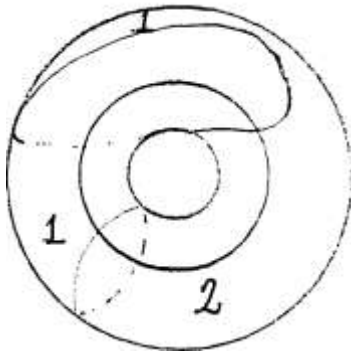

little string which passes at the end through a buckle, I can by pulling on the string reduce to a point, in other words to zero. I pointed out to you that there are two other kinds of circle or loop whatever size they may be because for example this one here could just as well have that shape there:
(1)

That means a circle which goes through the hole whatever may be its more or less tight more or less loose shape. This is what defines it: it goes through the hole it passes to the other side of the hole. It is represented here in dots while the 2 is represented in full. This is what that symbolises: this circle is not reducible, which means that if you suppose it to be realised by a string still passing through this little arch which would allow us to tighten it we cannot reduce it to something like a point; whatever its circumference may be, there will always remain at the centre, the circumference of what one could call here the thickness of the torus. If from the point of view which interested us earlier, namely the definition of an inside and an outside, this irreducible circle shows from one side a particular resistance, something which with respect to other circles confers on it an eminent dignity, on this other point here suddenly it is going to appear singularly deprived of the properties of the preceding one; because if you materialise this circle that I am talking to you about for example by a cut with a pair of scissors, what will you obtain? Absolutely not, as in the other case, a little piece which disappears and then the remainder of the torus. The torus will remain entirely intact in the form of a pipe or of a sleeve if you wish.

If you take on the other hand another type of circle, the one that I already spoke to you about, the one which does not go through the hole, but goes around it, this one finds itself in the same situation as the preceding one as regards irreducibility. It also finds itself in the same situation as the preceding one as regards the fact that it is not sufficient to define an inside or an outside. In other words that if you follow this circle and if you open the torus with the help of a pair of scissors, you will finally get what? Well, the same thing as in the preceding case: this has the shape of a torus but it is a shape which presents only an intuitive difference, which is altogether essentially the same from the point of view of (14) structure. You always have after this operation, as in the first case, a sleeve, simply it is a very short and a very wide sleeve, you have a belt if you wish but there is no essential difference between a belt and a sleeve from the topological point of view, again you can call it a strip if you wish.

Here we are then in the presence of two types of circle which from this point of view moreover are the same, which do not define an inside and an outside. I would point out to you incidentally that, if you cut the torus successively following

one and the other, you will still not manage for all that to make what it is a matter of making and what you nevertheless obtain immediately with the other type of circle 1 (p 10), the first one that I drew for you, namely two pieces. On the contrary the torus not only remains well and truly entire, but it was, the first time that I spoke to you about it, a flattening out that resulted from it which allows you to symbolise the torus eventually in a particularly convenient fashion as a rectangle which you can, by pulling a little, spread out like a skin pinned down at the four corners, to define the properties of correspondence of these edges one to the other, of correspondence also of its vertices, the four vertices which unite at a point and to have in this way, in a fashion much more accessible to your ordinary faculties of intuition, the means of studying what happens geometrically on the torus, namely that there will be one of these types of circle which will be represented by a line like

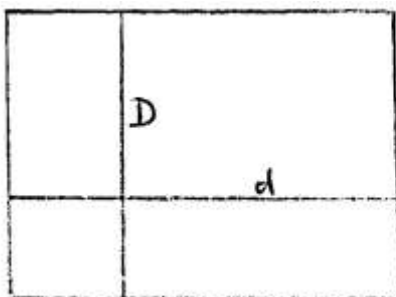

this one another type of circle by lines like this representing two points posed, defined in a preliminary fashion as being equivalent on what are called the edges of the spread-out flattened surface, as I might say, even though of course it is not a real flattening out, a flattening-out as such being (15) impossible because we are not dealing with a surface which is metrically identifiable to a plane surface, I repeat purely metrically, not topologically.

Where does all this lead us?

The fact that two sections of this kind are possible, with moreover the necessity of the one or the other being regrouped without fragmenting the surface in any way, leaving it whole and entire, leaving it in one piece, as I might say, this is enough to define a certain type of surface. Not all surfaces are of this type; if you carry out in particular a section like that on a sphere, you will always only have two pieces whatever the circle may be.

This in order to lead us to what?

Let us make no longer a single section but two sections on the single base of the torus. What do we see appearing? We see appearing something which undoubtedly is going to astonish us immediately, namely that if the two circles are regrouped, what is called the field of the symmetric difference well and truly exists. Can we say, for all that, that the field of intersection exists? I think that this figure, as it is constructed, is sufficiently accessible to your intuition for you to clearly

understand immediately and right away that there is no question of it.

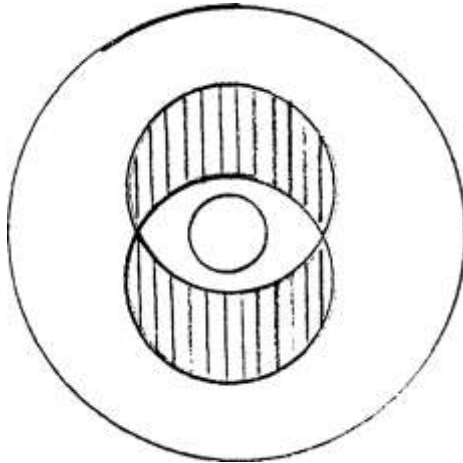

Namely that this something which might be the intersection, but which is not one and which, I am saying, for the eye because of course there is no question for a single instant of this intersection existing, but which for the eye is, as I have presented it to you in this way on this figure as it is drawn, would be found perhaps somewhere here (see the schema) of this field perfectly continuous in a single block, in a single piece with this field here which could analogically, in the crudest fashion for an intuition precisely accustomed to base itself on things which happen uniquely on the plane, to correspond to this external field where we could define, with respect to two Eulerian circles cutting one another, the field of their negation, namely if here we have the circle A and here the circle B, here we have A' as a negation of A and we have here B' as a negation of B, and there is something to be formulated concerning their intersection at these eventual external fields.

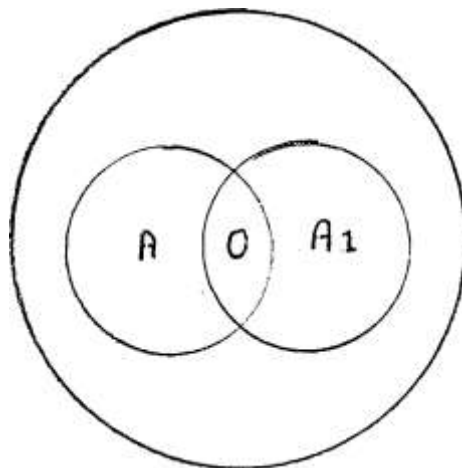

Here we see illustrated then in the simplest fashion by the structure of the torus the fact that something is possible, something which can be articulated as follows: two fields cutting one another being as such able to define their difference qua symmetric difference, but which are nonetheless two fields about which one can say that they cannot unite and that neither can they overlap one another, in other words that they cannot serve either as a function of "either..., or...", of union, nor as a function of multiplication (intersection) by itself. They can

literally not be raised to a higher power, they cannot be reflected one by the other and one in the other; they have no intersection, their intersection is exclusion from themselves. The field where one would expect intersection is the field where you leave behind what concerns them, where you are in the non-field. This is all the more interesting in that for the representation of these two circles we can substitute our inverted eight of a little while ago.

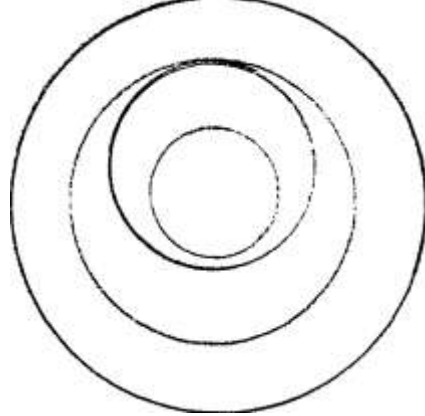

(17) We find ourselves then before a shape which for us is still more suggestive. For let us try to remind ourselves of what I thought of immediately in comparing these circles which make the circuit of the hole of the torus to something which, I told you, is related to the metonymical object, to the object of desire as such. What does this inverted eight, this circle which continues itself inside itself, what is it, if not a circle which at the limit redoubles itself and grasps itself again, which allows there to be symbolised - because it is a question of intuitive evidence and the Eulerian circles appear particularly appropriate for a certain symbolisation of the limit - which allows this limit to be symbolised in so far as it takes itself up again, as it identifies itself to itself. Reduce more and more the distance which separates the first loop, let us say, from the second and you have the circle in so far as it grasps itself. Are there objects which for us have this nature, namely, that they uniquely subsist in this grasp of their self-difference? Because it is either one thing or the other: either they grasp it, or they do not grasp it... But there is one thing in any case that everything which happens at this level of the grasp implies and requires, it is that this something excludes any reflection of this object onto itself. I mean that suppose that it is small o that is involved, since I already indicated to you that this was what these circles were going to be used for by us, that means that o^2 , the field thus defined, is the same field as what is there, namely not $\frac{o}{o^2}$ or $-\frac{o}{o^2}$.

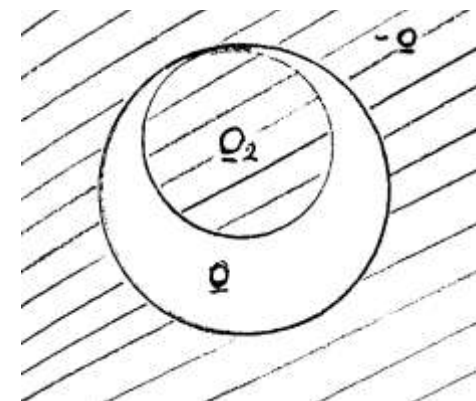

Suppose for an instant, I did not say that it has been proved, I am telling you that I am providing you today with a model, an intuitive support for something which is precisely what we need concerning the constitution of desire. Perhaps it will appear to you

more accessible, more immediately within your reach to make of it the symbol of the self-difference of desire to itself and the fact that it is precisely by its redoubling onto itself that you (18) are going to see what it encompasses slipping away and escaping towards what surrounds it. You will say: stop, hold on here, because it is not really desire that I intend to symbolise by the double loop of the inverted eight but something which applies much better to the conjunction of small o, of the object of desire as such with itself. In order that desire should be effectively, intelligently supported in this intuitive reference to the surface of the torus, it would be well of course to bring into it the dimension of demand. I told you on the other hand that the circles encompassing the thickness of the torus as such could very intelligibly serve to represent this dimension of demand and that something moreover which is in part contingent, I mean linked to a completely exterior, visual perception, itself too marked by common intuition not to be refutable, as you will see, but after all because of the way you are forced to represent the torus for yourself, namely something like this ring, you quickly see how easily what happens in the succession of these circles capable of continuing in a way in a helix and by to a repetition which is like that of a thread around a spool, how easily the demand in its repetition, its identity and its necessary distinction, its unfolding and its return onto itself, is something which easily finds something to support it in the structure of the torus.

It is not this that I intend today to repeat once again. Moreover, if I were only to repeat it here, it would be quite insufficient; it is on the contrary something to which I would like to draw your attention, namely this privileged circle which is constituted by the fact that it is not only a circle which makes a circuit around the central hole, but it is also a circle which goes through it. In other words that it is constituted by a topological property which merges, which adds together the loop (boucle) constituted around the thickness of the torus to the one which would be made by a circuit made for example around the inside hole.

This sort of loop has an altogether privileged interest for us; because it is what is going to allow us to support, to depict, the relationships of demand and desire as structural.

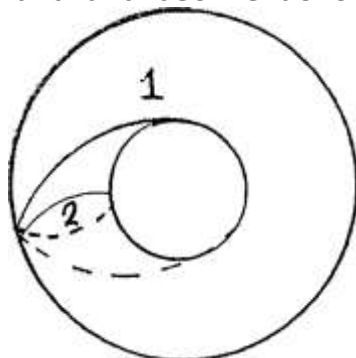

(19) Let us see in effect what emerges about such loops: observe that some can be so constituted, that another next to it is

completed, comes back on itself, without in any way cutting the first. As you see, given what I tried here to clearly articulate, to clearly draw, namely the fashion in which this passes to the other side of this object which we suppose to be a solid mass because that is the way you intuit so easily and which obviously is not, the line of circle 1 passes here, the other line 3 passes a little further on. There is no kind of intersection between these two circles.

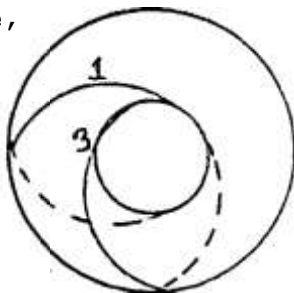

Here are two demands which while implying the central circle with what it symbolises - on this occasion, the object, and in what measure it is effectively integrated to demand, this is what our subsequent developments allow us to articulate - these two demands do not involve any kind of overlapping, any kind of intersection and even any kind of articulatable difference

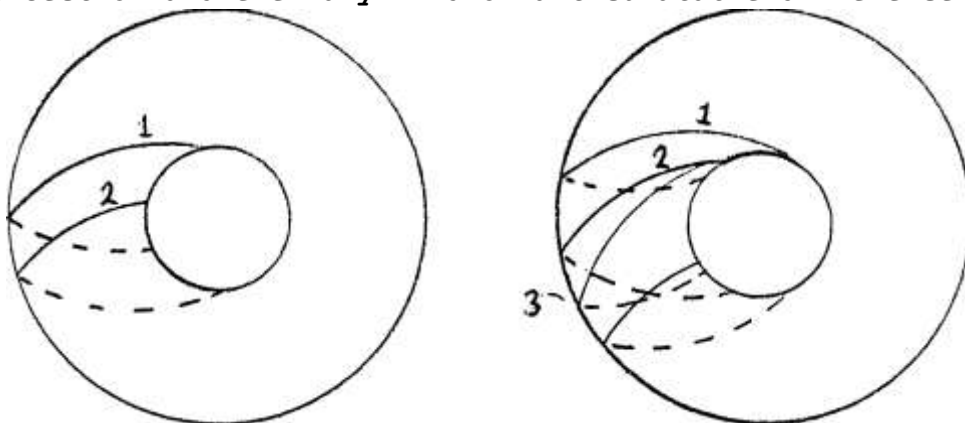

between them even though they have the same object included in their perimeter. On the contrary there is another phase of the circuit, the one which effectively passes to the other side of the torus, but far from connecting up with itself at the point from which it started begins here another curve in order to come back a second time to pass by here and come back to its point of departure.

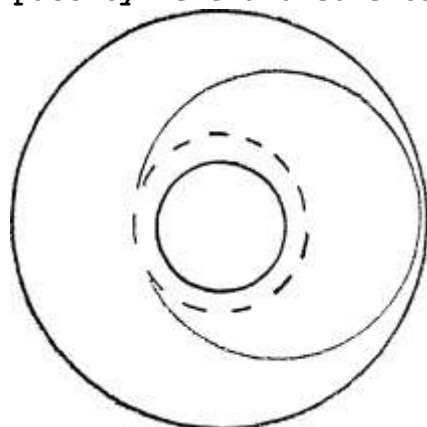

(20) I think that you have grasped what is involved; it is a matter of nothing less than something absolutely equivalent to the famous curve of the inverted eight which I spoke to you about earlier. Here the two loops represent the reiteration, the

reduplication of demand and so involve this field of difference to itself, of self-difference which is the one on which we put the accent earlier, namely that here we find the means of symbolising in a tangible fashion, at the level of demand itself, a condition for it to suggest, in all its ambiguity and in a fashion strictly analogous to the fashion in which it is suggested in the reduplication earlier of the object of desire itself, the central dimension constituted by the void of desire. I am bringing all of this to you only as a sort of proposal for exercises, for mental exercises, exercises with which you have familiarise yourself, if you subsequently want to be able to find in the torus the metaphorical value that I shall give it when I shall in every case, whether it is a matter of the obsessional, of the hysteric, of the pervert, even of the schizophrenic, have to articulate the relationship between desire and demand. That is why it is in other shapes, in the shape of the unfolded, flattened out torus of earlier on, that I am going to try to clearly mark for you what the different cases that I have evoked up to now correspond to, namely the two first circles for example which were the circles which made the circuit of the central hole and which cut one another by constituting properly speaking the same figure of symmetric difference as that of the Eulerian circles.

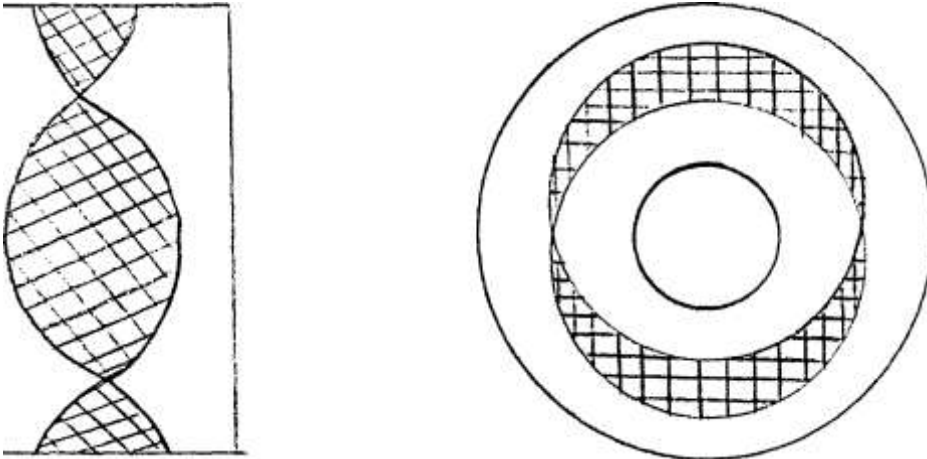

(21) Here is what that gives on the spread-out torus, certainly in this more satisfyingly illustrated fashion than the one you saw earlier because you can put your finger on the fact that there is no symmetry, let us say between the four fields, two by two, as they are defined by the cutting of the two circles.

You could have said to yourself earlier, and certainly in a fashion which would have been the sign of a lack of attention, that by drawing the things in this way, and by giving a privileged value to what I am calling here symmetric difference,

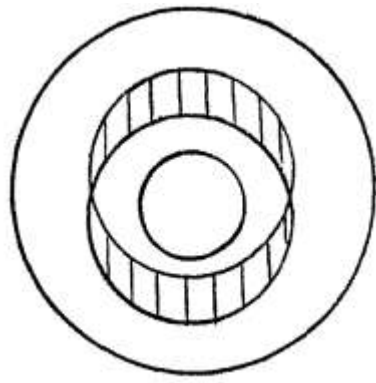

that all I am doing here is something rather arbitrary since the two other fields which I pointed out to you were merged, occupied perhaps with respect to these two here a symmetrical place. You see that it is nothing of the kind, namely that the fields defined by these two sectors, however you join them up - and you can do it - are in no way identifiable to the first field.

The other figure, namely that of the inverted eight presents itself as follows:

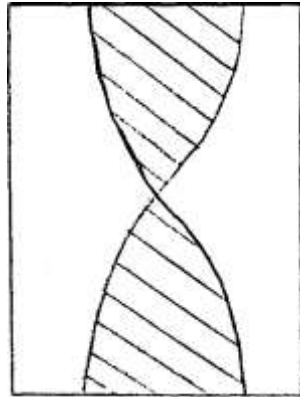

The non-symmetry of the two fields is still more obvious: the two circles which I subsequently drew successively on the periphery of the torus as defining two circles of demand in so far as they do not cut one another are now symbolised here. There is one (22) that we can identify purely - I am speaking about the two circles of demand as I have just defined them in so far as they included in addition the central hole - one can be very easily defined, be situated on the spread-out torus as an oblique line diagonally linking a vertex to the same point which it really is on the opposite edge; to the vertex opposite its position, AB.

loop that I drew would be as follows: with some point here, we have here a point C which as this point C¹ up at B': A'B'CB'.

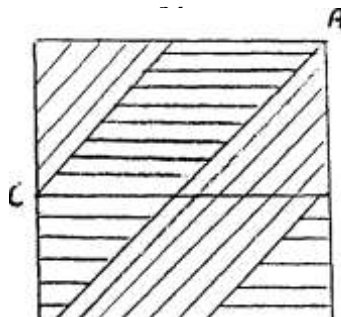

The second earlier symbolised beginning or other A', here B', is the same and ending

There is here no possibility of distinguishing⁵ between the field which is in A and A¹. It has no privileges with respect to this field. It is not the same if on the contrary it is the inside eight that we symbolise, because in^{hat} case it presents itself as follows:

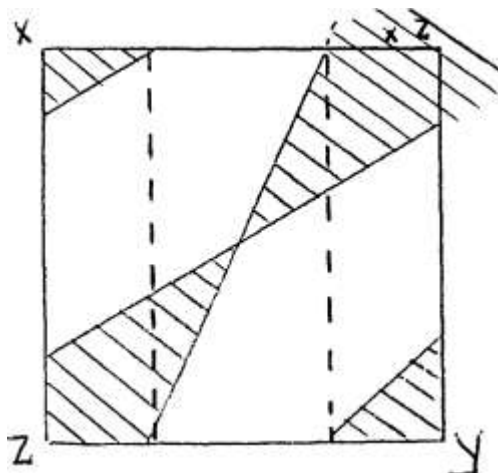

Here is one of these fields: it is defined by the shaded parts here. It is obviously not symmetrical with what remains of the other field, however you try to recompose it. It is quite obvious that you can try to recompose it in the following fashion, that this element there - let us say the x - coming here, this y coming there and this z coming here you would have the shape defined by the self-difference drawn by the inside eight.

This business, whose utilisation we will subsequently see, may appear to you a little bit fastidious, even superfluous as I try to articulate it for you. Nevertheless I would like to point out to you what it is used for. You see clearly: the whole accent that I put on the definition of these fields is designed to mark for you how these fields of symmetric difference and of what I (23) call self-difference can be used, how they can be used for a certain end and how they are sustained as existing with respect to another field that they exclude.

In other words if I go to so much trouble to establish their asymmetrical function it is because there is a reason. The reason is the following: the fact is that in the case of the torus, as it is structured purely and simply as surface, it is very difficult to symbolise in a valid fashion what I would call its asymmetry. In other words when you see it spread out namely in the shape of this rectangle which would involve, in order to reconstitute the torus, that you should imagine in the first place that I fold it and make a tube, and in the second place that I take one end of the tube and make a closed tube. It remains nonetheless that what I did in one direction I could have done in the other one.

Because it is a question of topology and not of metrical properties, the question of the greater length of one side with respect to the other has no significance. That it is not this which interests us, because it is the reciprocal function of these circles that it is a matter of utilising. Now precisely in this reciprocity they appear to be able to have strictly equivalent functions. Moreover this possibility is at the basis of what I had first allowed to emerge, to appear from the beginning for you in the utilisation of this function of the torus as a possibility of a tangible image in its connection, the fact is that in the case of certain subjects, certain neurotics for example, we see in a way in a tangible fashion the projection, if I can put it this way, of the very circles of desire in the whole measure that it is a matter for them, as I might say, of finding a way out of it in the demands required of the Other. And this is what I have symbolised by showing you this: it is that if you draw a torus you can simply imagine another one which encompasses as one might say the first one in this way; it is necessary to see clearly that each one of the circles around the hole can have by simple rotation their correspondence in circles which go through the hole of the other torus, that a torus in a way is always transformable in all its points into an opposite torus.

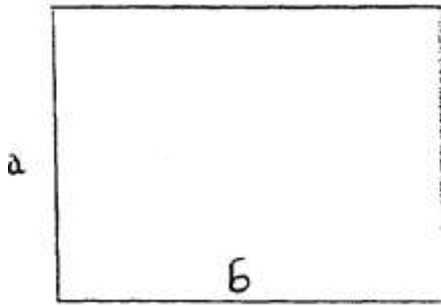

What it is a matter of seeing therefore is what gives its originality to one of these circular functions, that of full circles for example compared to what we have called at another moment empty circles. This difference very obviously exists, one could for example symbolise it, formalise it by indicating through a

(24) little sign on the surface of the torus spread out as a rectangle, if you wish, the priority according to which the folding is to be done, and if we called this side small a and this side small b , to note for example small a under small b , or inversely. This would be a notation that nobody in topology has ever dreamt of and which would have something quite artificial about it because it is hard to see why a torus should in any way be an object which might have a temporal dimension.

From that moment on, it is quite difficult to symbolise it otherwise, even though one can see clearly that there is here something irreducible and which gives properly speaking all its exemplary virtue to the toric object.

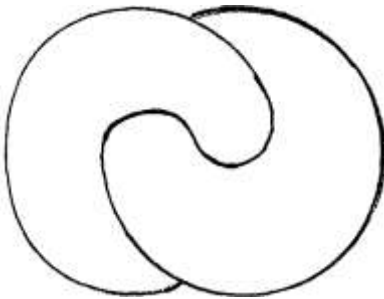

There would be another way to try to tackle it. It is quite clear that it is in so far as we only consider the torus as a surface taking its co-ordinates from its own structure alone that we are faced with this impasse, which has serious consequences for us because obviously if these circles which you see I tend to make use of to fix the demand in them in its relationships of course

with other circles which have a relationship with desire, if they are strictly reversible, is this something that we want to have for our model? Certainly not. It is on the contrary an essential privilege of the central hole that is involved; and as a consequence the topological status that we are seeking as utilisable in our model, is going to flee from us and escape us. It is precisely because it is going to flee and escape that it is going to reveal itself as fruitful for us.

Let us try another method to mark something that the mathematicians, the topologists do perfectly well without in the definition, the use, that they make of this structure of the torus in topology: they themselves, in the general theory of surfaces, have highlighted the function of the torus as an irreducible element in any reduction of surfaces to what one calls a normal form. When I say that it is an irreducible element, I mean that one cannot reduce the torus to something else. You can imagine surface shapes as complex as you wish but it is always necessary to take into account the function of the torus in all planification, if I can express myself in this way, in all triangulation in the theory of surfaces. The torus does (25) not suffice, other terms are necessary, specifically the sphere is necessary, there is necessary in it something that I was not even able to make an allusion to today, to introduce the

possibility of what is called the cross-cap and the possibility of holes.

When you have the sphere, the torus, the cross-cap and the hole, you can represent any of what are called the compact surfaces, in other words a surface which is decomposable in pieces. There are other surfaces which are not decomposable, but we leave them aside.

Let us come now to our torus and to the possibility of its orientation. Are we going to be able to do it with respect to the ideal sphere onto which it is hooked? We are always able to introduce this sphere, namely if you blow enough, any torus whatsoever can come to be represented as a simple handle at the surface of a sphere which is a sufficiently inflated part of itself. Are we going to be able through the mediation of the sphere, as I might say, to replunge the torus into what - you sense it clearly - we are seeking for the moment, namely this third term which allows us to introduce the asymmetry we need between the two types of circles?

This asymmetry which is nevertheless so obvious, so intuitively tangible, so irreducible even and which is nevertheless of such a kind that it manifests itself in this connection as being this something which we always observe in every mathematical development: the necessity, for it to get started, of forgetting something at the beginning, this you will find in every kind of formal progress, this something forgotten and which literally escapes us, flees us in the formalism - are we going to be able to grasp it for example in the reference to something which is called the tube of the sphere?

In effect, look carefully at what happens and are we told that in reduction every formalisable surface can give us the normal shape? We are told that this will always come back to a sphere, with what? With tori inserted on it and which we can validly symbolise as follows. I will spare you the theory, experience proves that it is strictly accurate. That in addition we will have what are called cross-caps. These cross-caps, I am not going to speak to you about them today, I will have to speak to you about them because they will be of the greatest use to us. Let us be satisfied with considering the torus.

(26) We might get the idea that a handle like this one, which is not outside the sphere, but inside with a hole in order get into

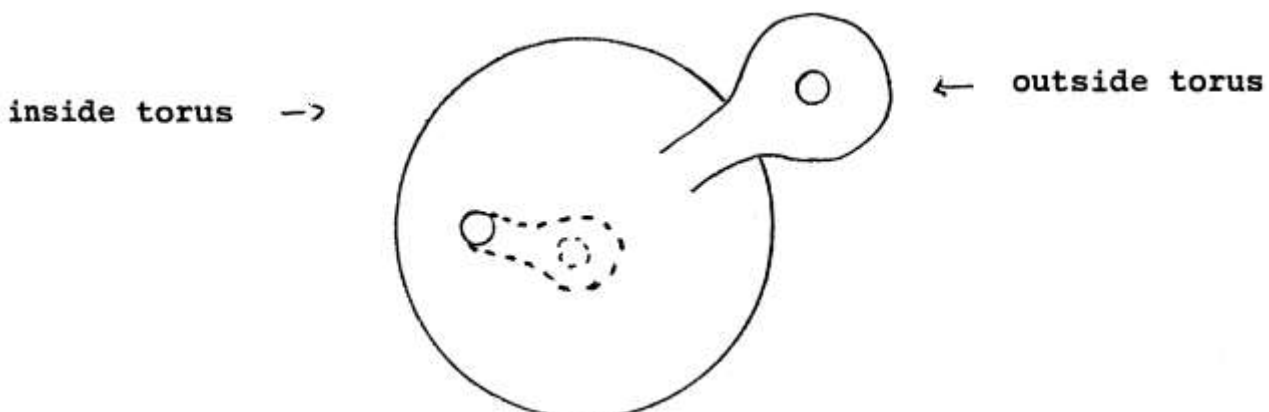

it is something irreducible, uneliminateable and that it would be necessary in a way to distinguish outside tori from inside tori.

What is the interest of this for us? Very precisely in connection with a mental form which is necessary for our whole intuition of our object. In effect in the Platonic, Aristotelian, Eulerian perspective of an Umwelt and of a Innenwelt, of a dominance placed from the beginning on the division between inside and outside, will we not place everything that we experience, and specifically in analysis, within the dimension of what I called the other day the underground, namely the corridor which goes down into the depths, in other words, to the maximum degree, I mean in its most developed form according to this shape.

It is extremely exemplary to make you sense in this connection the absolute non-independence of this shape; because I repeat to you in so far as one arrives at reduced shapes which are the shapes inscribed, vaguely sketched on the blackboard with the aim of giving a support to what I am saying, it is absolutely impossible to sustain as different for even an instant, the eventual originality of the inside handle compared to the outside (27) handle, to employ the technical terms. It is enough for you, I think, to have a little imagination to see that if it is a question here of something that we materialise in rubber it is enough to introduce your finger here (see the schema) and to hook

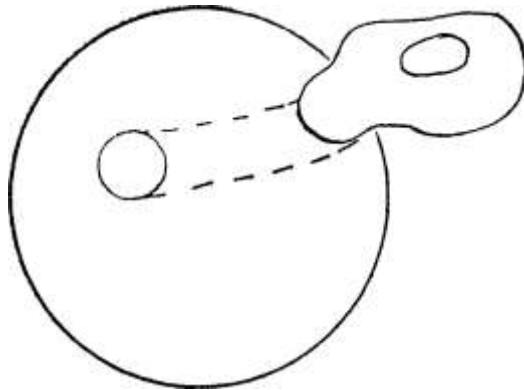

onto the central ring of this handle as it is here constituted from the inside in order to extract it to the outside exactly according to a shape which would be the following, namely a torus that is exactly the same, without any kind of tearing, nor even properly speaking inversion. There is no inversion: what was inside, namely the journeying in this way from the inside of the corridor, becomes the outside because it always was. If that surprises you, I can illustrate it again in a more simple fashion which is exactly the same because there is no difference between this and what I am going to show you now and what I showed you from the first day, hoping to make you sense what was involved. Imagine that it is in the middle of its journey, which is exactly the same thing from the topological point of view, that the torus is caught in the sphere; you have here a little corridor which travels from one hole to another hole. Here I think that it is sufficiently tangible that it is not difficult, simply by making bulge a little what you can grasp through the corridor with your

finger, to make appear a figure which would be more or less the following: something which is here a handle and whose two holes communicating with the inside are here in dots.

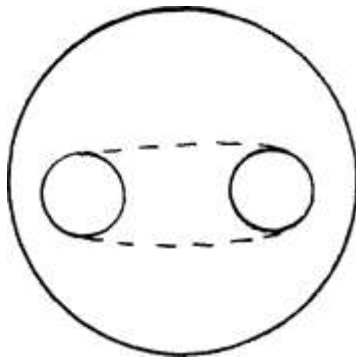

We arrive then at a further failure, I mean at the impossibility, by a reference to the third dimension here represented by the sphere, of symbolizing this something which puts the torus, as one might say, in its place, with respect to its own asymmetry. What we see once again being manifested, is this something which is introduced by this very simple signifier which I first brought to you of the interior eight, namely the possibility of an inside field as being still homogeneous with the outside field.

This is such an essential category, so essential to mark, to imprint in your spirit that I believed I had today, at the risk of wearying you, even of wearing you out, to insist throughout one of our lectures. You will see, I hope, its utilisation in what follows.

Seminar 18: Wednesday 2 May 1962

It is not necessarily with the idea of making things easier either for you or for anyone else, that I thought today for this session where we are starting again, at a moment when we have a two month run before us to finish dealing with this difficult subject, that I thought of making of this restart a sort of relay. I mean that for a long time I would have liked, not simply to give one of you a opportunity to speak, but even precisely to give it to Mme Aulagnier. I have been thinking about it for a very long time because it was the day after she read a paper at one of our scientific sessions.

I do not know why some of you who unfortunately are not here, because of a sort of myopia characteristic of certain positions that I would describe moreover as mandarin-like because this term has had a success, thought they saw in this paper some return or other to the letter of Freud while to my ears it seemed that Mme Aulagnier handled with a particular pertinence and acuteness the distinction already long-matured at that time between demand and desire.

There is all the same some chance that one may oneself better recognise one's own posterity than others do. Moreover there was someone who was in agreement with me on this point: it was Mme Aulagnier herself. I regret therefore having taken so long to allow her to speak, perhaps the feeling, an excessive one moreover, of something which is always at our heels putting pressure on us to advance. Precisely today we are for a moment going to make this sort of loop (boucle) which consists in making our way through what in the mind of one of you may respond in a fruitful way to the path that we have taken together. A good while has passed already since the moment that I am evoking, and it is very especially at this intersection, this crossroads constituted in the mind of Mme Aulagnier [with what] I recently (2) said about anxiety, that she came to propose to me some sessions ago that she should intervene here.

It is therefore because of an timeliness which is worth as much as any other one, the feeling of having something to communicate to you and something quite to the point about anxiety, and this in the closest relationship with what she like you has heard about what I am teaching this year about identification, that she is going to bring you something that she has prepared carefully enough to have a full text of it.

She was good enough to share this text with me, I mean that I looked at it with her yesterday and I thought, I must say, that I ought to encourage her to present it to you. I am sure that it represents an excellent middle term (medium) and I mean by that not something which is an average of what, I believe, the most sensitive, the best ears among you can understand, and of the way in which things can be taken up again; resonating with her ear, I will say therefore after she has conceived this text what use I intend to put it to subsequently.

Anxiety and Identification! During the recent Journées Provinciales (a type of congress) a certain number of H interventions centred on the question of knowing if one can define different types of anxiety. But the question was raised as to whether one ought for example to accord a particular status to psychotic anxiety. I will say at the outset that I take a slightly different view: it seems to me that anxiety whether it appears in a normal, neurotic or psychotic subject is a response to a specific and always identical situation of the ego and that this is one of its essential characteristics.

As for what may be called the position of the subject vis a vis anxiety, in psychosis for example, we have seen that unless the relation between affect and verbalisation is more clearly defined a kind of paradox appears, whereby on the one hand the psychotic is seen as someone particularly subject to anxiety; indeed one of the major difficulties in treatment is the mirroring of this anxiety in the analyst, and on the other hand we are told that the psychotic is incapable of recognising his anxiety, that he has alienated himself from it and keeps it at a distance.

The position thus stated is not sustainable unless one tries to go a little further: what in fact does it mean to recognise anxiety? It does not wait to be named and has no need to be named in order to submerge the ego. I do not know what is meant by saying that the subject is anxious without knowing it. We might ask if the property of anxiety is not precisely not to name itself: a diagnosis; a name can only come from the other the one before whom it appears. He the subject he is the affect anxiety, he is totally it, living it, and it is this impregnation, this capturing of his ego which is dissolved there which debars him from the mediation of the word.

At this level we could draw a first parallel between two states which however different seem to me to present two extreme positions of the ego which are as opposed to each other as they are complementary; I mean orgasm. At the moment of orgasm there is the same profound incompatibility between the possibility of living it and that of distancing oneself sufficiently to recognise and define it in the here and now of its occurrence. To say that one is anxious in itself indicates a certain distance from the lived experience and shows that the ego has already acquired a degree of mastery and objectivity vis-a-vis an affect which perhaps from this moment on no longer deserves the name anxiety.

I do not here a need to emphasize the mediating metaphoric role of the word, nor the gaps which exist between an affective experience and its translation into words.

From the moment man puts his affects into words, he makes them into something else; through the word he transforms them into a means of communication causing them to enter into the field of relationship and of intention-ality. The word renders communicable what was lived at the level of the body, which in itself, in the last analysis remains non-verbal. We all know that to say one loves someone has only a slight connection to what is meant by this love as experienced bodily. Lacan reminds us that to tell someone you desire him is to include him in your fundamental phantasy. It is also undoubtedly to bear witness to this fact, the witness of ones own signifier. Whatever may be said on this topic everything indicates a gap which exists between affect as interiorized bodily emotion, as something which has its own profound source, in that which by definition cannot be expressed in words, I speak of phantasy, and the word which thus appears in its function as metaphor.

If the word is the magic and indispensable key which alone grants us access to the world of symbolisation, it seems to me that anxiety occurs precisely at the moment when this key no longer opens any door, when the ego (the me) must come face to face with that which is behind or before all symbolisation, when that which appears is that which is without a name, "this mysterious figure", this place from which a desire arises which one can no longer apprehend, where for the subject a kind of telescoping occurs between phantasy and reality. The symbolic fades giving way to phantasy as such, the ego dissolves and it is this dissolution which we call anxiety.

Certainly the psychotic does not have to wait for the analytic experience in order to know anxiety: it is true that for every subject the analytic situation is a privileged domain in this regard. There is nothing surprising in the statement that anxiety is very closely related to identification. If identification always involves something at the level of desire, - the desire of the subject as it relates to the desire of the Other, - it becomes obvious that a major source of anxiety in analysis is caused by what is in fact the essence of the analytic situation: the fact that the Other in this case is the one whose most fundamental desire is to not desire, someone who by means of this, in allowing every conceivable projection, can unmask their phantasmatic and subjective base, and can cause the subject from time to time to pose the question of the analyst's desire, a desire always presumed never known and for this reason always potentially the place from which anxiety can arise for the analysand.

But before attempting to define the parameters of the anxiogenic situation, parameters which can only be sketched from the baseline of the problem proper to identification, an initial question concerning description can be asked: what do we mean

when we speak of oral anxiety, of castration anxiety, of death anxiety?

To attempt to differentiate these in terms of a type of quantitative grading is impossible. There is no such thing as an anxiety meter. One is not more or less anxious. One either is or is not anxious. The only possibility of sketching an answer at this level lies in taking up one's proper position which is that of the one who alone can define the anxiety of the subject, beginning with whatever it is that this anxiety signals. If it is true as Lacan points out, but it is extremely difficult to speak of anxiety in so far as it is a signal at the level of the subject, it seems certain to me that its appearance designates, signals the Other, as source, as the place from which it surges up, and it is perhaps not unimportant to point out in this connection that there is no affect which we experience as less bearable in others, no other affect is more contagious. Sadism or aggravity for example can arouse opposite feelings in a partner such as masochism or passivity: anxiety can only provoke either flight or an answering anxiety. There is a reciprocity of response here, which raises certain questions.

Lacan rebels against the attempt carried out by several people to find "the content of anxiety": which reminds me of his dictum about something else altogether: in order to pull a rabbit out of a hat one must first put him in. I wonder then if anxiety appears not only when the rabbit comes out but when he has gone off to browse in the grass, when the hat now only represents something which looks like a forus, which surrounds a black hole from which all nameable content has disappeared, faced with which the ego no longer has any point of reference, because the first thing one can say about anxiety is that its appearance is the sign of the momentary collapse of all possible identificatory terms of reference. It is only by starting from here that one can perhaps answer the question I posed earlier concerning the different names given to anxiety, oral etc and not at the level of defining its content, since the property of the anxious subject is to have lost his or her content so to speak.

In other words it seems to me that it is not possible to speak of anxiety as such, to do so seems to me as inaccurate as to try to define an obsessional symptom while remaining at the level of the automatic movement which can represent it. We can learn something about anxiety only if we consider it as the consequence, the result of an impasse of the ego, the sign for us of an obstacle which has occurred between these two fundamental and parallel lines, the convergence of which forms the coping stone of the entire human structure - identification and castration. It is the relation between these two structuring and pivocal lines in different subjects that I will try to sketch out here in order to attempt to define anxiety since in each case it is to this relation that anxiety bears witness.

In the Seminar of April 4th to which I refer Lacan tells us that: "castration can be conceived as a transitional passage from what in him is the natural, become half alien, vacillating support of

desire through this habilitation by the law, by means of which this piece, this pound of flesh is going to become the pledge, the something through which he is going to be designated at the place where he has to manifest himself as desire within the circle of demand".

This transitional passage is what allows us to approach a kind of equivalence penis phallus, in other words that which as "natural support" is the place where desire manifests itself as affect, as bodily feeling, must become, must yield its place to a signifier, because it is only in relation to a subject and not in relation to a partial object penis or otherwise, that the word desire can take on any meaning. The subject demands and the phallus desires says Lacan, the phallus but never the penis. The penis is only the instrument at the service of the signifier itself. If it can be a very indocile instrument it is precisely because as phallus it is the subject whom it designates and for this to happen the Other must recognise it as such, must choose it, not in its role as this natural support but rather in so far as it is as subject the signifier which the Other recognises from his or her own place as signifier.

That which differentiates the masturbatory act from coitus on the plane of Jouissance (they are clearly different but this difference is difficult to explain physiologically) is that coitus in so far as both partners have been able to assume their castration, at the moment of orgasm the subject finds again, not as some would have it a kind of primitive fusion - there is no reason after all why the deepest experience of joy (Jouissance) of which man is capable should be necessarily linked to such a total regression but on the contrary this privileged moment where for an instant he attains his identification, ever elusive but always longed for, where he the subject is recognised by the Other as object of his deepest desire, but also at the same moment because of the Jouissance of the other, where he can recognise him or her as the one who constitutes him as phallic signifier; at this unique instant demand and desire can fleetingly coincide, and it is this which gives to the ego this blossoming of identificatory joy from which Jouissance springs.

It must not be forgotten however that even though demand and desire coincide in this moment, Jouissance carries within itself the source of the most profound dissatisfaction; because if desire is above all desire for continuity Jouissance is by definition something instantaneous and it is this which immediately re-establishes the gap between desire and demand, and the lack of satisfaction which ensures the ceaselessness of demand.

But if there are imitations of anxiety there are even more frequent imitations of Jouissance. This identificatory situation, source of true Jouissance cannot occur if one or both partners has remained fixated to the partial object, locked in a dual situation in which they as subjects have no place: since what is demonstrated by everything linked to castration is that it expresses not so much the fear that the penis will be cut off,

even if this is how the subject verbalises it, as the fear that it will be left to him and that everything else will be cut off; that this penis, this partial object source of pleasure is resented, he will be denied and not accorded recognition as subject. This is why anxiety is closely related to Jouissance, and why one of the most anxiety provoking of situations is the subjects confrontation with the Other at this level.

If we look at the problems encountered by the subject at this level we see that they represent nothing less than the sources of all anxiety. In order to discuss these we must refer to the pre genital modes of relating to objects, to this all important moment in the subject's life where the mediation between the subject and the Other between demand and desire takes place around this very ambiguously defined object which is called the partial object. The relation of the subject to this partial object is nothing other than the relation of the subject to his own body. This primary relationship which is fundamental for every human being is the point of departure and the mould for everything that can be included in the term object relation. Whether the oral, anal or phallic phase is discussed the same coordinates will be encountered. If I choose the oral phase it is because for the psychotic who will be discussed further on this appears to be the fruitful moment for what I have elsewhere called the moment of the inauguration of the psychosis.

How shall we define it? By a demand which from the start is a demand for something else. And by a response which is not only and obviously a response to something else but is, and this seems to me a very important point, that which constitutes a cry, a call perhaps, as demand and as desire. When the mother responds to the baby's crying she recognises it, constituting it as demand, but more importantly she interprets it on the plane of desire: the child's desire to have her near, to take something from her, to attack her or whatever. What is certain is that by her response the Other confers the dimension of desire on the cry of need and that this desire with which the child is invested is always at the beginning the result of a subjective interpretation, a function of maternal desire only, of maternal phantasy. In this way through the unconscious of the Other, the subject enters the world of desire; he will have to constitute his own desire first of all as response; as either acceptance or refusal of the place designated for him in the unconscious of the Other.

It seems to me that the first moment of this key mechanism of the oral relation which is projective identification has its origin in the mother. There is a first projection on the plane of desire which comes from her. The child will have to identify with this or to fight it, to refuse an identification which he may experience as determinant. And this first state of human evolution can also carry with it the revelation for the subject of what it is that his demand conceals. From this moment Jouissance which doesn't wait for phallic organisation to appear can enter the picture carrying with it the revelatory dimension it will always conserve: if frustration reveals the gap between

need and desire, Jouissance on the contrary by responding to that which has not been formulated reveals that which is beyond the demand, in other words desire. What do we see in the oral relation? That demand and response are articulated for both partners around a partial relation - mouth breast. The response at the level of the oral cavity provokes an activity of absorption, a source of pleasure; an external object, the milk will become part of one's own bodily substance. This is what gives it meaning and its importance to this absorption. Starting from this first response the seeking out of this activity of absorption, this source of pleasure will become the object of demand. As for desire it must be sought elsewhere, although it is from this same baseline, this same response, this same experience of the appeasement of need that it will constitute itself.

If the mouth breast relation and the activity of absorbing food represent the numerator of the equation representing the oral relation, there is also a denominator, that which invokes the mother child relationship, and it is here that desire must be situated. No-where else may one more fully appreciate the truth of the proverb: the manner in which one gives is more important than that which one gives. Thanks to or because of this manner of giving, in view of what it reveals of maternal desire, the child will learn the difference between the gift of food and the gift of love. Along with the absorption of food, an introjection occurs, a phantasmatic relationship in which the child and the Other are represented by their unconscious desires. If the numerator can carry a plus sign the denominator can at the same moment carry a minus sign; it is this difference of sign between demand and desire, this place from which frustration arises, that is the origin of every signifier.

From here one can trace the different phases of the evolution of the subject - normal, neurotic, perverse or psychotic. I will try to schematise them here, simplifying them perhaps in a slightly caricatural fashion in order to show the relationship which exists in each case between identification and anxiety.

In the first and most Utopian situation the child finds in the gift of food the gift of love which he desires. The breast and the maternal response can then become symbols of something else. The child enters the symbolic world and can accept the unfolding of the signifying chain. The oral relation as absorption can then be abandoned and the subject evolves in the direction of normal growth.

For this to happen the mother must have taken on board her own castration. A third term, the father must be present for the mother. Only then what she seeks in the child will not be some kind of erotogenic satisfaction which makes of the child the equivalent of the phallus, but a relation in which as mother she is also the wife of the father.

The gift of food will be a symbol of the gift of love for her and because this gift of love will precisely not be the phallic gift

which the subject desires the child will be able to maintain his relation to demand. He will have to seek the phallus elsewhere. He will enter into the castration complex which alone will permit him to identify himself with something other than S. Baird.

If the mother has not taken her own castration on board every object which can be the source of pleasure or the object of demand for the Other risks becoming for her the phallic equivalent she desires. But in so far as the breast has a privileged existence only for the child to whom it is indispensable we see this child - phallus equivalent happening which is centre to the origin of most neurotic structures.

The subject as he develops will be faced with the dilemma of either being or having whatever the bodily object - breast or penis - which has become the phallic support. Either he will identify with the one who has it, but not having acceded to the symbolic, having it will always be having castrated the other. Or else he will renounce having it, he will identify with the phallus as the object of desire of the Other but must also then renounce being himself the subject of desire.

This identificatory conflict between being the agent of castration or the subject who undergoes it is what defines this continual???? this question which is always present at the level of question at the level of identification which is clinically referred to as neurosis.

The third case is what we encounter in perversion. If this latter has been defined as the negative of neurosis, we find the structural opposition also at the level of identification. The pervert is he who has eliminated all identificatory conflict: on the oral plane we could say that in perversion the subject constitutes himself as if the activity of absorption had no other goal than to make of him an object which provides phallic Jouissance for the Other. The pervert neither has nor is the phallus: he is this ambiguous object which serves a desire which is not his: his Jouissance is in this strange situation where the only identification possible to him is as an object which procures the Jouissance of a phallus, but he doesn't know to whom this phallus belongs. One could say that the desire of the pervert is to respond to the demand of the phallus. To take a banal example I would say that in order for the Jouissance of the sadist to appear, another is pleased by the fact that he the pervert makes himself into a whip. If I speak of phallic demand which is a kind of play on words it is because for the pervert the other exists only as the almost anonymous support of a phallus for whom the pervert performs his sacrificial rights.

The perverse response is always a negation of the Other as subject. The perverse identification is always to this object which is the source of the Jouissance for a phallus which is as powerful as it is phantasmatic. Perversion needs to be seen in a context which is wider than the merely sexual. Perversion refers to Jouissance whatever the bodily part involved. If I share Lacan's distrust for what is called genitility it is because

anatomical analysis is dangerous. The most normal seeming intercourse can be as neurotic or as perverse as that which is called a pregenital drive. Normality neurosis or perversion can only be recognised by examining the relation between the ego and the identification which does or does not permit Jouissance.

If one reserves the diagnosis of perversion to sexual perversion only, not only will this get us nowhere since a purely symptomatic diagnosis means nothing, but we will also be forced to recognise that there are very few neurotics who will escape this diagnosis. And it is not only at the level that the solution is to be found of the guilt from which the pervert is said to be exempt - no human being is free from guilt. The only way to approach perversion is to try to define it at the level where it exists, at the level behaviour in relationship.

The obsessional can also be sadistic - for him it means the ongoing presence of an anal relation, a relation where it is a question of possessing or being possessed, a relation where the love which one feels and of which one is the object can only be signified to the subject in terms of a possession which can go so far as the destruction of the object. The obsessional is the one who punishes well because he loves well, he for whom the father's beating has remained the privileged sign of his love and who is always seeking someone to whom he can give or from whom he can receive this beating. But having giving or received it, having assured himself that he is loved he will seek Jouissance in a different type of relation to the same object and whether this relation is oral, anal or vaginal it will not be perverse in the sense I mean, which seems to me to be the only one by which one can avoid extending this label perverse to a large number of neurotics and a large number of our fellow men.

Sadism becomes a perversion when the beating is no longer sought or given as a sign of love but when it is perceived by the subject as the only possibility of procuring Jouissance for a phallus: and the sight of this Jouissance becomes the only possibility offered to the pervert for his own Jouissance.

A lot has been said about the aggressivity of exhibitionism. Flashing is a way of attacking the other undoubtedly, but the exhibitionist is convinced that this aggression is source of Jouissance for the Other. The obsessional when he is exhibitionistic tries to bait the other; he shows what he thinks the other doesn't have but wants to have. The intention is aggressive. Think of the ratman: the father is Jouissance is the father's least of his worries: he shows to the dead father what he thinks the dead father would like to take away from him. This is an aggressive act from which the obsessional draws Jouissance. Whereas the pervert seeks his own Jouissance via that of another. This is what perversion is: this zig-zag journey, this detour by which the ego is always at the service of an anonymous phallic power. He does not care who is his object, it is enough for him that it should be capable of Jouissance that he can make of it a support of this phallus to which he is identified, that it can serve as an object presumed to be capable of procuring Jouissance

for this phallus. This is why, contrary to what one finds in neurosis, perverse identification like its particular type of object relation is something which is striking in its stability, its unity.

We now reach our fourth category which is the one most difficult to grasp: psychosis.

The psychotic is a subject whose demand has never been symbolised by the Other, for whom the real and the symbolic, phantasy and reality have never been demarcated because he has never acceded to the imaginary, the third dimension which alone allows a differentiation between these two different levels. In order to simplify things let us situate ourselves at the very first moment of the history of the subject, before the oral relation at the moment of conception.

The first amputation undergone by the psychotic happens before his birth: for his mother he is a part of her own metabolism; all paternal participation is denied by her, is unacceptable. Throughout the pregnancy the child is the partial object which will fill up the phantasmatic lack on a bodily plane. From birth the role assigned to him will be to be the witness of her negation of castration.

The child contrary to what is often said is not the mother's phallus: he is the proof (witness) that the breast is the phallus, which is not the same thing. So that the breast may be the phallus and an all powerful one, the response it brings to the child must be perfect and total. The demand of the child cannot be recognised as anything that is not demand for food, the dimension of desire at the level of the subject must be denied; what characterizes the mother of the psychotic is a total interdiction which blocks the child from becoming subject to any desire.

One can see from this moment how the psychotic's particular relation to the word will develop. From the beginning it will be impossible for him to maintain his relation to the demand: if he is responded to only as a mouth to be fed, only as a partial object, every demand, even as it is being formulated will carry within it the death of desire. Since he has not been symbolised by the Other he will be drawn himself to make the symbolic and the real coincide in the response. Since no matter what he demands, it is food which is given to him, it will be food as such which will become for him the master signifier. From that moment the symbolic will erupt into the real: instead of the gift of food finding its symbolised equivalent in the gift of love, for him every gift of love can only be signified by oral absorption. To love or to be loved will be translated by him into oral terms: to absorb or to be absorbed. For him there will always be a fundamental contradiction between demand and desire: either he maintains his demand and his demand destroys him as subject of desire: he must alienate himself as subject in order to make himself a mouth, an object to be fed: or else he will try

one way or another to constitute himself as subject and to do this he will find himself obliged to alienate that body part which is the source of pleasure and the origin of his response of himself which is for him incompatible with any attempt at autonomy.

The psychotic always finds himself forced to alienate either his body as support of the ego or a body part as support of the possibility of a Jouissance. If I do not use the term identification here it is precisely because I do not think it is applicable in the case of psychosis. In my view identification implies the possibility of a relation to the object where the desire of the subject and the desire of the Other are in a conflictual situation but exist as the two constitutive poles of the relation (to the object). In psychosis the Other and his desire have to be defined at the level of a phantasmatic relation of the subject to his own body. I will not go into this since it will take us too far from the subject of our discussion which is anxiety. Contrary to what may be believed it is of anxiety that I have been speaking all along. As I said at the beginning it is not possible to address the subject of anxiety without taking into account the parameters of identification.

What has been seen in all the cases discussed, whether normal neurotic or perverse, identification can only happen in relation to what the subject imagines rightly or wrongly to be the desire of the Other. In the normal, neurotic or perverse subject it is always a matter of identifying oneself in accordance with or in opposition to what one thinks is the desire of the Other. As long as this desire can be imagined, phantasized, the subject will find there the necessary reference points in order to define himself, either as the object of the desire of the Other or as an object refusing to be the desire of the Other. In either case he will be able to locate himself, to define himself.

But from the moment when the desire becomes something mysterious, undefinable, the subject discovers that it is precisely this desire of the Other which constitutes him as subject; what he will encounter faced with this void is his fundamental phantasy. To be the object of the desire of the Other is only bearable in so far as we can name this desire, can shape it in terms of our own desire. To become the object of a desire we can no longer name, is to become oneself an object without a name having lost all possible identity: to become an object whose insignia no longer means anything since they have become undecipherable for the Other. This precise moment when the ego is reflected in a mirror which gives back an image which has no identifiable meaning - this is anxiety. In calling it oral, anal or phallic we are simply trying to define which insignia the ego has donned in order to be recognised. If anxiety is the affect which most easily provokes a reciprocal response it is because from this moment we become for the Other the one whose insignia are equally mysterious, equally inhuman. In anxiety it is not just the ego which is dissolved, the other also dissolves as support of identification. Jouissance and anxiety are the two extreme positions in which the ego can situate itself: in the first the

ego and the Other for an instant exchange insignia, recognise each other as two signifiers whose shared Jouissance assures a momentary identity of desire: in anxiety the ego and the Other are dissolved, annulled in a situation where desire disappears because it cannot be named.

In psychosis things are a little different. Here too anxiety is nothing other than the signal of the loss of all possible reference points for the ego. But the source from which this anxiety arises is indigenous: it is the place from which the desire of the subject can appear - it is his desire which is the privileged source of all anxiety for the psychotic.

If it is true that it is the Other who constitutes us by recognising us as object of desire, if the response of the Other makes us realise the gap which exists between demand and desire and if it is through this gap that we enter into the world of signifiers, then for the psychotic the Other is the one who has never signified anything other than a hole, a void at the very centre of his being. The interdiction regarding desire which he has experienced means that his response has caused him to register not a gap but a fundamental antimony between demand and desire. From this gap which is not just a gap but a gaping pit what appears is not the signifier but the phantasy, that which causes the telescoping of the symbolic and the real which we call psychosis.

For the psychotic - if I can put it simply - the Other is introjected at the level of his own body, at the level of everything which surrounds the primordial absence which is the only thing which designates him as subject.

For him anxiety is linked to specific moments where out of this hole something appears which can be called desire: because in order to assume this desire the subject must situate himself in the only place from which he can say "I" - in other words must identify with this hole which because of the interdiction of the Other is the only place where he can be recognised as subject. Every desire can only throw him back on either a negation of himself or an negation of the Other.

But in so far as the Other is introjected at the level of his own body it is this introjection alone which allows him to live. All negation of the Other would be for him a self mutilation which can only throw him back onto his own fundamental drama.

If our silence helps to reveal the sources of anxiety in the neurotic, our presence, our word does so with the psychotic. Everything which causes him to lose awareness of our existence as separate from him, as autonomous subjects who can recognise him as subject, releases his anxiety. So long as he talks, he repeats a monologue which situates us at the level of this introjected Other which constitutes him, but if he should begin to talk to us in so far as we as object may become the place where he must recognise his desire, his anxiety will be released: because to desire means to constitute oneself as subject and for

him the only place where he can do that is the place which refers him back to this gaping hole.

Here too one can see that anxiety appears at the moment when desire makes of the subject something which is a lack of being, a failure to name oneself.

I have not spoken of phantasy which is intimately related to both identification and to anxiety. I could have said that anxiety appears at the moment when the real object can only be grasped in its phantasmatic meaning, that it is from this moment, since all possible identification of the ego has dissolved that anxiety appears.

I will end with a short case history in order to give you a clinical example of the sources of anxiety in the psychotic. I will not go into detail except to say that this is a schizophrenic suffering from delusions who has been frequently hospitalized. The first sessions were given over to an account of his delusions, a fairly classic one which he called the problem of the robot man. Then in one session where by chance communication with others and the word were being discussed he explained that what he cannot bear is "the form of the demand", that "the handshake is an improvement on civilizations which use verbal salutations, because the word falsifies things, blocks understanding. The word is like a turning wheel - everyone sees a different part at different moments so communication is always false; there is always a dialogue".

In this same session at the moment when he broaches the problem of the woman's word he suddenly says: "what disquiets me is what they say about amputees, that they can feel things with the limb they no longer have:" at this moment this man whose speech even in his delusion is extremely precise, begins to fumble, to search for words and finally comes out with this: "a ghost would be a man without limbs and without a body who by his intelligence alone could recognise a false sensation in a body he doesn't have. This makes me very uneasy."

"Would recognise a false sensation in a body he doesn't have". This phrase took on its meaning in the following session when he announced that he wanted to stop, that the treatment was unhealthy and dangerous. What was unhealthy and dangerous was "that I realised you wanted to seduce me and that you could succeed". What he realised from these false sensations in a body he doesn't have was that he might desire. Then he would have to recognise, to assume this lack which is his body. He would have to look at what is unbearable for man if it has not been symbolised - castration as such.

In this same session he himself expressed better than I could the source of his anxiety: "you are afraid to look at yourself in a mirror, you don't really know what you will see there. It is better if you buy a gilded mirror."

One has the impression that he wants to be sure that the changes are caused by the mirror.

As you see anxiety appears at the moment when he fears I may become an object of desire; from that moment the arousal of his own desire would imply for him the necessity of taking on board the fundamental lack which constitutes him.

From the moment anxiety appears, his position of ghost, as robot is no longer possible. He risks being no longer able to deny the false sensations of a body he cannot acknowledge. What causes his anxiety is the precise moment when faced with the eruption of his desire he wonders what image of himself the mirror will reflect back to him; he knows it may be a void, an unnameable# something, something which will render impossible any neutral recognition, and which we the involuntary spectators of this drama call anxiety.

Before trying to examine the place of this discourse I would like some of the people whom I saw with different interrogative, expectant expressions, expressions which became more precise at one or other turning point of Mme Aulagnier's discourse, to simply indicate the suggestions, the thoughts produced in them at one or other detour of this discourse as a sign that this discourse has been heard. I only regret one thing: it was read. This will provide me with supports on which I will be able to accentuate my commentary more precisely.

M Audouard

What struck me by way of association, is really the clinical example that you brought in at the end of your presentation, it is this sentence of the patient about the word which he compares to a wheel which different people never see the same part of. This seems to me to illuminate everything that you said and to open up - I really don't know why - a whole broadening of the themes that you have presented.

I think I have more or less understood the meaning of the presentation; I am not used to schizophrenics, but as regards neurotics and perverts anxiety in so far as it cannot be the object of symbolisation because it is precisely the mark that symbolisation has not been able to take place and to symbolise oneself is really to disappear into a sort of non-symbolisation from which the summons of anxiety comes at every instant. It is obviously something extremely rich but which perhaps on a certain logical plane would demand some clarifications. How in fact is it possible that this fundamental experience which is in a way the negativism of the word should come to be symbolised and what happens then in order that from this central hole there should spring forth something that we have to understand. Indeed how is the word born? What is the origin of the signifier in this precise case of anxiety in so far as it cannot express itself. For anxiety in so far as it expresses itself? There is perhaps there a movement which is not unrelated with this wheel which

turns, which would perhaps need to be made a little clearer and more precise.

M Vergotte

I was wondering if there were not two sorts of anxiety: Mme Aulagnier spoke of castration-anxiety: the subject is afraid that it's going to be taken away from him and that he will be forgotten as a subject, here is the disappearance of the subject as such; but I was wondering if there were not an anxiety where the subject refuses to be subject, if for example in certain phantasies he wants on the contrary to hide the hole or the lack. In Mme Aulagnier's clinical example the subject refuses his body because the body reminds him of his desire and his lack; in the example of castration anxiety you said rather: the subject is afraid that he will be misrecognised as subject. An anxiety has therefore the two possible meanings: or he refuses to be subject. There is also the other anxiety where he has, for example in claustrophobia, that there he is no longer a subject, that on the contrary he is closed in, that he is in a closed world where desire does not exist; he can be in a state of anxiety before his desire and also before the absence of desire.

Aulagnier

Do you not think that when one refuses to be a subject it is precisely because one has the impression that for the Other one cannot be subject except by paying for it with one's castration, I do not believe that the refusal to be subject is to be really a subject.

Lacan

We are right at the heart of the problem. You see immediately here the point at which one becomes confused. I find that this discourse is excellent in so far as the handling of certain of the notions that we find here has allowed Mme Aulagnier to highlight, in a fashion which would not have been possible for her otherwise, several dimensions of her experience. I am going to take up again something that appeared remarkable to me in what she produced. I say right away that this discourse seemed to me to remain at a half-way point. It is indeed a sort of conversion, you should have no doubt about it, that I am trying to obtain from you through my teaching, which is not, God knows, after all such a unique pretention in history that for it to be seen as exorbitant. But it is certain that a whole part of Mme Aulagnier's discourse and very precisely the passage at which, with an eye to intelligibility, her own as well as that of those to whom she was speaking, to whom she believed she was speaking, she goes back to formulae which are the ones against which I warn you, I direct you, I put you on your guard, and not simply because in my case it is a sort of tic or aversion, but because their coherence with something which must be radically abandoned (22) always shows itself every time they are used, even knowingly.

The idea, for example, of any kind of antinomy whatsoever between word and affect, even though it may be empirically verified in experience, is nevertheless not something on which we can articulate a dialectic, if what I am trying to do before you has a value, namely allows you to develop as far as possible all the consequences of the effect that man is an animal condemned to dwell in language. Hence, we cannot in any way hold affect to be anything whatsoever without ending up in some sort of primariness (primarite). No significant affect, none of those we have to deal with from anxiety to anger and all the others, can even begin to be understood except within a reference in which the relationship of x to the signifier is primary. Before emphasizing the distortions, I mean that with respect to certain breakthroughs which would be the next stage, I want of course to mark the positive aspect of what was already permitted to her by the simple usage of these terms in the forefront of which are those which she made use of with correctness and skill: desire and demand. It is not enough to have heard about this which - if one makes use of them in a certain fashion, but they are not all the same such esoteric words that anyone feels that they cannot use them - it is not enough to use these terms: desire and demand, in order to apply them correctly. Certain people have tried it recently and I am not sure that the result was in any way either brilliant - which after all would only be of secondary importance - or even had the slightest relationship with the function that we give to these terms.

This is not the case for Mme Aulagnier, but something that allowed her to attain at certain moments a tone which manifested a sort of conquest, even if only in the form of the question posed. The handling of these terms allows us to designate the first very impressive opening that she gave us. I would point out to you what she said about orgasm or more exactly about loving jouissance.

If I may be allowed to address myself to her as Socrates might address himself to some I would say to her that she proves that she knows what she is talking about. That she does it as a woman, this is what traditionally seems to be self-evident. I am less sure about it: rare are the women, I would say, whatever about knowing, who are able to talk while knowing what they are saying about the things of love. Socrates (23) said that undoubtedly he could bear witness to that himself, that he knew. The women are therefore rare, but you should clearly understand what I mean by that: the men are even more so.

As Mme Aulagnier told us, in connection with what loving jouissance is, in rejecting once and for all this famous reference to fusion which should alert us who have given a quite archaic sense to this term fusion, you cannot at the same time require that it is at the end of a process that one arrives at a moment that is qualified as unique, and at the same time suppose that it is by a return to some primitive differentiation or other. In short, I will not reread her text because I do not have the time, but on the whole I do not think it would be unprofitable for this text, to which I am certainly far from

giving a mark of 100 percent, I mean of considering as a perfect discourse, to be considered rather as a discourse defining a rung starting from which we could situate the progress to which we could refer ourselves, to something which was touched on or in any case perfectly grasped, caught, circumscribed, understood by Mme Aulagnier.

Of course, I am not saying that she is giving us her last word here, I would even say more: on several occasions she indicates the points where it would seem necessary to her to advance to complete what she is saying and of course a great part of my satisfaction comes from the points that she indicates. They are precisely the very ones which could be turned round, as I might say. She designates these two points in connection with the relationship of the psychotic to his own body on the one hand - she said that she had many things to say, she indicated a little bit of it to us - and on the other hand in connection with the phantasy where the obscurity in which she left it would appear to me sufficiently indicative of the fact that this darkness is rather general in groups. This is one point.

The second point that I find very remarkable in what she contributed to us, is what she contributed when she spoke to us about the perverse relationship. Not of course that I subscribe at every point to what she said on this subject, which is really of an unbelievable daring. It is to congratulate her highly for having been in a position, even if it is a step to be rectified, to do it all the same; to describe this step as I should, I would say that it is the first time, not simply in my circle - and I am delighted that someone has preceded me in this - that something has come to the fore, a certain fashion, a certain tone in speaking about the perverse relationship which suggests to us the idea which is properly speaking the one that has prevented me (24) from speaking about it up to now because I do not want to appear to be the one who says: everything that has been done up to the present isn't worth buttons. But Mme Aulagnier, who has not the same reasons for modesty as I have, and moreover who says it in all innocence, I mean who has seen perverts and who has interested herself in them in a truly analytic fashion, begins to articulate something which, from the very fact of being able to present under this general form, I repeat, an unbelievably audacious one that the pervert is someone who makes himself object for the jouissance of a phallus whose ownership (appartenance) he does not suspect: he is the instrument of the jouissance of a god. That means when all is said and done, that this deserves some sharpening, some rectification by directive manoeuvres and, in a word, that this poses the question of reintegrating what we call the phallus, that this poses the urgency of the definition of phallus - there is no doubt about it - since that surely has the effect of telling us that if a diagnosis of perverse structure ought, for us analysts, to have a meaning, we must begin by throwing out the window everything that was written from Kraft-Ebing to Havelock Ellis and everything that has been written in any supposedly clinical catalogue whatsoever of the perversions. In short, there is to be overcome on the plane of the perversions, in short, we have to overcome

this sort of distance taken under the word clinical, which in reality is only a way of failing to recognize what is absolutely radical, absolutely open in this structure to whoever knows how to take this step which is precisely the one I require of you, this step of conversion which allows us to be at the point of view of perceiving where we know the absolutely universal thing meant by this perverse structure.

If I evoked gods it is not for nothing, because I could just as well have evoked the theme of metamorphoses and the whole mystical relationship, a certain pagan relationship to the world which is the one in which the perverse dimension has I would say its classical value.

It is the first time that I have heard someone speaking in a certain tone which is really decisive, which is the opening into this field where precisely we need it at the moment that I am going to explain to you what the phallus is.

The third thing, is what she told us in connection with her experience of psychotics. I do not need to underline the effect that this may have. I mean that Audouard undoubtedly bore witness to it. There again what appeared outstanding to me, is precisely the way in which this also opens up this psychotic (25) structure as being something in which we ought to feel ourselves at home. If we are not capable of grasping that there is a certain degree, not an archaic one to be situated somewhere around birth, but a structural one, at the level of which desires are properly speaking mad, if for us the subject does not include in its definition, in its primary articulation, the possibility of psychotic structure, we will never be anything but alienists. But how can one not sense living, as happens all the time to those who come to hear what is said here at this seminar, how can we not grasp that everything that I began to articulate this year in connection with the surface structure of the -system and the enigma about the way in which the subject can gain access to his own body is that this does not happen just by itself, which is something everyone throughout the ages is perfectly aware of because this famous and eternal distinction of disunity or unity of body and soul is always after all the aporia point on which all the philosophical articulations have been shipwrecked. And why should it not be possible for us analysts, precisely, to find the passage? Only this requires a certain discipline and in the first place what you must know in order to be able to speak about the subject is the following which you can never get into your heads enough in the brutal form in which I am going to announce it, it is that the subject is nothing other than the following, than the consequence of the fact that there is signifier and that the birth of the subject depends on the fact that he cannot but think of himself as excluded from the signifier which determines him. This is the value of the little

cycle that I introduced to you the last time and which we have not finished hearing being spoken about because, in truth I will all the same have to unfold it more than once before you in order for you to see where exactly it leads



us. If the subject is only that: this part excluded from a field entirely defined by the signifier, if it is only starting from that that everything can come to birth, one must still know at what level one makes this term subject intervene. And despite herself, because it is to us that she is speaking and because it is to her and because there is still something not yet learned, assumed all the same when she speaks of this choice for example that there is between being a subject or an object in connection with the relationship to desire, well then, despite herself, Mme Aulagnier allows herself to slip into re-introducing into the subject the person with all the subsequent dignity that you know we give it in our enlightened times: personology, personalism, personality and all that follows from it, a (26) convenient approach which everyone knows we live in the middle of. Never has there been so much talk about the person. But after all as our work is not a work which ought to interest itself much in what is happening in the public square, we have to interest ourselves in the subject in a different way. Here then Mme Aulagnier called to her aid the term, parameters of anxiety. Well then, here all the same in connection with person and personology, you see a rather considerable work which took me some months, a work of observations on the discourse of our friend Daniel Lagache. I would ask you to consult it, I would ask you to consult it to see the importance in the articulation that she gives us about the function of anxiety and this kind of stifling that it is supposed to constitute at the level of the word, the importance that should normally have been taken in her presentation by the function $i(o)$, in other words the specular image which is certainly not at all absent from her presentation because when all is said and done she ended up by dragging her psychotic in front of his mirror for us, and this is why, it is because this psychotic came there all by himself, it is here therefore that she quite correctly made her rendezvous with him. And to give you something to smile about I would inscribe in the margin of the remarks which she admired so much in what she quoted, these four little verses inscribed at the bottom of a plate I have at home:

"A Mina son miroir fidele
Montre, hélas, des **traits** allonges
Ah ciel, oh Dieu, s'écrit-elle
Comme les miroirs sont changes

(To Mina, alas, her faithful mirror shows a long face
Oh heavens, oh goodness, she cries, how mirrors have changed)

This effectively is what your psychotic says, showing here the importance of the function, not of the ego-ideal, but of the ideal ego as the place where there come to be formed properly ego-type identifications, this as the place where anxiety is produced, anxiety which I qualified for you as a sensation of the desire of the Other. To bring this sensation of the desire of the Other back to the dialectic of the subject's own desire confronted with the desire of the Other, here is the whole distance between what I initiated and the already very

efficacious level at which there is sustained the whole development of Mme Aulagnier.

But, as she says, this sort of conflictual level which is that of the reference of two already constituted desires in the subject, can in no way suffice for us to situate the difference, the distinction that exists between the relationships of desire for example at the level of the four kinds or types which she defined for us under the terms of: normal, perverse, neurotic, psychotic.

(27) That the word, in effect, is lacking something in connection with anxiety, lies in the fact, which we cannot fail to recognise as one of the absolutely essential parameters, that it cannot designate who is speaking, that it cannot refer to this point i(o) the I of the discourse itself, the I which in the discourse designates itself as the one who is actually speaking and associates him with this image of mastery which finds itself vacillating at that moment. And she could have been reminded of this because I noted in what she took as a point of departure in connection with the seminar of 4 April, remember the vacillating image that I tried to set before you of my obscure confrontation with the praying mantis and the fact that, if I spoke at first about the image which was reflected in this eye, it was to say that anxiety begins from this essential moment when this image is lacking. No doubt the small o which I am for the phantasy of the other is essential, but where there is lacking - Mme Aulagnier does not fail to recognize it, because she reinstates it in other passages of her discourse - the mediation of the imaginary - this is what she means, but it is not yet sufficiently articulated - it is the i of o which is lacking and which is functioning there.

I do not want to go any further because you are well aware that it is a matter of nothing less than taking up again the discourse of the seminar, but it is here that you ought to sense the importance of what we are introducing. It is a matter of what is going to make the link in the signifying economy of the constitution of the subject at the place of his desire. And you should here glimpse, tolerate, resign yourself to something which requires from us something which appears just as far from our ordinary preoccupations, indeed from anything that one could with decency demand of honourable specialists like you who do not come here all the same to do elementary geometry. Reassure yourselves, it is not geometry, because it is not metric, it is something about which geometers have not had the slightest idea up to the present: the dimensions of space. I would go as far as to tell you that M Descartes had no idea about the dimensions of space.

The dimensions of space, it is something of a different aspect which was decided, valorized by a certain number of jests made about this term as the fourth or the fifth dimension and other things which have a quite precise and mathematical meaning, but which it is always amusing to hear spoken about by incompetents, so that when one speaks about it one always has the feeling that one is engaging in what is called science fiction and this has all the same a rather bad reputation.

(28) But all the same you will see that we have our word to say about it. I began to articulate it in this sense that psychically I told you we only have access to two dimensions; for the remainder there is only an outline, a beyond. As regards what comes from experience, in any case as a research hypothesis which can be of use to us for something, to be willing to admit that there is nothing well established beyond - and it is already sufficiently rich and complicated - the experience of the surface. But this does not mean that we cannot find in the experience of the surface alone the testimony that it, the surface, is plunged in a space which is not at all the one that you imagine with your visual experience of the specular image. And in a word, this little object which is nothing when the most elementary knot, not the one which I

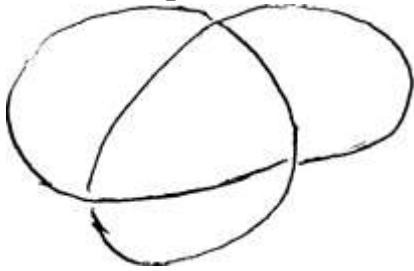

only made because I could not have woven for myself a piece of string which would close on itself, simply this (schema) the most elementary knot, the one which is traced out like that, suffices to carry with itself a certain number of questions that I am introducing in telling you that the third dimension is absolutely not sufficient to account for

the possibility of that. Nevertheless a knot all the same, is something which is within everybody's range, it is not within everybody's range to know what he is doing in making a knot, but after all this has taken on a metaphorical value: the knots of marriage, the knots of love. Knots sacred or not, why do people speak about them?

They are quite simple, elementary modes, of putting within your reach the habitual (usual) character if you wish to apply yourself to it, and once it becomes habitual, the possible support of a conversion which, if it is realised will clearly show all the same retrospectively that perhaps these terms must have something to do with these references to structure that we need to distinguish what happens for example at the steps that Mme Aulagnier has divided in going from the normal to the psychotic. At this point of junction where the subject constitutes for himself the image of the knot, the fundamental image, the image which allows the mediation between the subject and his desire, can we not introduce very simple distinctions, and, you will see, ones which are quite utilisable in practice, which allow us to represent for ourselves in a simpler fashion and one which is less a source of antinomy, of aporia, of confusion, of labyrinth finally, that what we have here at our disposal, namely this summary notion for example of an inside and an outside which in effect appears to be self-evident starting (29) from the specular image and which is not at all necessarily the one which we are given in experience.

Seminar 19: Wednesday 9 May 1962

The last time, we heard Mme Aulagnier speaking to us about anxiety. I paid her discourse the homage it deserved, as the fruit of work and reflection that are well oriented. I marked at the same time the degree to which a certain obstacle, which I situated at the level of the paper itself, is always the same: the one which arises every time we have to speak about language.

Undoubtedly the sensitive points, the points which deserve to be rectified in what she told us, are precisely those where putting the accent on what exists: the unsayable (l'indicible), she made of it the index of a heterogeneity of what precisely she is aiming at as the "not being able to be said", even though what is involved in the business when anxiety is produced is precisely to grasp its link with the fact that there is a said (du dire) and an able to be said. This is why she is unable to give its full value to the formula that the desire of man is the desire of the Other. It is so not with reference to a supposedly renascent third, the more central subject, the subject identical to itself, the Hegelian self-consciousness which would be there to bring about the mediation between two desires which it is supposed in a way to be confronted with: his own proper one as an object, and the desire of the Other, and even if it were to give primacy to this desire of the Other it would have to situate, to define its own desire in a sort of reference, of relationship or non-dependence on this desire of the Other.

Of course on a certain level at which we could always remain, there is something of this order, but this something is precisely that thanks to which we avoid what is at the heart of our experience and what must be grasped. And that is why, it is for that reason that I am trying to forge for you a model of what (2) must be grasped. What must be grasped, is that the subject which interests us is desire. Of course this only takes on a meaning when we have begun to articulate, to situate at what distance, through what mediation, which is not that of an intermediary screen but of constitution, of determination, we can situate desire.

It is not that demand separates us from desire as if it were only a matter of setting demand aside to find it. Its signifying articulation determines me, conditions me as desire. This is the long path that I have already made you take. If I have made it so long, it is because it is necessary that it should be so in order that the dimension that this presupposes should make you go

through in a way the mental experience of apprehending it. But this desire thus transported, put off to a distance, articulated as such not beyond language as if it were due to the impotence of this language, but structured as desire through that very potency itself, this is what it is now a matter of rejoining in order that I may manage to make you conceive of, grasp - and there is in the grasp, in the Begriff, something tangible - something of a transcendental aesthetic which ought not to be the one accepted up to now because it is precisely from the one accepted up to now that the place of desire up to the present has been hidden.

But this is what explains for you my attempt, which I hope is successful, to lead you along paths which are also those of the aesthetic in so far as they try to catch hold of something which has not been seen at all in all its relief, in all its fecundity at the level not so much of spatial as topological intuitions, because it must be that our intuition of space does not exhaust everything which is of a certain order because moreover those who are best qualified to occupy themselves with it, the mathematicians, try from every angle and succeed in going beyond intuition.

I am leading you along this path when all is said and done to say things with words which are slogans (des mots d'ordre): it is a question of escaping from the pre-eminence of the intuition of the sphere in so far as it in a way dominates our logic in a very intimate way, even when we do not think about it. Because of course if there is an aesthetic called transcendental which interests us, it is because it is what dominates logic. It is for this reason that to those who say to me: "Could you not really tell us things, make us understand what is happening in a neurotic or in a pervert and how it is different, without going through your little tori and other detours?", I would respond that it is (3) nevertheless indispensable, just as indispensable and for the same reason because it is the same thing, as doing logic, because the logic in question is not something empty. Logicians, like grammarians, dispute among themselves and in so far as of course in going into the field of these disputes we can only evoke them with discretion in order not to lose ourselves in them, but all the confidence that you have in me reposes on the following: it is that you credit me with having made some effort not to take the first path that came to me and to have eliminated a certain number.

But all the same, to reassure you, there comes to me the idea of pointing out to you that it is not a matter of indifference to put in the forefront in logic the function of the hypothesis for example or the function of assertion. In what is called an adaptation Ivan Karamazov is made to say in the theatre:

"If God does not exist, then everything is permitted".

You refer to the text. You read - and moreover if I remember properly, it is Aliocha who says that as it happens -:

"Since God does not exist, then everything is permitted".

Between these two terms there is the difference between the "if, si" and the "since, puisque", namely between a hypothetical logic and an assertive logic, and you will say to me: a logician's distinction, what is the interest of that to us?

It interests us to such a degree that it is by presenting things in the first fashion that at the final term, the Kantian term, the existence of God is maintained for us. Since in short it is all there: since it is clear that everything is not permitted, therefore in the hypothetical formula it is imposed as necessary that God exists. And this is why your daughter is mute and why in the teaching articulation of free thinking there is maintained at the heart of the articulation of all valid thinking about the existence of God, as a term without which there would not even be a means of advancing something in which there is grasped the shadow of a certainty, and you know - something I thought I should remind you a little about on this subject - that Descartes' approach cannot pass along any other paths.

It remains that it is not necessarily by pinning the term atheistic on it that one will best define our project, which is perhaps to try to make pass through something else the consequences involved for us in this fact of experience, that (4) some things are permitted (qu'il y ait du permis). Some things are permitted because there are prohibitions, you will tell me, quite satisfied to rediscover here the opposition of a and non-a, of white and black. Yes, but this is not enough, because far from the permitted and the prohibited exhausting the field, what it is a matter of structuring, of organising is how it is true that they determine one another very closely, while at the same time leaving open a field which not alone is not excluded by them but makes them rejoin one another, and in this movement of torsion, as one might say, gives its shape properly speaking to what sustains the whole, namely the shape of desire. In a word that desire is set up in transgression is something everyone feels, everyone clearly sees, everyone has the experience of that, which does not mean, could not even mean that all that is involved here is a matter of a frontier, of a limit traced out. It is beyond the frontier that has been broken through that desire begins.

Of course, this often appears to be the shortest way, but it is a hopeless way. It is elsewhere that the path of passage is taken. Even though the frontier, that of prohibition, does not signify either making it descend from heaven and from the existence of the signifier. When I speak to you about the law, I speak to you about it like Freud, namely that, if one day it arose, no doubt it was necessary that the signifier should immediately emit its mark, its stamp, its form, but it is all the same from something which is an original desire that the knot was able to be formed in order that there should be founded together the law as limit and desire in its shape.

It is this that we are trying to depict in order to enter into detail, to retrace again this path which is always the same, but which we tighten around a knot that is more and more central

whose umbilical aspect I do not despair of showing to you. We are taking the same path and we are not forgetting what is least situated for us in terms of reference which are supposed to be either legalist, or formalist, or naturalist, it is the notion of the small o in so far as it is not the imaginary other that it designates in so far as we identify ourselves to him in our ego-style miscognition. This is i of small o, $i(o)$, and there also we find the same internal knot. Which means that it seems to be quite simple: that the Other is given to us in a imaginary form, is not so because it is precisely this Other that is involved when we speak about the object. It must not to be said at all that this object is quite simply a real object, that it is precisely no doubt the original object of desire as such but that (5) we cannot say that until after we have grasped, understood, apprehended what it means that the subject in so far as he is constituted as dependence on the signifier, as beyond the demand, is desire.

Now, it is this point of the loop (boucle) which is not yet at all secure and that is where we are advancing and it is for this reason that we recall the usage that we have made up to now of small o. Where have we seen it, where are we first going to designate it? In the phantasy where quite clearly it has a function which has some relationship with the imaginary: let us call it the imaginary value in the phantasy. It is quite other than simply projectable in a intuitive fashion into the function of the lure as it is given to us in biological experience for example. It is something different and this is what you are reminded of by the formalisation of phantasy as being established in its relationship by the ensemble: S desire of o, S o and the situation of this formula in the graph which shows homologically, by its position at the upper level which makes it the homologue, of the i of o of the lower level in so far as it is the support of the ego, little e here, just as S desire of o is the support of desire.

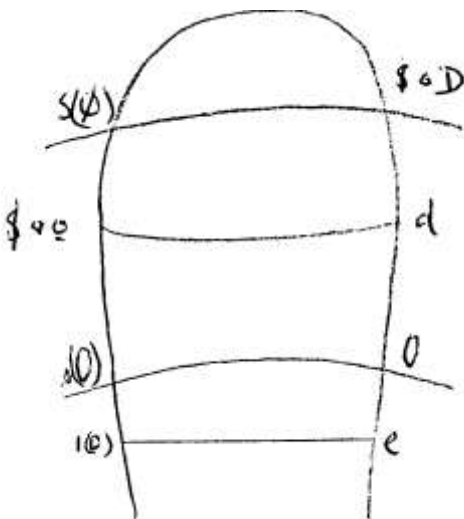

What does that mean? It is that the phantasy is there where the subject grasps himself in what I highlighted for you as being in question at the second level of the graph in the form taken up at the level of the Other, in the field of the Other, at this point here of the graph of the question: "What does it (5a) want?" which is moreover the one which will take on the form: "What does he want?" if someone has been able to take the place projected by the structure of the locus of the Other, namely of this locus which is that of the master and the guarantor. This means that in the field and the the phantasy has a homologous

trajectory of this question, function to that of i of o, of the ideal ego, the imaginary ego

on which I repose, that this function has a dimension, highlighted no doubt on some occasion, and even more than once, which I must here remind you anticipates the function of the ideal-ego which is marked for you in the graph by the fact that it is a sort of return which all the same allows a short-circuiting with respect to the intentional manoeuvres of (6) the discourse considered as constitutive at this first level of the subject, that here before signified and signifier recross one another he has constructed his sentence, the imaginary subject anticipates the one he designates as ego. It is the very one no doubt that the I of the discourse supports in its function as shifter. The litteral I in the discourse is no doubt nothing other than the very subject who is speaking, but the one whom the subject designates here as his ideal support is in advance, in a future perfect, the one that he imagines will have spoken: "he will have spoken", at the very basis of the phantasy there is even a "he will have wanted".

I will not push any further. So this opening or this remark can only be located because at the beginning of our path in the graph I held a dimension of temporality to be implicated. The graph is made to show already this type of knot that we are for the moment in the process of seeking at the level of identification. The two curves intersect one another in the contrary direction, showing that synchronicity is not simultaneity, already indicating in the temporal order what we are in the process of trying to knot together in the topological field. In short, the movement of succession, the signifying kinetics, this is what supports the graph. I recall it to you here to show you the import of something that I did not take into account so much in a doctrinal way, this temporal dimension, which contemporary phenomenology feathers its nest with.

Because in truth, I believe that there is nothing more mystifying than to speak without rhyme or reason about time. But it is already here that I make a note to indicate to you here that we will have to come back on it to constitute no longer a kinetics but a temporal dynamics, which is something we cannot do until we have overcome what it is a matter of doing for the moment, namely the spatialising topological mapping out of the identificatory function. That means that you would be wrong to stop at anything whatsoever that I have already formulated, that I thought it well to formulate also in an anticipatory fashion on the subject of anxiety with the complement that Mme Aulagnier was kind enough to add to it the other day as long as there is not effectively restored, referred back, brought back into the field of this function something I have already always pointed out, I mean ever since the article on the mirror stage which distinguishes the anxiety relationship from the aggressive relationship, namely temporal tension.

Let us come back to our phantasy and to small o to grasp what is involved in this "imaginification" which properly has its place in the phantasy. It is quite sure that we cannot isolate it in its correlation to $\$$ because of the fact that the emergence of the function of the object of desire as small o in the phantasy

is correlative to this sort of vanishing, fading of the symbolic (7) which is the very one that I articulated the last time - I believe, in replying to Mme Aulagnier, if I remember correctly - as the exclusion determined by the very dependence of the subject on the usage of the signifier. That is why it is in so far as the signifier has to redouble its effect by wanting to designate itself that the subject arises as exclusion from the very field that it determines, being then neither the one who is designated, nor the one who designates, but more or less the following, which is the essential point that this is only produced in relation to the operation of an object at first as alternation between a presence and an absence. What is first of all formally meant by the conjunction \$ and small o is that in the phantasy, the

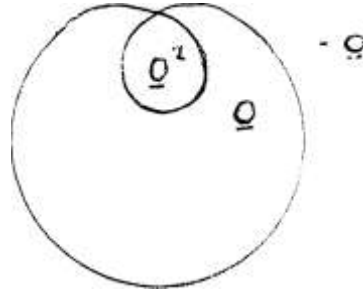

subject in his purely formal aspect and radically, becomes $(-o)$, the absence of o , and nothing but that in front of the small o at the level if you wish of what I called identification to the unary trait, identification is only introduced, only operates purely and simply in this product of $-o$ by the small o , and that it is not difficult to see how, not simply as it were by a mental operation, but because we are brought back to it by something which is, for us, our mode of something which there legitimately receives its formula, the $(-o^2-) = 1$ which results from it introduces us to what is carnal, implied in this mathematical symbol of the root of $0-1$: $\sqrt{-1}$

Of course, we would not dwell on such an operation if we were not brought back to it from more than one angle in a converging fashion.

For the moment, let us set out again to try to designate what determines for us in the drawing of the structure, the necessity of giving an account of the shape to which desire leads us. Let us not forget that unconscious desire, as we have to account for it, is found in the repetition of demand; and after all, from the origin of what Freud modulates for us, it is what motivates it. I see someone saying to me: "Yes indeed, of course that is never spoken about" except that for us desire is not justified simply by being a tendency, it is something else. If you understand, if you follow what I intend to signify for you by desire, it is that we do not content ourselves with an opaque reference to an automatism of repetition, in so far as we have perfectly identified this automatism of repetition: it is a matter of the (8) search, which is at once necessary and condemned, for one unique time, qualified, pinpointed as such by this unary trait, the very one which cannot repeat itself, except always by being another one.

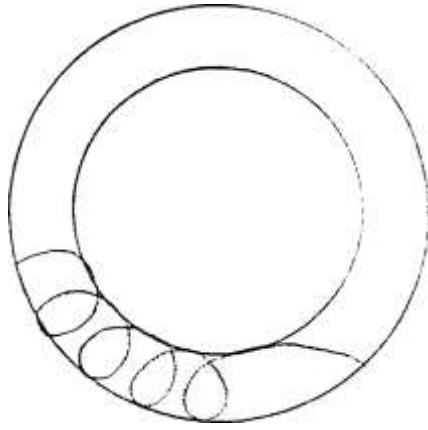

And from then on, in this movement, this dimension appears to us through which desire is what supports the no doubt circular movement of the always repeated demand, but of which a certain number of repetitions can be conceived - this is the use of the topology of the torus - as achieving something. The bobbing movement of the repetition of demand closes somewhere even virtually, defining another loop which is completed by this very repetition and which sketches out what? The object of desire, which it is necessary for us to formulate in this way in so far as equally at the start what we are setting up as the very basis of our whole apprehension of analytic signification is essentially the fact that no doubt we speak about oral, anal objects etc. but that this object has an import for us: this object structures what for us is fundamental in the relationship of the subject to the world by something that we always forget: it is that this object does not remain an object of need; it is from the fact of being caught up in the repetitive movement of demand, in the automatism of repetition, that they become object of desire.

This is what I wanted to show you the day when for example taking the breast as signifier of the oral demand, I showed you that precisely it is because of this that eventually - this was the simplest thing I had to make you put your finger on it - it is precisely at that moment that the real breast becomes not an feeding object, but an erotic object, showing us once again that the function of the signifier excludes the signifier being able to signify itself. It is precisely because the object becomes recognisable as signifier of a latent demand that it takes on the value of a desire which is of another register.

The libidinal dimension, which began to be entered into in analysis as marking all human desire, only means, can only mean that. This does not mean that it is not necessary to recall it. It is the factor of transmutation that it is a matter of grasping, the factor of this transmutation is the function of the phallus, and there is no way of defining otherwise the function of the phallus, small phi, this is what we are going to try to give its topological support.

(9) The true shape of the phallus, which is not necessarily that of a tail, even though it is very like one, is something that I do not despair of drawing for you on the blackboard; if you were able, without succumbing to vertigo, to contemplate with some persistence the aforesaid tail of which I am speaking, you would be able to perceive that with its foreskin it is really

constructed in a funny way. This will help you perhaps to realise that topology is not just the scrap of paper thing that you imagine as you will certainly have occasion to take into account.

This having been said, it is not for nothing no doubt that throughout the centuries of the history of art there are only really such lamentably gross representations of what I am calling the tail.

Still let us begin by recalling this all the same because one should not go too quickly: it is never so much there, this phallus - it is from this one must begin - as when it is absent, which is already a good sign for presuming that it is the pivot, the turning point of the constitution of every object of desire. It would be tiresome for me to have to recall more than one indication of the fact that it is never so much there than when it is absent, let it be enough for me to evoke the equivalence of girl=phallus to say everything that the omnipresent silhouette of Lolita may make you sense. I do not need Lolita all that much; there are people who know very well simply how to sense what the appearance of a bud on a little branch of a tree is. It is obviously not the phallus - because after all the phallus is the phallus - it is all the same its presence precisely where it is not. This even goes very far. Mme Simone de Beauvoir wrote a whole book in order to recognise Lolita in Brigitte Bardot. The distance there is between the complete development of feminine charm and what is properly speaking the mainspring, the erotic activity of Lolita seems to me to constitute a total gap, the easiest thing in the world to distinguish.

When did we begin here to concern ourselves with the phallus in a fashion which is a little structuring and fruitful? It was obviously in connection with problems of feminine sexuality, and the first introduction of the difference in structure between demand and desire, do not forget, was about facts discovered in all their original relief by Freud when he tackled this subject, namely when he articulated in a fashion that is very close to this formula that it is because the phallus has to be demanded where it was not, namely in the mother, from the mother, through the mother, for the mother that it is along there that there passes the normal path through which it can come to be desired by (10) the woman.

If it is a fact that it happens that it can be constituted as an object of desire for her, analytic experience puts the accent on the fact that it is necessary that the process should pass by way of a primitive demand, with everything that it involves on this occasion of the absolutely phantastical, unreal, unnatural, a demand structured as such and a demand which continues to carry its marks to the point that it appears inexhaustible and that the whole accent of what Freud said does not mean that it is enough for Mr Joyce [Jones?] himself to understand it. That means that it is in the measure that the phallus can continue to remain indefinitely an object of demand to the one who cannot give it on this plane, that there arises precisely the whole difficulty in

that it even reaches what might even seem - if really God made them man and woman, as the atheist Jones says: in order that they should be for one another like a thread is for a needle - what would seem nevertheless to be natural: that the phallus was at first object of desire.

This is the way in, the difficult way in, and the way in which twists the whole relationship that this phallus brings with it at a point where it seems to be the most natural object, in the function of object.

The topological schema that I am going to shape for you and which consists with respect to what first of all is presented for you in the shape of the inverted eight, is designed to warn you about

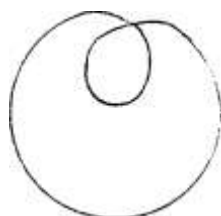

the problematic of any limiting usage of the signifier, in so far as by it a limited field cannot be identified to the pure and simple one of a circle. The field marked inside is not as simple as the one here, as the one which a certain outside signifier marked. There is necessarily produced somewhere, from the fact that the signifier redoubles itself, is summoned to the function of signifying itself, a field which is one of exclusion and through which the subject is rejected into the outside field. I anticipate and I propose that the phallus in its radical function is simply signifier, but even though it can signify itself, it is unnameable as such. If it is in the order of the signifier - because it is a signifier and nothing else - it can be posed (11) without being different to itself. How can it be conceived intuitively? Let us say that it is the only name which abolishes all other nominations and that it is for that reason that it is unsayable. It is not unsayable because we call it the phallus but one cannot at the same time say the phallus and continue to name other things.

The final reference point: in our indications at the beginning of one of our scientific years someone tried to articulate in a certain fashion the most radical transferential function occupied by the analyst as such. It is certainly an approach which is not at all to be neglected that he managed to articulate quite crudely; and indeed what can it mean that one might feel that it is rather brazen for the analyst in his function to have the place of the phallus?

The fact is that the phallus of the Other is very precisely what incarnates, not the desirable, the eromenos, even though its function is that of the postman through whom any object whatsoever may be introduced to the function of object of desire, but that of desirer, of the eron. It is in so far as the analyst is the presence which supports an entirely veiled desire that he

is the incarnated "Che vuoi?"

I will recall later that one can say that the $\hat{}$ factor of the phallic value constitutive of the very object of desire is supported and incarnated by him. But it is a function of subjectivity so redoubtable, so problematic, so projected into such a radical otherness, and it is indeed for that reason that I led you and brought you to this crossroads last year as being the essential mainspring of the whole question of transference: what should this desire of the analyst be?

For the moment what is proposed to us, is to find a topological model, a transcendental aesthetic model which would allow us to account at once for all these functions of the phallus. Is there something which resembles that, which like that is what one calls in topology a closed surface, a notion which takes on its

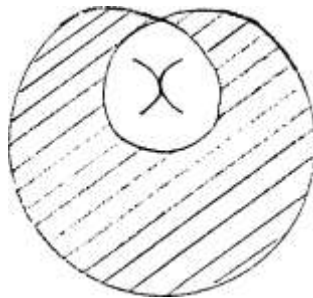

function, to which we have the right to give a homologous value, an equivalent value to the function of significance because we can define it by the function of the cut. I already referred to it on several occasions. The cut, I mean with a pair of scissors, a rubber ball, in order to prevent through habits that one could qualify as age-old in many cases a crowd of problems that are posed from immediately striking us.

When I thought I was telling you very simple things in connection with the interior eight on the surface of the torus, and when subsequently I unrolled my torus believing that it was self-evident, that I had a long time ago explained to you that there was a way of opening the torus by cutting it with a scissors and when you open the torus crossways you have an open belt, the torus is reduced to that (see the schema) and it is enough at that moment to try to project onto this surface the rectangle which we would have done better to call the quadrilateral, to apply onto it what we have designated previously in this form of the inverted eight in order to see what happens and to what something is effectively limited, something can be chosen, distinguished between a field limited by this cut and, if you wish, what is outside, something which is not so obvious, does not immediately strike us.

Nevertheless, this little image that I represented for you seems in the first shock to have created problems for certain people. It must be therefore that it is not so easy.

The next time I will not only have to return to it, but to show you something which I have no reason to make a mystery of beforehand, because after all if some of you want to prepare yourselves for it, I am indicating to them that I will speak about another type of surface defined as such and purely in terms of surface, whose name I already pronounced and which will be very useful for us. This is called in English, where the works are the most numerous, a cross-cap, something which means something like a bonnet croise. It has been translated into French on certain occasions by the term mitre, with which effectively it may have a rough resemblance.

This form of topologically defined surface involves in itself certainly a purely speculative and mental attraction which, I hope will not be lost on you. I will take care to give you figurative representations of it which I have done in great quantity, and especially from the angles which are not the ones of course from which it interests mathematicians or in which you will find them represented in some works about topology. My (13) figures will preserve all their original function, while accepting that I do not give them the same usage and that it is not the same things that I was looking for.

You should know however that what it is a matter of forming in a tangible, sensitive fashion, is designed to involve as a support a certain number of reflections and others which are subsequently expected, your own on this occasion, to involve what I might call a mutative value, which will allow you to think out the logical things with which I began in a different fashion which does not keep them moored for you to the famous Eulerian circles.

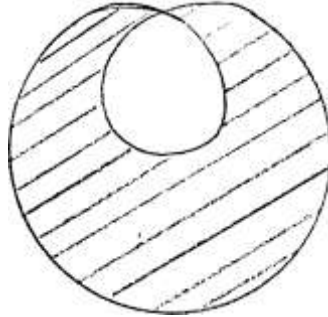

Far from this interior field of the eight being obligatorily and forever an excluded field, at least in a topological shape, a very tangible fact and one of the most representable and the most amusing of cross-caps in question, in so far as far from this field being a field to exclude, it is on the contrary to be completely kept.

Of course we should not allow this to go to our heads. There would be a quite simple way of imagining it in a way that should be held onto. It is not very difficult. You only have to take something which has a more or less appropriate shape: a slack circle and, twisting it in a certain fashion and folding it, to have in front a little tongue whose bottom would be in continuity with the rest of the edges. Only there is all the same the following: namely that this is never anything but an artifice,

namely that this edge is effectively always the same edge.

This indeed is what is in question: it is a question of knowing very differently whether this surface makes a case for us which finds itself intuitively, aesthetically symbolised. Another possible import of the signifying limit of the field marked out is realisable in a way that is different and in a way immediately obtainable through the simple application of the properties of a surface which you are not used to up to the present. This is what we will see the next time.

Seminar 20: Wednesday 16 May 1962

(Edited from notes)

I am justifying the necessity of these lucubrations about the surface. It is obvious that what I am telling you about it is the result of a reflection. You have not forgotten that the notion of surface in topology is not a self-evident one and it is not given as an intuition. The surface is not something self-evident.

How can it be tackled? Starting from what introduces it into the real, namely what would show that space is not this open and contemptible extension that Bergson thought it was, space is not as empty as he thought, it conceals many mysteries.

Let us pose certain terms at the beginning.

It is certain that a first essential thing in the notion of surface is that of face: there are two faces or two sides in it. This is obvious if we plunge this surface into space. But to appropriate to ourselves what the notion of surface can take on for us, it is necessary that we should know what it presents us with from its dimensions alone, indeed what it can give us qua surface dividing space by its dimensions alone, suggests to us that we should reconstruct space in a different way to the intuition we believe we have of it. In other words, I propose to you to consider it as more obvious (imaginary capture), much more certain (linked to action), more structural to start from the surface to define space - which I hold we have few guarantees about - let us say rather to define the locus (lieu), than to start from the locus to define the surface - cf the locus in philosophy. The locus of the Other already has its place in our seminar. To define the face of a surface, it is not enough to say that it is on one side and on the other, all the more so because that has nothing satisfying about it, and if something (2) gives us a Pascalian vertigo, it is indeed these two regions into which an infinite plane is supposed to divide the whole of space.

How define this notion of face? It is the field on which a line, a path can be extended without having to meet an edge. But there are surfaces without edges: the plane to infinity, the sphere, the torus and several others which are surfaces without edge being reduced practically to a single one: the cross-cap or mitre or bonnet pictured here (1).

In learned books this is what the cross-cap is: cut in order to

be inserted onto another surface (2).

These three surfaces, sphere, torus, cross-cap are elementary closed surfaces to the composition of which all the other closed surfaces can be reduced.

I will nevertheless call figure 1 the cross-cap. Its real name is the projective plane of Riemann's theory of surfaces whose plane is the base. It brings into play at least the fourth dimension.

Already, for us depth psychologists, the

third dimension creates problem enough for us to consider it as not very assured. Nevertheless in this simple figure, the cross-cap, the fourth is already necessarily implied.

The elementary knot made the other day with a piece of string already presentifies the fourth dimension. There is no valid topological theory unless we make intervene something which will lead us to the fourth dimension.

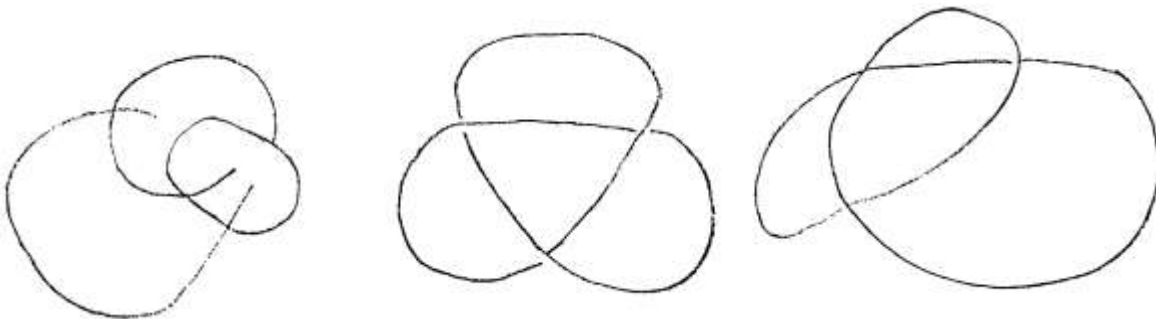

(3) If you want to try to reproduce this knot using the torus by following the circuits and the detours that you can make on the surface of a torus, you could after several circuits return to a line which closes on itself like the knot above. You cannot do it unless the line cuts itself; since [on] the surface of the torus you will not be able to mark that the line passes above or below, there is no means of making this knot on the torus. It is on the contrary perfectly makeable on the cross-cap. If this surface implies the presence of the fourth dimension, it is a beginning of the proofs that the most simple knot implies the fourth dimension. I am going to tell you how you can imagine this surface, the cross-cap. It will not impose its necessity by that even, for us, its manoeuvre. It is not unrelated to the torus, it even has the most profound relationship to the torus. The simplest fashion to show you this relationship is to recall to you how a torus is constructed when it is decomposed in a polyhedric shape, namely by bringing it back to its fundamental polygon. Here this fundamental polygon, is a quadrilateral. If you fold this quadrilateral onto itself, you will get a tube by



joining the edges. If you vectorize these edges by agreeing that only the vectors which go in the same direction can be stuck to one another, the beginning of one vector being applied to the point where the other vector terminates, from then on you have all the coordinates for defining the structure of the torus.

If you make a surface whose fundamental

polygon is thus defined by vectors all going in the same direction on the basic quadrilateral, if you start from a polygon defined in this way, that will give you two edges or even a single one, you get what I am materializing for you as the cross-cap.

I will come back to its function of symbolising something and it will be clearer when this name serves as a support.

In section with its jawbone, it is not what you think, this is a line of penetration thanks to which what is in front...

Why this shape more than any other? Its fundamental polygon is

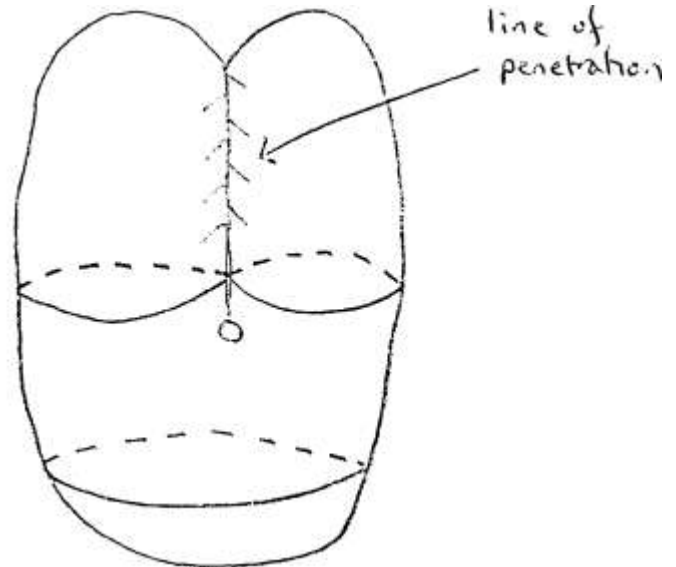
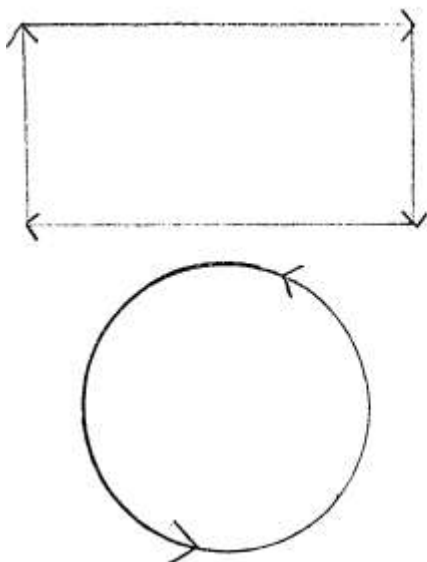

(4) Underneath is a half sphere, above the front wall passes by penetration into the opposite wall and comes back in front.

distinct from that of the torus. A polygon, whose edges are marked by vectors in the same direction, and distinct from that of the torus, which starts from one point to go to the opposite point, what sort of surface does that give?

From now on the problematic points of these surfaces become separated out. I introduced you to surfaces without edges in connection with the face. If there is no edge how can you

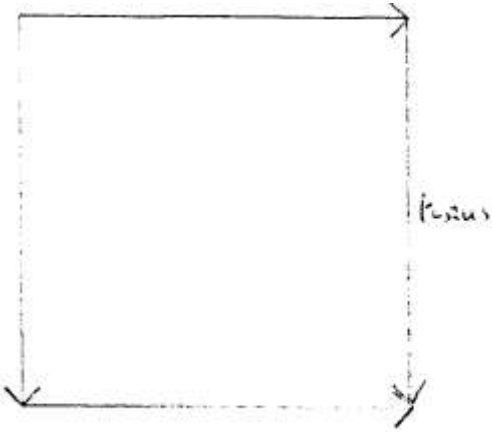

define the face? And if we prohibit ourselves as far as possible from plunging our model too quickly into the third dimension, where there is no edge we will be assured that there is an inside and an outside. This is what is suggested by this surface without edges par excellence which is the sphere. I want to detach you from this vague intuition: there is what is within and what is without.

Nevertheless for the other surfaces, this notion of inside and outside disappears. For the infinite plane, it would not suffice. For the torus, intuition apparently fits sufficiently because there is an inside of a bicycle tube and an outside. Nevertheless what happens in the field through which this outside space traverses the torus, namely the central hole, is the (5) topological kernel of what gave its interest to the torus and where the relationship of inside to outside is illustrated by something which may touch us.

Notice that up to Freud, traditional anatomy, ever so little a Wissenschaft in the case of Paracelsus and Aristotle, always took account, among the orifices of the body, of the sense organs as authentic orifices.

Analytic theory, in so far as it is structured by the function of the libido, made a very narrow choice among the orifices and does not speak to us about sensory orifices as orifices, except to refer them back to the signifier of the orifices first chosen. When one makes of scotophilia a scotophagia, as Fenichel does, one is saying that scotophilic identification is an oral identification.

The privilege of the oral, anal and genital orifices is of interest to us in that they are not really orifices which end up on the inside of the body: the digestive tube is only a passage, it is open to the outside. The true inside is the mesodermic interior and the orifices which lead into it exist in the form of the eyes or of the ear which analytic theory never mentions as such except on the cover of the review La Psychanalyse. This is the real import given to the central hole of the torus; even

though it is not a real inside, but that it suggests to us something of the order of a passage from the inside to the outside.

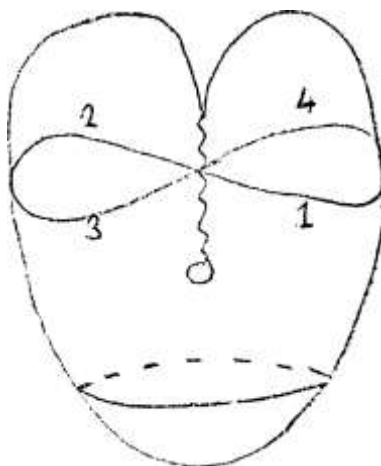

This gives us an idea which comes from inspecting this closed surface, the cross-cap. Imagine something infinitely flat which moves about on this surface passing from the outside 1 of the closed surface to the inside 2 and continues further to the inside 3

of the line of penetration where it re-emerges at the outside 4
(at the back).

This shows the difficulty of defining the inside-outside distinction, even when a closed surface, a surface without edges is involved. I have only opened up the question in order to show you that the important thing in this figure is that this line of penetration should be held by you to be null and void. One cannot materialize it on the blackboard without bringing this line of penetration into play, because ordinary spatial intuition requires it to be shown, but speculation takes no account of it. One can make this line of penetration slide indefinitely. There is nothing of the order of a seam. There is no passage possible. Because of this, the problem of the inside and the outside arises in all its confusion.

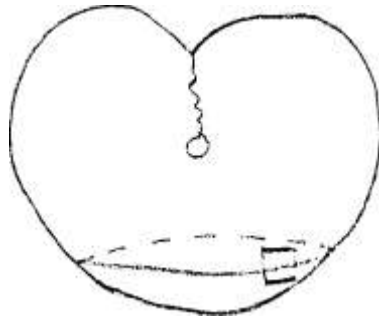

There are two orders of consideration as regards a surface: metrical and topological. All metrical considerations must be put aside: in effect starting from this square, I could give the whole surface. From a topological point of view, that has no meaning. Topologically the nature of the structural relationships which constitute the surface is present at every point: the inside face is merged with the outside face for each one of its points and its properties.

To mark the interest of this, we are going to evoke a question never yet posed which concerns the signifier: does a signifier not always have a surface as a locus? This may appear a bizarre question. But it has at least the interest, if it is posed, of suggesting a dimension. At first approach a graph (graphique) as such requires a surface. If it is a fact that the objection can be raised that a raised stone, a Greek column is a signifier and that it has a volume, do not be so sure of it, so sure of being able to introduce the notion of volume before being well assured about the notion of surface. Especially if, in putting things to the test, the notion of volume cannot be grasped otherwise than starting from what envelopes it. No raised stone has interested us for anything else, I would not say but for its envelope - this would be going towards a sophism - but for what it envelopes.

Before being about volumes, architecture came about by mobilising, by arranging surfaces around a void. Raised stones (7) are used to make alignments or tables, to make something which is of use because of the hole around it.

Because this is the remainder that we have to deal with. If, in grasping the nature of face, I started from a surface with edges in order to point out to you that the criterion failed us in surfaces without edges, if it is possible to show you a fundamental surface without edges, where the definition of the face is not necessary, because the surface without edges is not suitable for resolving the problem of inside and outside, we ought to take into account the distinction between a surface without and a surface with: it has the closest possible relationship with what interests us, namely the hole which is to be made enter positively as such into the theory of surfaces.

This is not a verbal artifice. In the combinatory theory of general topology, every triangulatable surface, namely one composable of little triangular pieces that you could stick onto one another, torus or cross-cap, can be reduced by means of the fundamental polygon to a composition of the sphere to which there would be added more or less toric elements, cross-cap elements and the indispensable elements of pure holes represented by this vector looping back on itself.



Cannot a signifier, in its most radical essence, be envisaged simply as a cut $> <$ in a surface, these two signs "greater: $>$ " and "smaller: $<$ " only impose themselves by their cut-structure inscribed on something where there is always marked, not simply the continuity of a plane on which what follows will be inscribed, but also the vectorial direction where this will always be rediscovered? Why has the signifier in its corporal that is to say vocal incarnation always been presented to us as essentially discontinuous? We had therefore no need of surface: discontinuity constitutes it. The interruption in the successive forms part of its structure.

This temporal dimension of the functioning of the signifying chain which I at first articulated as succession, has as a consequence that the scansion introduces an additional element than the division of the modulatory interruption: it introduces (8) haste which I inserted qua haste in logic. It is an old work: "Le temps logique".

The step that I am trying to get you to take has already begun to be traced, it is the one in which discontinuity is bound to what is the essence of the signifier, namely difference. If that on which we have made pivot, have ceaselessly brought back this function of the signifier, is to draw your attention to the fact that, even by repeating the same, the same by being repeated is

inscribed as distinct. Where is the interpolation of a difference? Does it reside only in the cut - it is here that the introduction of the topological dimension beyond the temporal scansion interests us - or in something else which we will call the simple possibility of being different, the existence of the differential battery which constitutes the signifier and through which we cannot confuse synchrony with simultaneity at the root of the phenomenon, synchrony which makes the same reappear?

It is as distinct from what it repeats that the signifier reappears, and what can be considered as distinguishable is the interpolation of difference in so far as we can pose the identity of "a and a" as fundamental in the signifying function, namely that difference is in the cut, or in the synchronic possibility which constitutes the signifying difference. In any case, what we repeat is only different because it can be inscribed.

It remains nonetheless that the function of the cut is of the greatest importance for us in what can be written. And it is here that the notion of the topological surface ought to be introduced into our mental functioning because it is only here that the function of the cut takes its interest.

Inscription bringing us back to memory is an objection to be refuted. The memory which interests us analysts, is to be distinguished from an organic memory, the one which would respond to the same suction of the real in the same way for the organism to defend itself from it, as well as the one which maintains homeostasis, because the organism does not recognise the same which is renewed qua different. Organic memory memorises (meme-orise).

(9) Our memory is something different: it intervenes in function of the unary trait marking the unique time and has as a support inscription. Between the stimulus and the response, the inscription, the printing, ought to be recalled in terms of Gutenberg's printing press. The first rough outline of psychophysical theory against which we rebel is always atomist; it is always in the imprinting of surface schemas that this psychophysics takes its first foundation. It is not enough to say that it is insufficient before one has found something different.

Because if it is of great interest to see that the first theory of relational life is inscribed in interesting terms which express only without knowing it the very structure of the signifier under the masked forms of distinct effects of contiguity and continuity (associationism) it is good to show what was recognised and miscognised as signifying dimension was the effects of the signifier in the structure of the idealist world from which this psychophysics never detached itself.

Inversely what was introduced by the Gestalt is not enough to account for what happens at the level of vital phenomena, because of a fundamental ignorance which is expressed by the rapidity with which one holds as certain coordinates which everything

contradicts. The so-called good form of the circumference that the organism is supposed to strive on every plane - subjective or objective - to try to reproduce is contrary to every observation of organic forms. I would say to the Gestaltists that a donkey's ear resembles a cornet, an arum, an Mobius surface. A Mobius surface is the most simple illustration of the cross-cap: it is constructed with a strip of paper, the two ends of which one sticks together after having twisted it, so that the infinitely flat being which goes along it can follow it without ever crossing an edge. This shows the ambiguity of the notion of face. Because it is not enough to say that it is a unilateral surface, with a single face, as certain mathematicians formulate it. A formal definition is a different thing, it nevertheless remains that there is a coalescence for each point of the two faces and this is what interests us. For us who are not satisfied to say unilateral under the pretext that these two faces are always present, it nevertheless remains that we can manifest at every point the scandal for our intuition of this relationship of the two faces.

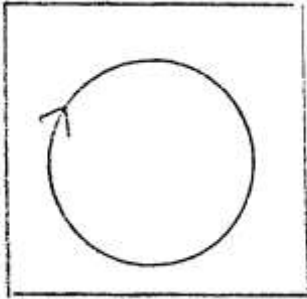

(10) If in effect on a plane we trace a circle in a clockwork direction, from the other side, by transparency, the same arrow turns in the opposite direction. The infinitely flat being, the little personage on the Mobius surface, if he carries with him a circle turning around him in the clockwise direction, this circle will turn

always in the same direction, so that from the other side of its point of departure what will be inscribed will turn in the horary direction, namely in a sense opposite to what would happen on a normal strip on the plane: it is not inverted.

This is why these surfaces are defined as non-orientable and nevertheless are no less oriented. Even though desire is not articulatable we cannot say for all that that it is not articulated. Because these

little ears in the Mobius strip, however non-orientable they may be, are more oriented than a normal strip. Make a conical belt for yourself.

Turn it over: what was open below is now so on top. But turn over the Mobius strip: it will always have the same

shape. Even when you turn over the object, it will always have the sunken hump on the left, the swollen hump on the right: a non-orientable surface is therefore much more oriented than an orientable surface.

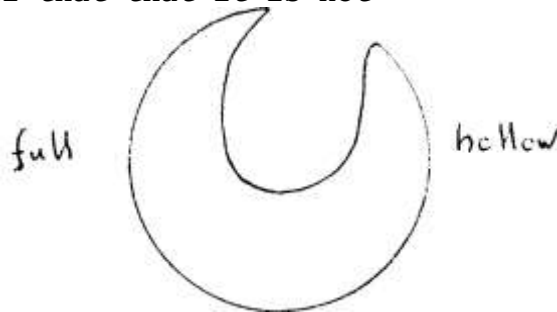

Something which goes still further and surprises the mathematicians who with a smile refer the reader to experience, is that, if in this Mobius strip using a scissors you make a cut

at an equal distance from the most accessible points of the edges (it has only a single edge), if you make a circle, the cut closes on itself, you produce a circle, a loop, a closed Jordan curve. Now this cut, not alone leaves the surface entire, but transforms the non-orientable surface into an orientable surface, namely into a strip which, if you colour one of the sides, a whole side will remain blank, contrary to what would have happened earlier on the entire Mobius surface: everything would have been coloured without the paintbrush changing face. The simple intervention of cut has changed the omnipresent structure of all the points of the surface, as I told you. And if I ask you to tell me the difference between the object before the cut and this one, there is no way of doing it, this to introduce the interest of the function of the cut.

The quadrilateral polygon originates the torus and the cross-cap. If I never introduced the true verbalisation of this shape o , stamp, desire, uniting the \$ to the o in the \$ $\blacktriangleleft o$, this little quadrilateral should be read: the subject qua marked by the signifier is properly in the phantasy, the cut of o .

Next time, you will see how this will give you a functioning support to articulate the question: how what we can define, isolate starting from demand as field of desire, in its ungraspable aspect, can, by some torsion or other, knot itself to what taken from another angle is defined as the field of the object o , how can desire be equal to o . This is what I introduced and what will give you a model useful even in your practice.

Seminar 21: Wednesday 23 May 1962

Why is a signifier grasped by (saisi de) the slightest thing? Can it grasp the slightest thing? Here is the question, a question which perhaps it is not excessive to say has not yet been posed because of the form that logic classically took on. In effect the principle of predication which the universal proposition implies only one thing: that what one grasps are nullifiable beings: the dictum of omni et nullo. For those for whom these terms are not familiar and who consequently do not understand very well, I recall that this is what I have been in the process of explaining to you for a number of occasions now, namely taking the support of the Eulerian circle all the more legitimately in that what it is a question of substituting is something different, the Eulerian circle like what I might call any naive circle, the circle in connection with which the question does not arise of knowing whether it rings a fragment, a piece. The proper of the circle, whether or not it detaches a piece of this implied hypothetical surface, is that it can be progressively reduced to nothing. The possibility of the universal, is nullity. All professors, I told you one day - because I chose this example in order not to fall always into the same problems - all professors are literate; well then, if by chance somewhere no professor merits to be qualified as literate, this does not mean that we will have professors who are nuls. Notice carefully that this is not the same thing as saying that there are no professors. The proof is that we do have stupid (nuls) professors on occasion. When I say "to have", take this to have in the strong sense, in the sense that is involved. It is not a slippery word that lets the soap fall. When I say "we have them", that means that we are used to having them. In the same way we have a load of things like that: we have the republic, as the countryman with whom I spoke not long ago said: this year, we had hail, and then afterwards the boy scouts. (2) Whatever may be the definitional precariousness for the countryman of these meteors, the verb "to have" has therefore here indeed its meaning.

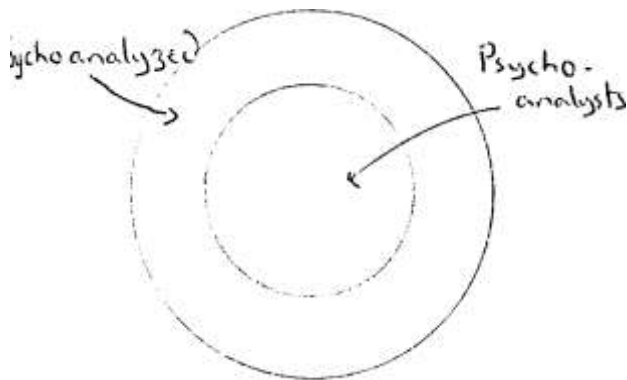

We also have for example psychoanalysts; and it is obviously much more complicated because psychoanalysts begin to make us enter into the order of existential definition. We enter into it by way of the condition. We say for example: there is not, no one can

call himself a psychoanalyst if he has not been psychoanalysed. Well now, there is a great danger of believing that this relationship is homogeneous with what we evoked previously in the sense that, to make use of the Eulerian circles, there would be the circle of those psychoanalysed; but, as everyone knows, all psychoanalysts having to be psychoanalysed, the circle of psychoanalysts could therefore be traced as included in the circle of the psychoanalysed. I do not need to say that if our experience with psychoanalysts was not able to be analysed, it is probably because things are not so simple, namely that after all if it is not obvious at the level of the professor that the very fact of functioning as professor can draw into the professor's breast, like a siphon, something which empties him of all contact with the effects of the letter, it is on the contrary quite obvious for the psychoanalyst that this is the whole problem. It is not enough to refer the question on to: what does being psychoanalysed mean? Because of course what one believes one is doing there, and of course naturally, would divert nobody from putting in the forefront the question of what it is to be psychoanalysed. But in the relationship to the psychoanalyst, this is not what must be grasped, if we wish to lay hold of the conception of the psychoanalyst: it is to know what it means to the psychoanalyst to be psychoanalysed, this qua psychoanalyst and not as part of the psychoanalysed. I do not know whether I am making myself understood, but I am going to bring you back once again to the abc, to elementary things. If all the same in listening to the oldest example in logic, the first step that was made to push Socrates into a hole, namely: "all men are mortal", ever since then we have been deafened with this formula, I do not know whether you have had the time to become hardened to it, but for anyone who is a little fresh, the very fact of promoting this example at the heart of logic cannot but be the source of some unease, of some feeling of fraudulence. Because what interest (3) has such a formula for us, if it is man that we are trying to grasp? Unless what is involved - and it is precisely what the concentric circles of Eulerian inclusion dodge - is not to know that there is a circle of mortals and

inside it the circle of man, which has strictly no interest, it is to know how the fact that he is mortal concerns man, to catch hold of the whirlwind which is produced somewhere at the centre of the notion of man because of the fact of his conjunction to the predicate mortal, and that this indeed is why we are chasing after something; when we speak about man, it is precisely about this whirlwind, this hole which is made there in the middle somewhere that we touch.

Recently, I opened an excellent book by an American author whose work one can say augments the patrimony of thinking and of logical elucidation. I am not going to mention his name because you are going to try to find out who it is. And why do I not do

it? Because I, for my part, had the surprise of finding in the pages where he works over so well such a lively sense of the actuality of the progress of logic, where precisely my interior eight intervenes.

He does not make the same use of it at all as I do. Nevertheless I was led to the thought that some mandarins among my listeners would come to tell me one day that it was there that I found it. As regards the originality of the passage I rely in effect on M Jakobson for my strongest reference. I have to say that in this case I believe I began to push forward metaphor and metonymy in our theory sometime around the discourse of Rome which has been published - it was in speaking with Jakobson that he said to me: "Of course, this business of metaphor and metonymy, we worked that out together, you remember, on July 14 1950". As for the logician in question, he has been dead for a long time, and his little interior eight incontestably precedes its promotion here. But when he enters boldly into his examination of the universal affirmative, he makes use of an example which has the merit of not being found everywhere. He says: "All saints are men, all men are passionate, therefore all saints are passionate." He gathers this together because you should clearly sense, in such an example, that the problem is indeed that of knowing where is this most exterior predicative passion, from this universal syllogism to know what sort of passion is appropriate to a heart in order to produce sanctity.

(4) I thought this morning about all that, I mean to say it to you like that in order to make you sense what is involved as regards what I called a certain whirlwind movement. What are we trying to get close to in our apparatus concerning surfaces, surfaces in the sense that we intend giving them here a usage which, to reassure my listeners, uneasy perhaps about my not altogether classical excursions, is all the same something which is nothing other than to renew, to re-interrogate the Kantian function of the schema. I think that the radical illogicality in experience involved in the inclusion of the relationship of extension to understanding, to Euler's circles - this whole direction was begun with "Le temps logique" - is it not in its very deviations the recalling of what was, at its beginning, forgotten, what was at the beginning the object involved - even if it were the purest one: is it or will it be, whatever one does, the object of desire - and that if it is a matter of circumscribing it in order to lay hold of it logically, namely with language, it is because first of all it is a matter of grasping it as object of our desire, having grasped it to keep it, which means to enclose it and that this return of inclusion to the forefront of logical formation, finds its root in this need to possess in which there is grounded our relationship to the object as such of desire.

Begriff evokes grasping because it is from running after the grasp of an object of our desire that we have formed the Begriff. And everyone knows that everything that we want to possess for desire, and not for the satisfaction of a need, flees us and slips away from us. What moral preaching does not evoke it! At

the end we possess nothing! All this must be left behind, said the celebrated cardinal, how sad it is! We possess nothing, says moralistic preaching, because there is death.

What is promised us at the level of the fact of real death is not what is in question; it is not for nothing that for one long year I made you travel in this space that my listeners described as between-two-deaths. The suppression of real death would settle nothing in this affair of the flight of the object of desire because it was the other death that was involved, the one which brings it about that even if we were not mortal, even if we had the promise of eternal life, the question still remains open whether this "eternal life", I mean from which there would be excluded any promise of an end, is not conceivable as a form of eternally dying.

It undoubtedly is, because it is our day-to-day condition, and we (5) should take it into account in our logic as analysts because this is the way it is, if psychoanalysis has a meaning and if Freud was not mad. Because this is what designates this point called the death instinct.

Already the physiologist who was the greatest genius, one might say, of all those who have the sense of this angle of the biological approach, Bichat, said: "Life is the totality of the forces which resist death." If something of our experience can be reflected, may one day take on a stable meaning in this very difficult plane, it is this precession produced by Freud of this formula of the whirlwind of death to the flanks of which life clings in order to avoid falling into it. Because the only thing to be added to render this function quite clear to anyone, is that it is enough not to confuse death with the inanimate, when in inanimate nature it is enough to bend down in order to pick up the trace of what is a dead form, a fossil, in order to grasp that the presence of death in nature is something other than the inanimate.

Is it so sure that these shells and rubbish are a life-function? This is to resolve the problem a little easily when it is a matter of knowing why life twists itself like that. As we take up again the question of the signifier already tackled by way of the trace, the ironic idea came to me, suddenly emerging from the Platonic dialogues, of thinking that this ever so slightly scandalous imprint that Plato takes note of in thinking of the mark left in the sand of the stadium by the bare backsides of the beloveds, expressions towards which the adoration of their lovers precipitated and which their propriety consisted in effacing, they would have done better to leave it in place. If the lovers had been less clouded by the object of their desire, they would have been capable of taking advantage of it and of seeing in it the outline of this curious line that I am proposing to you today, such is the image of the blindness that every desire from being too lively carries with it.

Let us begin again therefore from our line which must indeed be taken in the shape that it is given to us: closed and

nullifiable, the line of the original zero of the effective history of logic. If we learn in it, already coming back to it, that null is the root of all, at least the experience will not have been made in vain.

This line, for us, we call the cut (la coupure), a line - this is our starting point - that we must hold a priori to be closed. This is the essence of its signifying nature. Nothing can ever (6) prove to us, since it is in the nature of each one of these circuits to ground itself as different, nothing in experience can allow us to ground it as being the same line. It is precisely this that allows us to apprehend the real. It is in the fact that its return being structurally different, always another time, if it resembles it, then there is a suggestion, a probability that the resemblance comes from the real. There is no other way of introducing in a correct fashion the function of the similar (du semblable). But this is only an indication that I am giving you. To go further, I think I repeated to you on several occasions if only not to have to come back to it again, that, all the same in recalling it, I refer you to this work by a precocious genius and like all precocious geniuses one who died too soon, Jean Nicaud, "La geometrie du monde sensible", in which the passage concerning the axiomatic line - perhaps some of you who are genuinely interested in our progress might consult it - shows clearly that it is chimerical to dodge the function of the signifying circle in this analysis of sensible experience, leading the author, despite the incontestable interest of what he puts forward to the paralogism which you will not fail to find in it. At the beginning we take this line whose deceptive proof that the inside of the line was something univocal was first upset for you by the existence of the function of defined topological surfaces, because it is enough that the line should be drawn on a surface defined in a certain fashion, the torus for example for it to be apparent that, while retaining its function of cut, it is not able in any way to fulfill here the same function as on the surface that you will allow me without further ado to call here fundamental, that of the sphere, namely to define a piece as nullifiable for example. For those who come here for the first time, this means a closed line drawn here or again this one which can in no way be reduced to zero, namely that the function of the cut that they introduce into the surface is something which every time gives rise to a problem. I think that what is involved as regards the signifier, is this reciprocal liaison which ensures that if on the one hand, as I made tangible for you the last time in connection with the Mobius surface, this nice distorted little ear of which I gave you a few examples, the median cut with respect to its field transforms it into a different surface which is no longer this Mobius surface. If it is a fact that the Mobius surface is - I have more than one reservation about this - can be said to have only one face, undoubtedly the one which results from the cut had two faces. What is involved for us, taking this angle to interrogate the effects of desire by approaching it through the signifier, is to perceive how the field of the cut, the gap of the cut, by organising itself into a surface gives rise for us to all the (7) different shapes in which there can be ordered the moments of

our experience of desire.

When I tell you that it is starting from the cut that there are organised the shapes of the surface involved for us in our experience, since they are able to bring about the effect of the signifier, I illustrate it - it is not the first time I have illustrated it -: here is the sphere, here is our central cut taken from an inverse angle to that of the Eulerian circle. What interests us, is not the piece

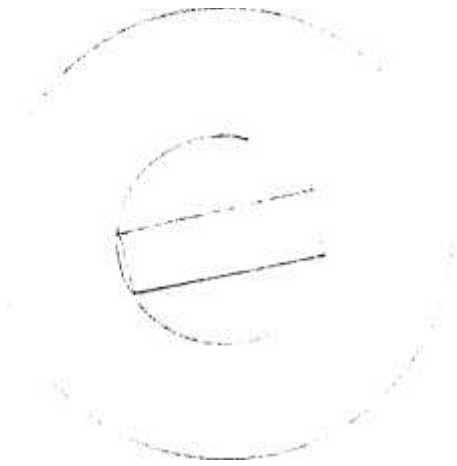

which is necessarily detached on the sphere by the closed line, it is the cut thus produced and, if you wish, already here and now the hole. It is quite clear that everything that we are going to find at the end must already be given, in other words that here already a hole has all its meaning, a meaning made particularly obvious by the fact of our having recourse to the sphere. A hole here makes the inside and the outside communicate with one another. There is only one little piece of bad luck: it is that once the hole is made, there is no longer either an inside or an outside, as is only too obvious from the fact that it is the easiest thing in the world to turn this sphere with a hole in it inside out. We are dealing with the universal, primordial, creation - that of the eternal potter. There is nothing easier than to turn a bowl, that is to say a skullcap. The hole would then not have any great meaning for us, if there were not this other thing to support this fundamental intuition - I think that this is familiar to you today - namely that avatars happen to a hole, a cut, and the first possible one is that two points of the edge are coupled: one of the first possibilities for a hole is that of becoming two holes.

Certain people have said to me: why do you not refer your images to embryology? Believe me they are never very far from it. This is what I am explaining before you, but it would only be an alibi because for me to refer to embryology here is to give myself over to the mysterious power of life which for some unknown reason it really believes can only be introduced into the world from the angle of, through the mediation of this globule, of this sphere which is multiplied, is depressed, is invaginated, is swallowed by itself, then peculiarly at least up to the level of the betrachia, the blastopore, namely this something which is not a hole in the sphere, but a piece of the sphere which has entered into the



(8) other. There are enough doctors here who have done a little bit of elementary embryology to remember this something which begins to divide itself in two to initiate this curious organ that is called the neuroenteric canal which is completely unjustifiable by any function, this communication from the inside of the neural tube to the digestive tube being rather to be

considered as a baroque peculiarity of evolution which moreover is promptly reabsorbed: in subsequent evolution nothing more is said about it.

But perhaps matters would take a new turn if they were taken as a metabolism, a metamorphosis guided by elements of structure whose presence and homogeneity with the plane on which we are moving about in the guise of a signifier are the term of what is a sort of pre-vital isolation of the trace of something which could perhaps lead us to formalisations which even on the plane of the organisation of biological experience might prove fruitful. In any case, it is these two isolated holes at the surface of the sphere, which connected to one another and then very extended then connected, gave us the torus. This is not new. Simply I would like to clearly articulate the result for you; the result



first of all, is that there is something which for us supports the intuition of the torus, it is that: a macaroni which connects up with itself, which bites its own tail this is what is what is most exemplary in the function of the hole. There is one in the middle of macaroni and there is a draught, which means that in passing through the hoop that it forms there is a hole which makes the outside communicate with the inside, and then there

is another

still more formidable one which puts a hole at the heart of the surface which is here a hole while at the same time being completely outside. The image of boring is introduced; because what we are calling hole, is that: it is this corridor drilled into a thickness, a fundamental image which as regards the geometry of the sensible world has never been sufficiently distinguished. And then the other hole which is the central hole of the surface, namely the hole that I would call the hole that causes a draught. What I am claiming to advance to pose our problems, is that this irreducible draught-hole, if we ring it with a cut, is properly where there belongs, in the effects of the signifying function, *o*, the object as such. This means that the object is missed, because in no case could there anything (9) here but the contour of the object, with all the meanings that you can give to the word contour. Another possibility opens out again which for us vivifies, gives its interest to the structuring and structural comparison of these surfaces, it is

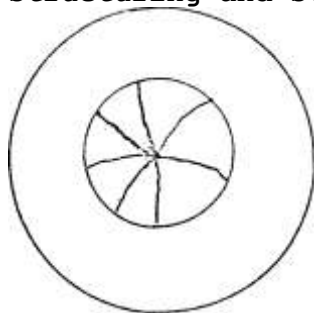

that the cut can be articulated differently on a surface. We can enounce, formulate, wish that each point of the hole drawn here on the surface should be connected to its antipodal point, that without any division of the gap, the gap organises itself into a surface in a way which outlines it completely without the medium of this intermediary division. I showed you the

last time and I will show you again: this can give us the surface described as the bonnet or cross-cap, namely something about which it would be well for you not to forget that the image which

I gave you is only properly speaking a distorted image because what appears to each and everyone who has reflected on it for the first time, what creates an obstacle in it, is the question of this famous line of apparent penetration of the surface through itself which is necessary to represent it in our space. What I am designating here in a wavering line, I am doing to indicate that it must be considered as vacillating, not as fixed. In other words we never have to take into account everything which is paraded here on one side at the outside of the surface, which cannot pass to the outside of the other side because there is no

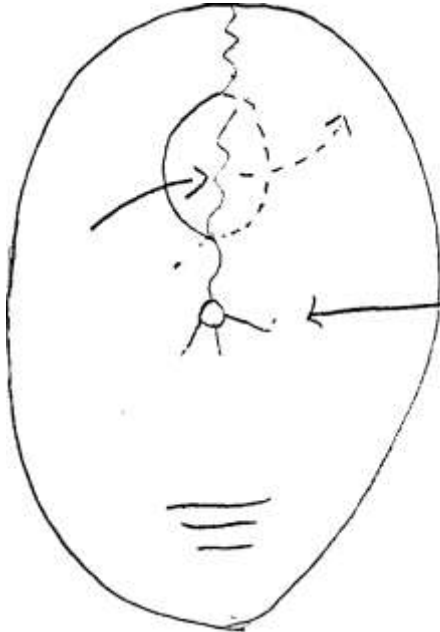

real meeting of faces, but on the contrary could only pass from the other side to the inside therefore of the other face, I mean the other with respect to the observer placed here.

Therefore representing things in this way as regards this shape of surface depends only on a certain incapacity of intuitive shapes of space in three dimensions to allow the support of an image which really takes into account the continuity obtained under the name of this new surface called the cross-cap, the bonnet, in question. In other words what does this surface

sustain? We will call it - since these are theses that I am advancing at first, and we will allow ourselves subsequently to give its meaning to the usage that I will propose to you to make (10) of these different shapes - we call this surface, not the hole - because as you see, there is at least one that it avoids, whose shape completely disappears - but the place of the hole. This surface structured in this way is particularly suitable to make function before us this most ungraspable element which is called desire as such, in other words lack. It remains nevertheless that this surface



impossible

which fills the gap despite the belongingness which makes of all these points which we will call, if you wish, antipodal, equivalent points, they can nevertheless not function in this antipodal equivalence if there are not two privileged points. These are represented here by this little ring about which the perspicacity of one of my listeners has already questioned me: "what in effect are you trying to represent

with this little ring?" Of course it is not in any way something equivalent to the central hole of the torus because everything that, at whatever level you place yourself even from this privileged point, everything that is exchanged between one side and the other of the figure, passes here through this false decussation or crossing point which makes up the structure. Nevertheless what is indicated in this way by this form thus encircled is nothing other than the possibility underneath, if one can express oneself in this way, of this point passing from one outside surface to the other.

It is also the necessity of indicating that a non-privileged circle on this surface, a reducible circle, if you make it slide, if you extract it from its appearance of semi-occultation beyond the limit apparently here of re-crossing and of penetration to make it spread itself out, develop in this way towards the lower half of the figure, and therefore isolate



(11) itself here in a form outside the figure, it must always

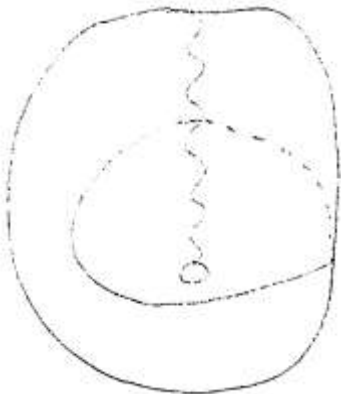

here turn around something which does not allow it in anyway to transform itself into what would be its other shape, the privileged form of a circle in so far as it does the circuit of the privileged point and must then to be depicted on the surface in question: this in effect cannot be equivalent to it in any way, since this shape is something which passes around the privileged point, the structural point around which is supported the

whole structure of the surface thus defined. This double point and single point around which at once there is supported the very possibility of the criss-crossed structure of the bonnet or of the cross-cap, it is by this point that we symbolise what can introduce any object whatsoever to the place of the hole. We know the functions and the nature of this privileged point: it is the phallus; the phallus in so far as it is through it as operator that an object o can be put at the same place where in another structure (the torus) we only grasp its contour. This is

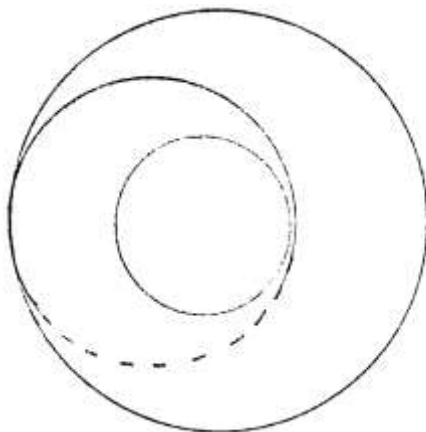

the exemplary value of the structure of the cross-cap that I am trying to articulate before you: the place of the hole, is in (12) principle this point of a special structure in so far as it is a question of distinguishing it from other forms of point, the one for example defined by the overlapping of a cut on itself, the first possible form to be given to our interior eight. We cut something on a sheet of paper for example and a point will be defined by the fact that the cut retraverses a place that is already cut. We know well that this is in no way necessary for the cut to have a completely definable action on the surface and introduce into it this change which it is a matter for us of taking as a support to depict certain effects of the signifier. If we take the torus and cut it in this way, this gives this form that we have drawn here, passing to the other side of the torus, you see clearly that at no moment does this cut rejoin itself. Try the experiment on an old bicycle tube, you will see what that

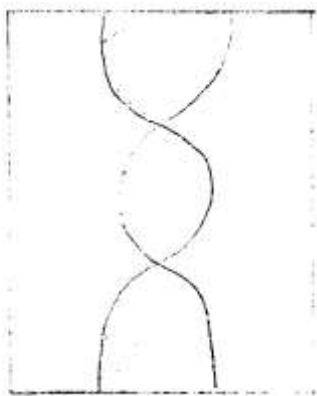

gives: this will give a continuous organised surface of such a kind that it folds back twice on itself before rejoining itself. If it only were folded back once it would be a Mobius surface. Since it folds back twice, it gives a surface with two faces which is not identical to the one that I showed you the other day after the section - the Mobius surface - because that one folds back twice and once again in a different way - a Jordan ring.

The interest for us is to see what exactly this privileged point is in so far as it intervenes as such, specifies the piece where it remains irreducibly, giving to it the particular accent which allows it to designate for us at once the function according to which an object which has always been there, is even before the introduction of the reflections, the appearances that we have in the form of images, the object of desire. It only takes on this effect from the effects of the function of the signifier and one only rediscovers in it its eternal destination as object, it is the only absolutely autonomous, primordial object with respect to the subject, decisive with respect to it to the point that my relationship to this object is in a way to be inverted.

That if in the phantasy the subject through a mirage parallel at every point to the one of the imaginings of the mirror stage, (13) although of a different order, is imagined through the effect of what constitutes it as subject, namely the effect of the signifier, to support the object which comes through it to fill the lack, the hole of the Other - and this is the phantasy - inversely one can say that the whole cut of the subject, that which in the world constitutes it as separate, as rejected, is imposed on it by a determination that is no longer subjective going from the subject towards the object, but objective from the object towards the subject, is imposed on it by the object o, but in so far as at the heart of this object o there is this central point, this whirlwind point through which the object emerges from

a beyond of the imaginary knot, the idealist subject-object which brought about from the beginning of time up to now the impasse in thinking, this central point which from this beyond promotes the object as object of desire. This is what we will pursue the next time.

Seminar 22: Wednesday 30 May 1962

The teaching in which I am leading you is determined by the paths of our experience. It may appear excessive, indeed troublesome, that these paths give rise in my teaching to detours that we might call unusual, and which, because of this, may appear to be really outrageous. I spare you them as much as I can. I mean that, through examples that are tied into, are as close as possible to our experience, I outline a sort of reduction, as one might say of these necessary paths.

You should not however be surprised that there are implicated in our explanation fields, domains such as the one for example this year of topology, if in fact the paths we have to take are those which, putting into question an order as fundamental as the most radical constitution of the subject as such, involve because of this what one could really call a sort of revision of science. For example this radical supposition of ours, which places the subject in his constitution in a dependency, in a secondary position with respect to the signifier, which makes of the subject as such an effect of the signifier, cannot fail to emerge from our experience however incarnated it may be in domains of thinking which are apparently the most abstract. And I do not believe I am forcing anything in saying that what we are elaborating here could be of the greatest interest to a mathematician. For example, as was recently stated, by looking at it closely enough in a theory which, for the mathematician, at one time at least, posed great problems, a theory like that of transfiniteness whose impasses undoubtedly long antedate our highlighting of the function of the unary trait, in so far as what grounds this theory of the transfinite is a return to, a grasp of, the origin of counting before number, I mean of what precedes all counting and includes it and supports it, namely (2) bi-univocal correspondence, the trait for trait.

Of course these detours could be for me a way of confirming the breadth, the infinity and the fruitfulness of what it is absolutely necessary for us to construct, for our part, starting from our experience. I am sparing you them.

If it is true that this is how things are, that analytic experience is the one which conducts us through the incarnated effects of what exists, of course, from all ages - but as regards which the fact that we are aware of them is the only new thing - the incarnated effects of the fact of the primacy of the signifier on the subject, it cannot but be that every kind of

attempt at reducing the dimensions of our experience to the already constituted point of view of what is called psychological science, in this sense that nobody can deny, can fail to recognise that it was established on premises which neglected, and with reason because it was avoided, this fundamental articulation on which we put the accent, this year simply in a still more explicit, tighter, more tightly knotted way, it cannot but be, I am saying, that any reduction to the point of view of psychological science as it has already been established by preserving as a hypothesis a certain number of opaque points, of avoided points, of points of major unreality, culminates necessarily at objectively lying - I am not saying mistaken, I am saying lying - falsified formulations which determine something which always manifests itself in the communication of what one can call an incarnate lie.

The signifier determines the subject, I tell you, in so far as necessarily this is what psychoanalytic experience means. But let us follow the consequences of these necessary premisses. This signifier determines the subject. The subject takes on a structure from it; it is the one that I already tried to demonstrate for you this year in connection with identification, namely with this something which focusses our experience on the very structure of the subject. I am trying to make you follow more closely this link of the signifier to the subjective structure.

What I am leading you to in these topological formulae which you have already sensed are not purely and simply this intuitive reference to which the practice of geometry has habituated you, is to consider that these surfaces are structures and I had to tell you that they are all structurally present at each one of their points, if indeed we must employ this word point without (3) reserving what I am going to contribute to it today.

I led you, through what I previously enounced, to the fact that it is now a matter now of setting up in its unity, that the signifier is cut and it is a matter of making this subject and its structure depend on that - this is possible by means of what I am asking you to admit and to follow me in at least for a while - that the subject has the structure of a surface at least topologically defined. It is a matter of grasping therefore - and this is not difficult - how the cut engenders the surface. This was what I began to exemplify for you in launching towards you, like so many little kites for some game or other, my Mobius surfaces, I also showed you that if you cut these surfaces in a certain way, they also become different surfaces, I mean topologically defined and materially graspable as changed because they are no longer Mobius surfaces from the very fact of this median cut that you have carried out, but a strip twisted a little about itself, but well and truly a strip, what is called a strip, like this belt that I have around my waist. It is to give you the idea of the possibility of the conception of this engendering which is in a way inverted compared to what first appears evident. It is the surface, you would think, which allows the cut, and I am telling you: it is the cut that we can

conceive of, by taking the topological perspective, as engendering the surface. And it is very important. Because when all is said and done it is here perhaps that we are going to be able to grasp the point of entrance, of insertion of the signifier into the real, confirm in human praxis that it is because the real presents to us what I might call natural surfaces that the signifier can enter it.

Of course, one can amuse oneself by bringing about this origin with concrete actions as they are called, in order to recall that man cuts and that God knows our experience is indeed one in which there has been highlighted the importance of this possibility of cutting with a pair of scissors. One of the fundamental images of the first analytic metaphors - the two little thumbs which are cut off with a snip of the scissor - is of course there to urge us not to neglect what is concrete, practical in it: the fact that man is an animal who prolongs himself with instruments, and in the foreground a pair of scissors. One could amuse oneself by redoing a natural history: what is the result for the few animals who have a pair of scissors in the natural state?

This is not what I am leading you to, and with good reason.

(4) What the formula "man cuts" (l'homme coupe) leads us to, is much more rather to its semantic echoes that he contradicts himself (il se coupe), as they say, that he tries to cut things short (y couper). All of this is to be gathered together in a different way around the fundamental formula: "it will be cut off you" (on t'la coupe)!

An effect of the signifier, the cut was first of all for us, in the phonematic analysis of language, this temporal, or more precisely sequential line of signifiers which I accustomed you to call up to the now the signifying chain. But what is going to happen if now I encourage you to consider the line itself as original cut? These interruptions, these individualizations, these segments of the line which are called, if you wish, on occasion phonemes, which are supposed therefore to be separated from the one which precedes and from the one which follows, to make a chain at least punctually interrupted; this "geometry of the sensible world" to which, the last time, I encouraged you to refer by reading Jean Nicaud and the work of that name, you will see in a central chapter the importance that this analysis of the line has in so far as it can be, I may say, defined by its intrinsic properties and how much easier it would have been for him to have put in the foreground, radically, the function of the cut for the theoretical elaboration that he has to erect with the greatest difficulty and with contradictions which are nothing other than the neglect of this radical function. If the line itself is cut, each one of its elements will then be a section of cut, and this is what in short is introduced by this lively [empty?] element, as I might say, of the signifier which I called the interior eight, namely precisely the loop (la boucle)♦ The line recuts itself: what is the interest of this remark?

The cut brought to bear on the real manifests here, in the real, what its characteristic and its function is, and what it introduces into our dialectic, contrary to the usage which is made of it that the real is the diverse: I have always made use of this original function, the real, to tell you that the real is what introduces the same, or more exactly the real is what returns always to the same place. What does that mean, if not that the section of the cut, in other words the signifier being what we have said: always radically different to itself - A is not identical to A - there is no way of making the same appear, except on the side of the real. In other words, the cut, if I can express myself in this way, at the level of a pure subject of cutting, the cut can only know it is closed, that it repasses through itself, because the real, as distinct from the (5) signifier, is the same. In other words, only the real closes it. A closed curve is the real revealed but as you see more radically it is necessary that the cut should recut itself if something has not already interrupted it. Immediately after the trait, the signifier takes this form which is properly speaking the cut; the cut is a trait which recuts itself, it is only after it is closed on the basis that, cutting itself, it has encountered the real, which alone permits to connote as the same, respectively what is found under the first, then the second loop.

We find here the knot which provides us with a recourse with respect to what constituted the uncertainty, the wavering of the whole identificatory construction. You will grasp it very well in the articulation of Jean Nicaud; it consists in the following: is it necessary to wait for the same in order that the signifier should consist, as it was always believed without dwelling sufficiently on the fundamental fact that the signifier, in order to engender the difference between what it signified originally, namely at once that particular time which, I assure you, cannot be repeated, but which always obliges the subject to rediscover it, this particular time requires therefore, in order to achieve its signifying form, the signifier to be repeated at least once and this repetition is nothing other than the most radical form of the experience of demand.

What the signifier incarnates are all the times that the demand is repeated. And if precisely the demand were not repeated in vain, there would be no signifier, because there would be no demand. If you had what the demand encloses in the loop (boucle), there would be no need for demand. There is no need for demand if need is satisfied.

A humorist cried one day: "Gentlemen, long live Poland, because if there were no Poland there would be no Poles". The demand is the Poland of the signifier. That is why I would be rather tempted today, parodying this accident of the theory of abstract spaces which brings it about that one of these spaces - and there are now more and more of them that I do not believe I am obliged to interest you in - is called Polish. Today let us call the signifier a Polish signifier and this will avoid you

calling it the loop (lac), which would seem to me a dangerous encouragement to the use that one of my fervent supporters thought he could make of term lacanism! I hope that at least while I am alive that this obviously tempting term will be spared me after my second death!

Therefore what my Polish signifier is designed to illustrate, is (6) the relationship of the signifier to itself, namely to lead us to the relationship of the signifier to the subject, if indeed the subject can be conceived of as its effect.

I already remarked that there is apparently only signifier, every surface where it is inscribed being supposed to it. But this fact is in a way imaged by the whole system of the Beaux-Arts which illuminates something which introduces you to questioning the architecture, for example on this ticket which makes it appear to you why the perspective is so reducibly trompe-l'oeil. And it is not for nothing that I also put the accent in a year whose preoccupations seemed to me to be very distant from properly aesthetic pre-occupations, on the anamorphose, that is to say for those who have not been here before - the use of the flight of a surface to make appear an image which is unrecognisable when unfolded, but which, from a certain point of view is gathered together and imposes itself.

This singular ambiguity of an art about what appears in its nature to be able to attach itself to depths and to volumes, to some completeness or other which, in fact, is always revealed as essentially subject to the interplay of planes and of surfaces is something just as important, interesting, as to see also what is absent from it. Namely all sorts of things that the concrete usage of extension offers us: for example knots, quite concretely imaginable as realisable in an architecture of undergrounds as perhaps the evolution of time will show us. But it is clear that never has any architecture dreamt of composing itself around an arrangement of elements, of rooms and communications, even of corridors, as something which would make knots inside itself. And nevertheless why not? This indeed is why our remark that there is no signifier unless a surface is supposed for it, is overturned in our synthesis which is going to look for its most radical knot in the fact that the cut, in fact, determines, engenders the surface, that it is what gives it its constituting reason as well as its varieties.

This indeed is the way that we can grasp, homologate this first relationship of demand to the constitution of the subject in so far as these repetitions, these returns in the shape of the torus these loops (boucles) which are renewed in describing what

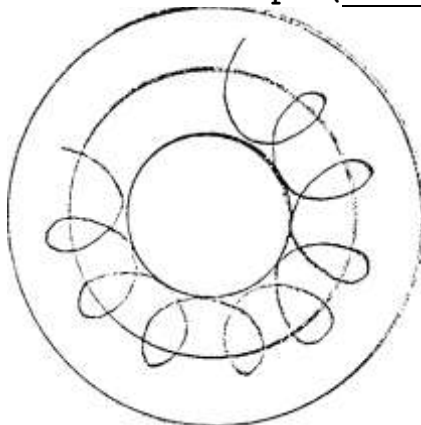

is presented for us, in the imagined space of the torus, as its contour, this return to its origin allows us to structure, to exemplify in a major fashion a certain type of relationship (7) of the signifier to the subject which allows us to situate in its opposition the function D of demand and

the o of the object; o , object of desire, D , the scansion of the demand.

You will have noticed that in the graph you have the following symbols $s(o)$; at the upper level $S(0)$, ^ cut of D ; at the two intermediary stages: $i(o)$, e , and on the other side, $\$$ cut of o , the phantasy... Nowhere will you see D and o connected. What does that express? What does that reflect? What does that support? It supports first of all the following: it is that what you find on the contrary is 3" cut of D and that these elements of the signifying treasury at the stage of enunciating, I am teaching you to recognise them, are what is called the Trieb, the drive. This is how the first modification of the real in the subject under the effect of the demand formalises it for you, it is the drive. And if in the drive, there were not already this effect of demand, this effect of the signifier, it could not be able to be articulated in such a manifestly grammatical schema. I am expressly making an allusion to what I suppose everyone here is accustomed to from my previous analyses; as regards the others I referred them to the article "Trieb und Triebchicksale" which has been bizarrely translated here by "Avatars des pulsions" no doubt through a sort of confused reference to the effects that the reading of such a text produces on the first obtuseness (obtusion) of the psychological reference

You see here the application of the signifier - which today, to amuse ourselves, we are calling the "Polish signifier" - to the surface of the torus:

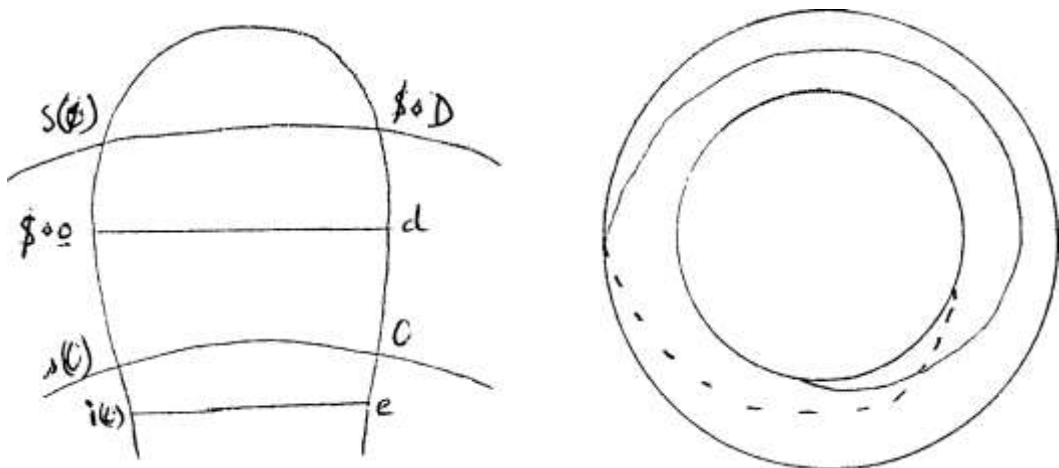

(8) It is the simplest form of what can be produced in an infinitely enriched fashion by a succession of twists around a spool, the spool properly speaking of the dynamo, in so far as in the course of this repetition the circuit is already made around the central hole. But in this most simple form that you see it drawn here, this circuit is also made, I underline - this cut is not the simple cut - in such a way that it does not recut itself. To image things: in real space, the one that you can visualise, you see it up to now in this surface presented to you, this face of the torus towards you, it subsequently

disappears onto the other face - that it why it is in a dotted line - in order to come back from this side.

Such a cut, as I might say, grasps absolutely nothing. Try it out on a bicycle tube, you will see at the end the tube opened out in a certain fashion, transformed into a surface twisted twice onto itself, but not at all cut in two. It renders, as I might say, graspable in a signifying and preconceptual fashion, but which is not at all without characterising a sort of grasp of its own kind of this radical thing of the flight, as one might say, the absence of any way of laying hold of its object at the level of demand. For if we have defined demand in the fact that it repeats itself and that it only repeats itself in function of an inside void that it rings, this void which sustains it and constitutes it, this void which does not involve - I point out to you in passing - any operation of an ethical or pleasantly pessimistic kind - as if there were something worse (un pire) going beyond what is ordinary for the subject, it is simply a necessity of a logical abc as I might say - every graspable satisfaction, whether one situates itself on the side of the subject or on the side of the object, is missed by demand. Simply in order that the demand should be demand, namely that it should be repeated as signifier it is necessary that it should be disappointed; if it were not, there would be no support for demand.

But this void is different from what is in question as regards o, the object of desire. The advent constituted by repetition, the metonymical advent, the one which slides, is evoked by the very sliding of the repetition of demand; o, the object of desire, can in no way be evoked in this void ringed here by the loop (boucle) of the demand. It is to be situated in this hole that we will call the fundamental nothing to distinguish it from the void of demand, the nothing from which the object of desire is called to become. What it is a matter for us of formalising with the elements that I am bringing you, is what allows there to be situated in the phantasy the relationship of the subject as $ij>$, the subject informed by the demand, to this o. While at (9) this level of the signifying structure that I am demonstrating for you in the torus, in so far as the cut creates it in this form, this relationship is an opposite relationship. The void which sustains the demand is not the nothing of the object that it rings as object of desire, it is this that the reference to the torus is designed to illustrate for you.

If this were all that you were able to get from it, it would be a lot of effort for a small result. But, as you are going to see, there are many other things to be got from it. In effect to go quickly and without of course making you go through the different steps of the topological deduction which show you the internal necessity which determines the construction that I am going to present to you now; I am going to show you that the torus allows something which undoubtedly you can see the cross-cap for its part does not allow.

I think that the most unimaginative people can see, through

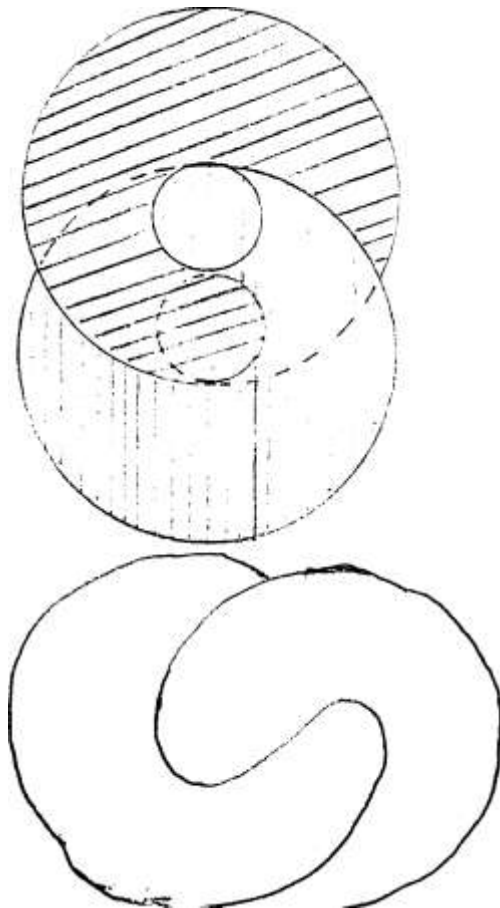

these topological windings, what is involved. Metaphorically at least, the term chain which implies concatenation has already sufficiently entered into the language for us not to have to dwell on it. The torus, through its topological structure, implies what we can call a complement, another torus which can come to concatenate with it.

Let us suppose that they are in complete conformity with what I asked you to conceptualise in the usage of these surfaces, namely that they are not metric, that they are not rigid, let us say they are capsule-like. If you take one of these rings with which one plays the game of that name, you will be able to see that if you take hold of one in a firm and fixed fashion, by its circumference and if you make turn back on itself the body of what has remained free, you will obtain

very

easily and in the same

fashion as if "yo" were using a curved reed, by twisting it in this way onto itself, you will make it come back to its first position without the torsion being in a way inscribed in its substance. Simply it will have come back to its primitive (10) point. You can imagine that by a torsion which would therefore be like this, one of these tori onto the other, we would proceed to what could be called a transfer (decalque) of anything whatsoever inscribed already on the first one that we will call 1, and let us suppose that what is involved is what I ask you to refer simply to the first torus: this curve, in so far as it does not simply englobe the thickness of the torus and that, it not alone englobes the space of the hole but it goes through it, which is the condition which can allow it to englobe at the same time the two voids, the nothings, both what is here in the thickness of the torus and what is here at the centre of the knot.

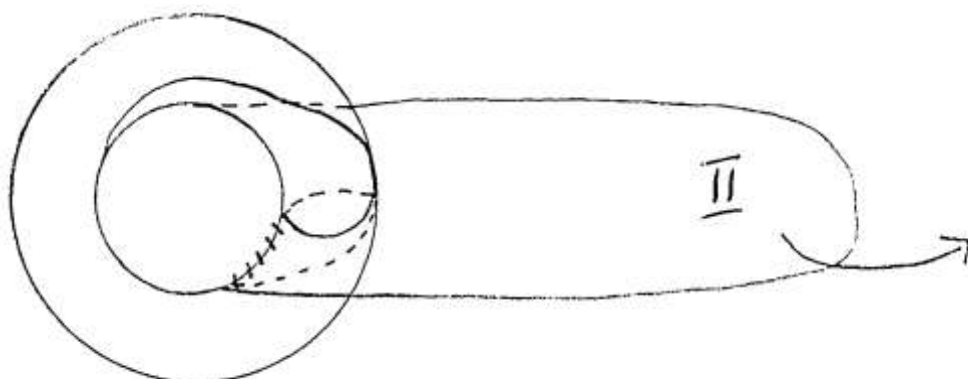

It can be proved - but I spare you the proof which would be long and would demand an effort from you - that in proceeding in this way what will come onto the second torus will be a curve superimposable on the first if one superimposes the two tori. What does that mean? First of all that they may not be superimposable. Here are two curves:

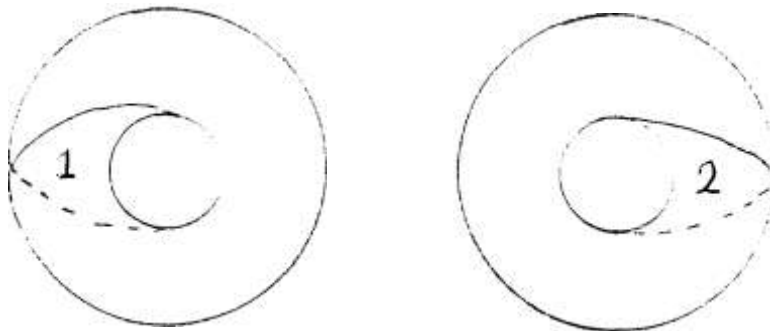

They appear to be made in the same way: they are nevertheless irreducibly not superimposable. This implies that the torus, despite its symmetrical appearance, involves possibilities of highlighting, through the cut, one of these effects of torsion which allows what I would call the radical asymmetry, whose presence as you know in nature is a problem for any formalisation, one which means that snails have in principle a direction of rotation which makes a great exception of those who have the opposite direction. There are a many phenomena of that (11) order, up to and including chemical phenomena, which express themselves in what are called polarising effects. There are therefore structurally, surfaces whose asymmetry is elective and which involve the importance of the dextrogyral or laevogyral gyration. You will later see the importance of what that signifies. You should only know that the phenomenon of the relationship by transfer (décalque) of what is produced as composing, englobing the loop of the demand with the loop of the central object, this relationship on the surface of the other torus, which you sense is going to allow us to symbolise the relationship of the subject to the big Other, will give two lines which, are superimposable with respect to the structure of the torus.

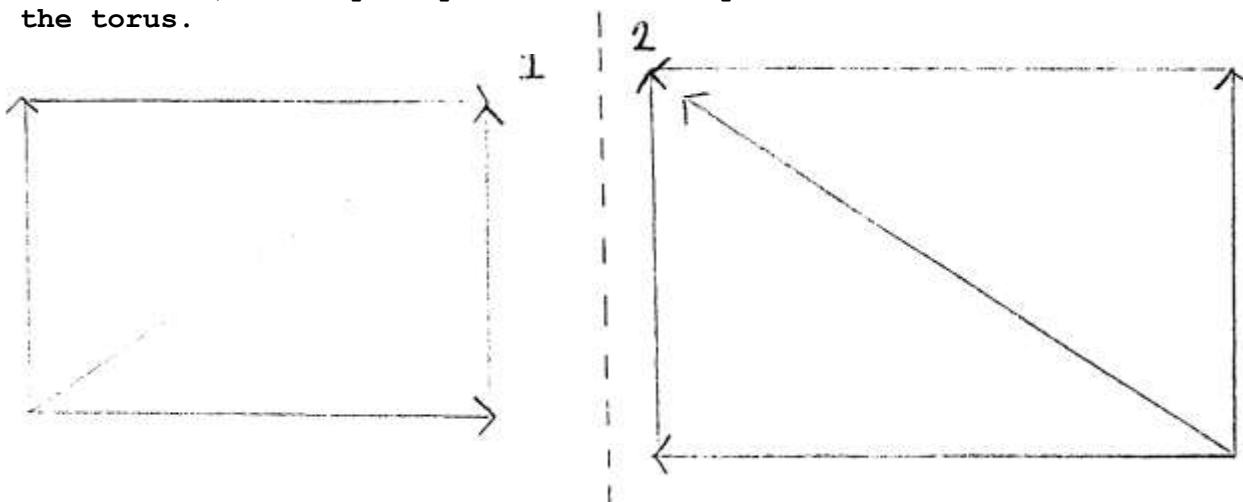

I apologise for making you follow a path which may appear arid to you, it is indispensable that I get you to sense the steps in

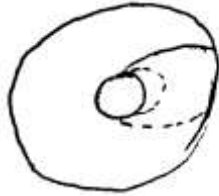

order to show you what we can draw from it.

What is the reason for that? It is very clearly seen at the level of what are called fundamental polygons. The polygon being thus described, you imagine in front of it its transfer which is inscribed as follows. The line involved on the polygon is projected here, as an oblique, and will be prolonged inverted on the other side on the transfer. But you ought to grasp that in making this fundamental polygon swing through 90 degrees you will reproduce exactly, including the direction of the arrows, the figure of this and that the oblique line will be in the same direction, this swing representing exactly the complementary composition of one of the tori with the other.

1

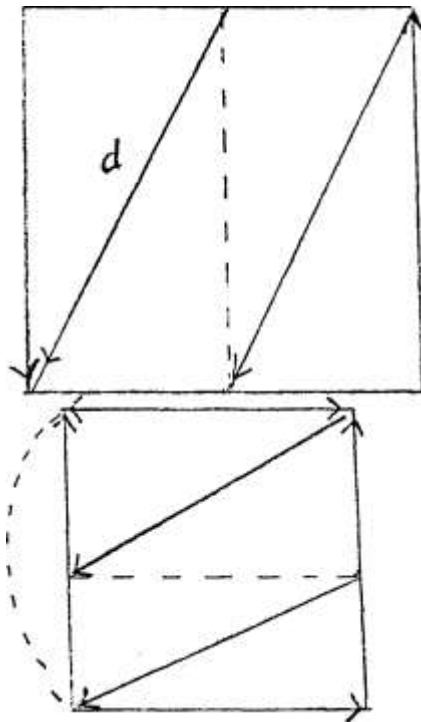

Now put onto the torus, no longer this simple line, but the repeated curve whose function I taught you earlier. Is it the same? I will spare your hesitations. After transfer and swing, what you will (12) have here is symbolised as follows:

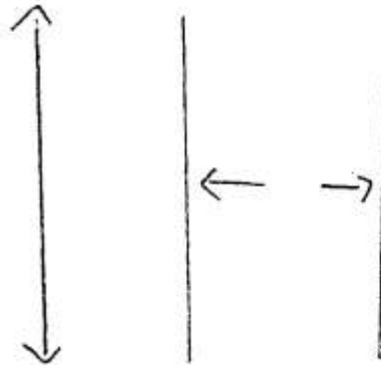

What does that mean? That means, in our signified transposition, in our experience, that the demand of the subject in so far as here it repeats itself twice, inverts its relationships: D and o, demand and object at the level of the Other, that the demand of the subject corresponds to the object o of the Other, that the object o of the subject becomes the demand of the Other.

This relationship of inversion is essentially the most radical form that we can give of what happens in the case of the neurotic: what the neurotic aims at as object, is the demand of the Other; what the neurotic demands, when he demands to grasp o, the ungraspable object of his desire, is o, the object of the Other.

The accent is put differently according to the two aspects of neurosis. For the obsessional the accent is put on the demand of the Other, taken as object of his desire; for the hysteric the accent is put on the object of the Other, taken as support for

his demand.

We would have to go into detail about what this implies in so far as what is in question for us is nothing other here than the access to the nature of this o. We will only grasp the nature of o when we have elucidated structurally in the same way the relationship of S to o, namely the topological support that we can give to the phantasy. Let us say, to begin to illuminate this path, that o, the object of the phantasy, o, the object of desire has no image and that the impasse of the neurotic's phantasy is that in his search for o, the object of desire, he encounters i of o. Such is the origin from which there starts the whole dialectic to which, from the beginning of my teaching, I have been introducing you, namely that the specular image, the understanding of the specular image depends on the fact, and I am astonished that nobody has thought of commenting on the function that I give it, the specular image is an error, it is not simply an illusion, a lure of the captivating Gestalt whose aggressivity has marked the accent. It is fundamentally an error in so far as the subject miscognises himself in it (s'y me-connait) if you will allow me the expression, in so far as (13) the origin of the ego and its fundamental miscognition are here reassembled in the spelling; and in so far as the subject is mistaken he believes that he has his own image in front of him; if he knew how to see himself, if he knew, what is the simple truth, that there are only the most deformed relationships in any identifiable fashion between his left-hand side and his right-hand side, he would not dream of identifying himself with the image in the mirror. When, thanks to the effects of the atomic bomb, we will have subjects with a right ear as big as an elephant's ear and, in place of the left ear, a donkey's ear, perhaps the relationships to the specular image will be better authenticated. In fact, many other more accessible and also more interesting conditions would be within our reach. Let us suppose another animal, the crane, with an eye on each side of her skull. It seems to be a mountainous task to know how there can be composed with one another the planes of vision of two eyes in an animal whose eyes are arranged in that way. One does not see why this opens up greater difficulties than for us. Simply, for the crane to have sight of her images, she has to be given two mirrors, and she will run no risk of confusing her left-hand image from her right-hand image.

This function of the specular image in so far as it is referred to the miscognition of what I called above the most radical asymmetry is the one which explains the function of the ego in the neurotic. It is not because he has a more or less twisted ego that the neurotic is subjectively in the critical position which is his, he is in this critical position because of a radically structuring possibility of identifying his demand with the object of the desire of the Other or of identifying his object with the demand of the Other, for its part a properly alluring form of the effect of the signifier on the subject, even though a way out of it is possible precisely when, the next time, I will show you how in another reference of the cut, the

subject qua structured by the signifier can become the cut o itself. But it is precisely what the phantasy of the neurotic does not accede to because he searches for its ways and its paths along an erroneous passage. Not at all that the neurotic does not know very well how to distinguish, like any subject worthy of this name, $i(o)$ from o , because they do not have at all the same value, but what the neurotic seeks, and not without foundation, is to arrive at o through $i(o)$. The path along which the neurotic persists - and this is very tangible in analysing his phantasy - is to get to o by destroying $i(o)$ or by fixing it.

I said first of all "by destroying", because it is the most (14) exemplary. It is the most exemplary; it is the phantasy of the obsessional in so far as it takes on the form of the sadistic phantasy and is not one. The sadistic phantasy as the phenomenological commentators do not fail to support it with all the excessive overflowings which allow them to fix it forever in ridicule, the sadistic phantasy is supposedly the destruction of the Other. And as the phenomenologists are not - let us say "lucky for them!" - authentic sadists but simply have the most common access to the perspectives of neurosis, they find in effect all the appearances necessary to sustain such an explanation. It is enough to take up a sadistic or a Sadian text for this to be refuted: not alone is the object of the sadistic phantasy not destroyed, but it is literally resistant to every trial as I frequently underline for you.

You should clearly understand that I do not even intend getting into here again what is involved in the meaning of the properly Sadian phantasy, as I may probably be able to do it next time. What I want to punctuate here is that what one could call the impotence of the sadistic phantasy of the neurotic reposes entirely on the following: it is that in effect there is indeed a destructive aim in the phantasy of the obsessional, but this destructive aim, as I have just analysed it, has the meaning not at all of the destruction of the other, object of desire but the destruction of the image of the other in the sense that I am situating it for you here, namely that precisely, it is not the image of the other because the other, o , object of desire, as I will show you the next time, has no specular image. There is indeed here a proposition, I agree, which is a little excessive...

I believe it to be not only entirely demonstrable but essential to understand what happens in what I would call the deviations in the neurotic of the function of phantasy. Because whether or not he destroys in a symbolic or imaginary fashion this image, $i(o)$, it is never this that will ever make him authenticate by any subjective cut the object of his desire for the good reason that what he is aiming either to destroy or to support - $i(o)$ - has no relationship for the simple reason of the fundamental asymmetry between $i(o)$, the support, and o , which does not tolerate it. What the neurotic moreover effectively ends up at is the destruction of the desire of the Other. It is indeed why he has gone irremediably astray in the realisation of his own.

But what explains it is the following, namely what makes the neurotic as one might say symbolise something along this path of his of aiming in phantasy at the specular image, is explained by (15) what I am materialising for you here: the asymmetry which has appeared in the relationship of the demand and the object in the subject compared to the demand and the object at the level of the Other, this asymmetry which only appears from the moment where there is properly speaking demand namely already two circuits, if I can express myself in this way, of the signifier and appears to express an asymmetry of the same nature as the one which is supported by the specular image; they have a nature which, as you see, is sufficiently illustrated topologically because here the asymmetry which would be the one that we would call specular would be this with this:

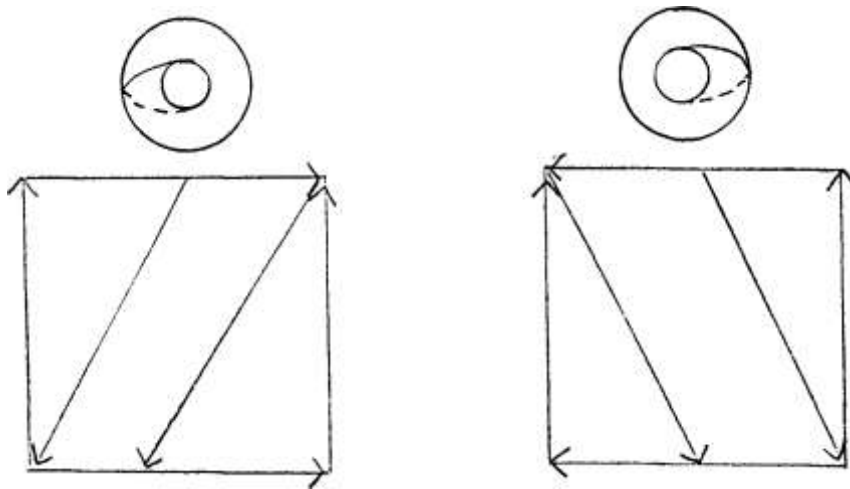

It is from this confusion through which two different asymmetries are found, for the subject, to serve as a support for what is the essential aim of the subject in his being, namely the cut of o , the veritable object of desire where the subject himself is realised, it is in this aim led astray, captured by a structural element which depends on the effect of the signifier itself on the subject that there resides not alone the secret of the effects of neurosis, namely that the relationship of what is called narcissism, the relationship inscribed in the function of the ego is not the true support of the neurosis; but in order that the subject should realise the false analogy, the important thing - even though getting close to, discovering this internal knot is capital in order to orientate us in the neurotic effects - is that it is also the only reference which allows us radically to differentiate the structure of the neurotic from neighbouring structures, namely from those which are called perverse and from those which are psychotic.

Seminar 23: Wednesday 6 June 1962

We are going to continue today to elaborate the function of what one can call the signifier of the cut, or again the interior eight, or again the loop, or again what I called the last time the Polish signifier. I would like to be able to give it a still less significant name in order to try to approach what is purely signifying in it.

We have advanced onto this terrain as it presented itself, namely with remarkable ambiguity, since as pure line nothing indicates that it recuts itself, as the shape in which I drew it there reminds you, but at the same time leaves open the possibility of this recutting. In short, this signifier does not prejudge in any way the space in which it is situated. Nevertheless in order to make something of it, we pose that it is around this signifier of the cut that there is organised what we are calling the surface, in the sense that we understand it here.

The last time, I reminded you - because it was not the first time that I showed it to you - how the surface of the torus can be constructed around, and only around, a cut, a cut arranged, manipulated in this quadrilateral fashion that the formula expressed by the sequence of an A, of a B, then of an A* and of a B¹, our witnesses respectively in so far as they can be referred to, coupled with the two preceding ones, in an arrangement that we can qualify, in general, by two terms oriented on the one hand, crossed on the other.

I showed you the relationship, what one might call at first sight the exemplary metaphorical relationship, regarding which precisely it is a question of knowing whether this metaphor goes beyond, as one might say, the pure plane of metaphor, the metaphorical relationship, I am saying, that it can take on, of the relationship of the subject to the Other, on condition that (2) in exploring the surface of the torus we perceive that we can put two tori qua linked to one another, into a style of correspondence such that to a particular privileged circle on one of the two, which we have made correspond for analogical reasons to the function of demand, namely this sort of turning circle in the familiar form of the spool which appears to us particularly suitable to symbolise the repetition of demand in so far as it involves this sort of necessity of completing itself, if it is ruled out that it recuts itself, after numerous repetitions, multiplied as we can imagine ad libitum, by

completing this buckling, to have described the circuit, the contour of a void other than the one that it rings, the one which we first distinguished as defining this place of the nothing, the circuit of which, drawn for itself, serves to symbolise for us - in the shape of the other circle topologically defined in the structure of the torus - the object of desire.

For those then who were not there (I know that there are some in this gathering) I illustrate what I have just said by this very simple shape, while repeating that this spool-buckle of demand.

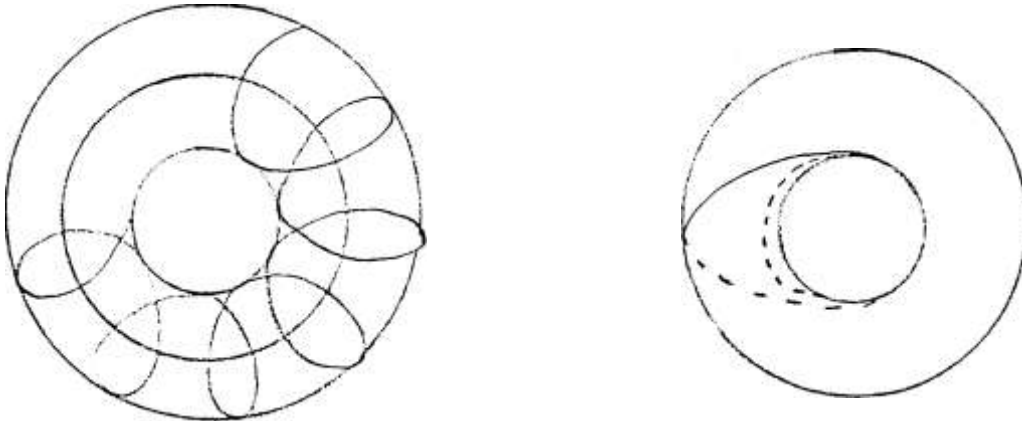

which is found around the constitutive void of the torus, is found to depict what serves us to symbolise the circle of the object of desire, namely all the circles which go around the central hole of the ring.

There are therefore two sorts of privileged circles on the torus

- those which are drawn around the central hole.
- and those which go through it.

A circle can have both properties at once. It is precisely what happens with this circle drawn as follows:

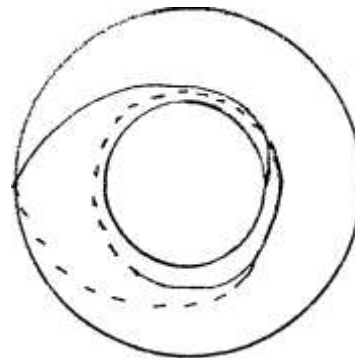

I put it in dots when it goes over to the other side.

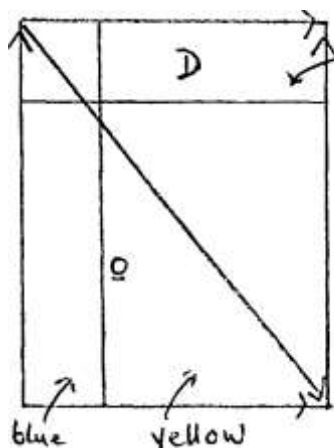

(3) On the quadrilateral surface of the fundamental polygon which serves to show in a clear and univocal fashion the structure of the torus, I symbolise here, to use the same colours, from here to here, a circle called the circle of demand, from here to here, a circle called circle o, symbolising the object of desire. And it is this circle here that you see on the first figure, which is here drawn in yellow, representing the oblique circle, which could at the limit serve to symbolise for us, as cut

of the subject, desire itself.

The expressive, symbolic value of the torus on this occasion, is precisely to make us see the difficulty, in so far as we are dealing with the surface of a torus and not another one, of arrangement this yellow circle of desire here, with this blue circle here of the object of desire.

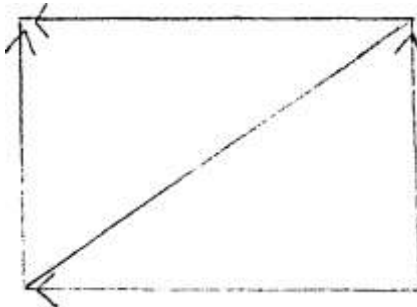

Their relationship is all the less univocal in that the object is not here fixed, determined by anything other than by the place of a nothing which, as one might say, prefigures its eventual place, but in no way allows it to be situated.

Such is the exemplary value of the torus.

You heard the last time that this exemplary value is completed by the fact that by supposing it enchainé, concatenated with another torus in so far as it would symbolise the Other, we see that undoubtedly this - as I told you - can be proved - I left you the job of finding this proof for yourselves in order not to delay - we see that undoubtedly by transferring (a decalquer) in this way the circle of desire projected onto the first torus, onto the torus which is fitted into it, symbolising the locus of the Other, we find a circle oriented in the same fashion.

Remember. You have, represented in front of this figure that I will begin again here if it does not appear too fastidious to you, the transfer which is a symmetrical image. We will have then an oblique line, oriented from north to south, which we can call inverted, specular properly speaking.

(4) But the ninety degree swing, corresponding to the interlocking at ninety degrees of the two tori will restore the same obliqueness. In other words, after having effectively taken - these are experiments which are very easy to carry out which have all the value of an experiment - these two tori and having effectively made, by the method of the rotation of one torus inside the other which I designated for you the last time, this transfer, having picked up as I might say the trace of these two circles arbitrarily drawn on the one and determined from then on on the other, you can see, by subsequently comparing them, that they are exactly, down to the circle which sections them, superimposable on one another.

This image then proves itself to be appropriate for representing the formula that the desire of the subject is the desire of the Other.

Nevertheless, I told you, if we suppose, not this simple circle drawn with this property, with this particular topological definition of at once encircling the hole and going through it, but make it go through the hole twice, and circle it once, namely

on the fundamental polygon to present it as follows (drawing), these two points here being equivalent, we have therefore something which, on the transfer, at the level of the Other, is presented according to the following formula:

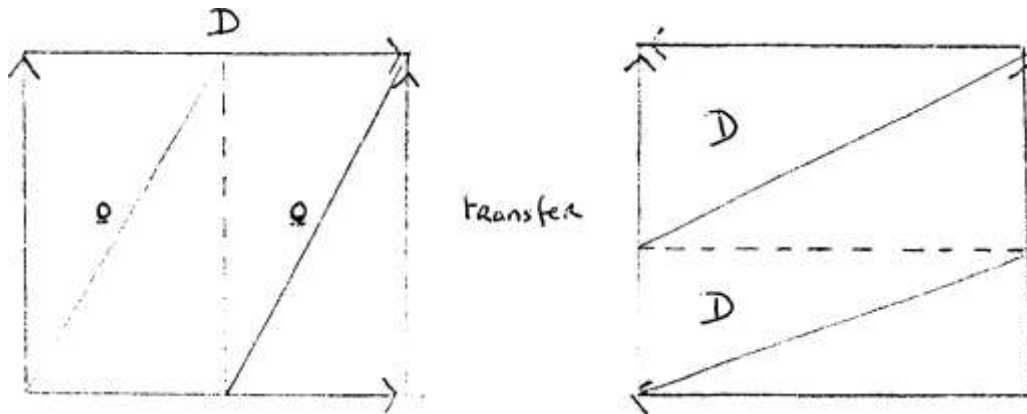

If you wish, let us say that the completion of two times the circuit, which corresponds to the function of the object and to the transferring (transfert) twice onto the transfer (decalque) on the other torus, of the demand according to the formula of equivalence which is precious for us on this occasion, is to symbolise the fact that in a certain form of subjective structure, the demand of the subject consists in the object of the Other, the object of the subject consists in the demand of the Other. Recutting: then the superimposition of two terms, after the swing, is no longer possible.

After the ninety degree swing (drawing) the cut is this one, (5) which is not superimposed on the preceding shape.

We have recognised in it a correspondence which is already familiar to us, in so far as what we can express about the relationship of the neurotic to the Other in as much as it conditions his structure down to its final term, is precisely this crossed equivalence of the demand of the subject to the object of the other, of the object of the subject to the demand of the other. One senses here in a sort of impasse or at least ambiguity the realisation of the identity of two desires.

This is obviously as abridged as possible as a formula and of course supposes already a familiarity acquired with these references, which presuppose our whole previous discourse.

The question then remaining open, the one that we are going to tackle today, about a structure which allows us to formalise in an exemplary fashion, rich in resources, in suggestions, which gives us a support for what precisely our research points towards, namely the function of the phantasy, it is to this end that we can make use of the particular structure called the cross-cap or the projective plane, in so far as I also gave you already enough pointers for this object to be, if not altogether familiar to you, at least that already you have tried to explore what it represents in terms of exemplary properties.

I apologise therefore for entering, from now on, into an explanation which, for an instant, is going to remain very closely linked to this object of a particular geometry described as topological, not a metric geometry but a topological geometry, with respect to which I already pointed out to you in passing as much as I could the idea you should have of it, so that eventually, after having taken the trouble to follow me in what I am now going to explain to you, you will subsequently be recompensed by what it will allow us to support as a formula concerning the subjective organisation which is the one which interests us, through what it will allow us to exemplify as being the authentic structure of desire in what one could call its central organising function.

Of course, I am not without some reluctance, once again, to be drawing you onto terrains which may not fail to tire you. This is why I will refer for a moment to two terms which happen to be close in my experience and which will give me the occasion - first of all a first reference - to announce to you the imminent (6) appearance of a translation by an eminent person who today does us the honour of his visit, namely M De Waehlens. M De Waehlens has just completed the translation - which one cannot but be very astonished was not done earlier - of Being and Time, Sein und Zeit, at least has brought to its point of completion the first part of a volume which has appeared and you know that it is only the first part of a project whose second part has never come to birth. Therefore in this first part, there are two sections; and the first section has already been already translated by M De Waehlens who did me the great honour, the favour, of sending it to me, which allowed me to get to know for myself this first part - still only the half of it - and I must say, with infinite pleasure, a pleasure that is going to allow me to offer myself another one: namely finally, in this place, something that has weighed on my heart for a long time and that I always spared myself from making a public profession of, because in truth, given the reputation of this work which I do not believe many people here have read, it might have looked like a provocation.

It is the following: it is that there are few texts more clear, indeed of a concrete and direct clarity and simplicity - I do not know what qualification I must invent to add a supplementary dimension to what is obvious - than the texts of Heidegger. It is not because what M Sartre has made of it is effectively rather difficult to read that this takes anything from the fact that this text here of Heidegger - I am not saying: all the others - is a text which carries in itself this sort of superabundance of clarity which renders it really accessible, without any difficulty, to any intelligence not intoxicated by a previous philosophical teaching.

I can tell you this now, because you will very soon have the opportunity of seeing it thanks to M De Waehlens¹ translation: you will see the degree to which it is so.

The second remark is this one, which you can confirm at the same

time: assertions are made, in the bizarre hack writings of a professional gossip that my teaching is neo-Heideggerian. This was said with injurious intent. The person probably put in a "neo" out of a certain prudence; as she knew neither what Heideggerian meant nor what my teaching meant either, this protected her from a certain number of refutations that this teaching of mine has really nothing neo nor Heideggerian about it, despite the great reverence I have for the teaching of (7) Heidegger.

The third remark is linked to a second reference, namely that something is going to come out - you are going to be spoiled in a little while - which is at least as important - indeed importance is not measured in different domains by centimetres - which is very important also let us say: it is the volume - which is not yet in the bookshops, I have been told, by Claude Lévi-Strauss, called La pensée sauvage.

It has appeared, you tell me. I hope that you have already begun to amuse yourselves. Because of the preoccupations that our seminar imposes on me, I have not got very far in it, but I read the magisterial inaugural pages, where Claude Lévi-Strauss enters into the interpretation of what he calls savage thinking, which must be understood - as, I think, his interview in Le Figaro has already informed you - not as the thinking of savages but as one might say the savage state of thinking, let us say: thinking in so far as it functions well, effectively, with all the characteristics of thought, without having taken on the form of scientific thought, of modern scientific thought with its status. And Claude Lévi-Strauss shows us that it is quite impossible to make here such a radical cut because the thinking which has not yet conquered its scientific status is already quite appropriate for carrying certain scientific effects.

Such, at least, is his apparent aim at the beginning, and singularly he takes as an example to illustrate what he means to say about it, about savage thinking, something where no doubt he intends to connect this something common there is between the thinking let us say as, he underlines it, as it has borne fundamental fruit starting from the moment itself which one cannot qualify as absolutely ahistorical since he specifies it: thinking starting from the neolithic era which gives, he tells us again, all its foundations to our sense of place in the world. To illustrate, as I might say, still functioning within our range, he finds nothing other and nothing better than to exemplify in a form which is no doubt not unique, but privileged by his demonstration under the form of what he calls bricolage.

This passage has all the brilliance that we know him to be capable of, the originality proper to this sort of abruptness, of novelty, of something which tips over and upsets banally accepted perspectives, and it is a piece which undoubtedly is very suggestive.

But it appeared precisely particularly suggestive for me, after (8) the re-reading that I had just carried out, thanks to M De

Waehlens, of Heideggerian themes, precisely in so far as he takes as an example in his research for the status, as one might say, of knowledge in so far as it can be established in an approach which to establish itself claims to make its way from the interrogation about what he calls "being there", namely at once the most veiled and the most immediate form of a certain type of being, the fact of being which is the one peculiar to the human being, one cannot fail to be struck, even though probably the remark would revolt both one and the other of these authors, by the surprising identity of the way both of them advance.

I mean that what Heidegger encounters first of all in this research, is a certain relationship of this being there to a being which is defined as utensil, as tool, as this something that one has at hand to use the term that he uses, as Zuhandenheit for what is to hand.

Such is the first form of the link, not to the world, but to being, that Heidegger outlines for us. And it is only starting from there, namely as one might say, in the implications, the possibility of such a relationship, that he is going, he says, to give its proper status to what constitutes the first great pivot of his analysis: the function of being in its relationship to time, namely the Weltlichkeit which M De Waehlens has translated by "les mondanités", namely the constitution in a way of the preliminary world, preliminary at this level of the being there which is not yet detached inside the being, these sorts of being that we could consider as purely and simply subsisting by themselves.

The world is something other than the totality, the englobing of all these beings which exist, subsist through themselves with which we have to deal at the level of this conception of the world which appears to us so immediately natural - and with good reason - because it is what we call nature. The anteriority of the constitution of this worldliness with respect to the moment that we can consider it as nature, this is the interval that Heidegger preserves by his analysis.

This primitive utensil-like relationship prefiguring the Umwelt still anterior to the environment which is only constituted, with respect to it, secondarily, this is the approach of Heidegger and it is exactly the same - I do not believe that I am saying anything here which might be taken as a critique which certainly, after everything that I know about the thinking and the statements of Claude Lévi-Strauss, might appear to us indeed to be the approach most opposed to his own in so far as the status (9) he gives to ethnographic research is supposed to be produced only in a position of aversion with respect to the metaphysical or even the ultra-metaphysical research of Heidegger - nevertheless it is indeed the same that we find in the first step by which Claude Lévi-Strauss wants to introduce us to savage thinking in the form of this bricolage which is nothing other than the same analysis, simply in different terms, a barely modified illumination, a name which is no doubt distinct from this same utensil-like relationship as being what both of them

consider as anterior, as primordial with respect to this sort of structured access which is ours with respect to the field of scientific investigation, in so far as it allows it to be distinguished as founded on an articulation of the objectiveness (l'objectité) which is supposed to be in a way autonomous, independent of what is properly speaking our existence and that we no longer keep with it anything but this so-called subject-object relationship which is this point at which there is resumed today everything that we can articulate about epistemology.

Well then let us say, to fix it once and for all, how our enterprise here in so far as it is based on analytic experience is distinct as compared to both one and the other of these investigations whose parallel character I have just shown you here. The fact is that we also are searching here for this status, as one might say, which is anterior to the classical access of the status of the object, entirely concentrated in the subject-object opposition. And we search for it where? In this something which, whatever may be the obvious character of approach, of attraction in the thinking of a Heidegger or of a Claude Levi-Strauss, is well and truly distinct from it because neither one nor the other names as such this object as object of desire.

The primordial status of the object for let us say in any case analytic thinking cannot be and could not be anything other than the object of desire. All the confusions with which analytic theory has been embarrassed up to now are the consequences of the following: of an attempt, of more than one attempt, of all the possible modes of attempt to reduce what is imposed on us, namely this search for the status of the object of desire, to reduce it to already known references of which the simplest and the most common is that of the status of the object of science in so far as a philosophising epistemology organises it in the final and radical opposition of subject-object in so far as an interpretation more or less weakened by the nuances of phenomenological research may at the limit speak about it as the object of desire.

(10) This status of the object of desire as such still remains eluded in all the forms of analytic theory articulated up to now; and what we are looking for here is precisely to give it its proper status. It is along this line that there is situated the perspective that I am pursuing before you for the moment.

Here are the figures in which today I am going to try to make you notice what interests us in this surface structure whose privileged properties are designed to retain us as a structuring support of this relationship of the subject to the object of desire, in so far as it is situated as supporting everything that we can articulate at whatever level it may be of analytical experience, in other words as this structure that we call the fundamental phantasy.

For those who were not at the last seminar, I recall this shape

here (sketch) drawn in white: this is what we call the cross-cap.

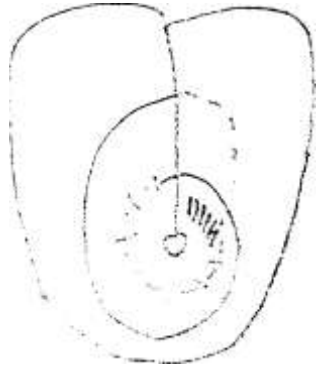

or to be more precise - since as I have told you, a certain ambiguity remains on the usage of this term cross-cap -: the projective plane. As its drawing here in white chalk is not enough, for those who have not yet grasped it, to represent for you what it is, I am going to try to make you imagine it by describing it to you as if this surface was constituted here as a bladder.

To be still more clear, I am going to start at the base. Imagine that you have two hoops like those of a wolf-trap (sketch) this is what is going to serve to represent the cut for us.

If we orientate the two circles of the wolf-trap in the same direction, this means that we are simply going to close them

(11) onto one another. If you have a bladder, precisely if you blow into it and if you close the wolf trap, it is all the same within the reach of elementary imaginings to see that you are going to make a sphere.

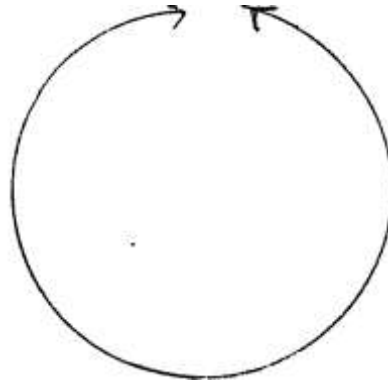

If blowing does not seem to you to be enough, fill it with water until you have obtained this shape here, close the two half-circles of the wolf-trap, and you have a half-full or a half-empty sphere.

I already explained to you how instead of doing that one can make a torus. This is what a torus is: you put the two corners of the handkerchief connected in the air like that and the two others underneath like that, and that is enough to make a torus. The essential of the torus is there, because you have here the central hole and here the circular void around which turns the circuit of the demand. This is what the fundamental polygon of the torus already illustrated for you. A torus is not at all like a sphere. Naturally a cross-cap is not at all like a sphere either.

Here you have the cross-cap (sketch). You ought to imagine it as being, as regards this lower half, realised like half of what you

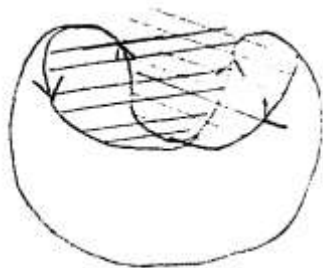

did earlier with the bladder when you filled it with water or with your breath; in the upper part what is anterior here will come to traverse everything that is continuous, what is here posterior. The two faces cross one another, give the appearance of penetrating one another; because the conventions concerning surfaces are free - because do not forget that we are only considering them as surfaces, that we can say that no doubt the properties of space as we imagine it force us, in the representation, to represent them as penetrating one another - but it is enough that we should take no account of this line of intersection at any of the moments of our treatment of this surface, in order for everything to happen

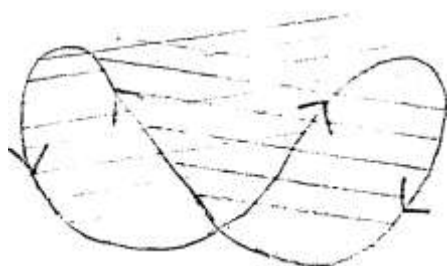

as if we held it to be nothing. It is not a hindrance. It is nothing but something that we are forced to represent for ourselves because we want to represent this surface here as a line of penetration. But this line, as one might say, has no privilege in the establishment of the surface. You will say to me: "What does what you are saying mean?" X in the audience: "Does it mean that you are admitting, with Kant's transcendental aesthetics the fundamental constitution of space in three dimensions, since you tell us that to present things here you are forced to pass by way of something which in the representation is in some way awkward?" Of course, in a certain way, yes. Everyone who articulates anything about the topology of surfaces as such starts - it is the abc of the question - from this distinction between what one can call the intrinsic properties of the surface and the extrinsic properties. They will tell us that everything they are going to articulate, determine, concerning the functioning of surfaces thus defined, is to be distinguished from what happens - as they literally express it - when one plunges the aforesaid surface into space, specifically in the present case in three dimensions.

This is the fundamental distinction that I too have reminded you of incessantly in order to tell you that we should not consider the ring, the torus as a solid and, that when I speak about the void which is central, about the circumference of the ring, as well as of the hole which is as we might say axial to it, these are terms that must be taken within the context that we do not have to make them function in so far as we are aiming purely and simply at the surface.

It nevertheless remains true that it is in so far, as the topologists put it, as we plunge into a space that we can leave

at the state of x - we are not obliged to prejudge the number of dimensions that structure it - that we can highlight one or other of the intrinsic properties that are involved in a surface.

And the proof is precisely the following: it is that we will have no difficulty in representing the torus in the three dimensional space which is intuitively familiar to us, while for this one we will all the same have a certain amount of trouble because we will have to add on to it the little note of all sorts of reservations concerning what we have to read when we try to represent this surface in this space.

This is what will allow us to pose precisely the question of the (13) structure of a space in so far as it admits or it does not admit our surfaces as we have previously constituted them.

With these reservations, I would ask you now to pursue and to consider what I have to teach you about this surface precisely in so far as it is in connection with its representation in space that I am going to try to highlight for you certain of its characteristics, which are no less intrinsic for all that.

Because if I have already eliminated the value that we can give to this line, the line of penetration, whose detail you see illustrated here - this is how we can represent it (see the sketch) - you see that simply by the way in which I, for my part already drew it on the blackboard, there is here something which poses a question.

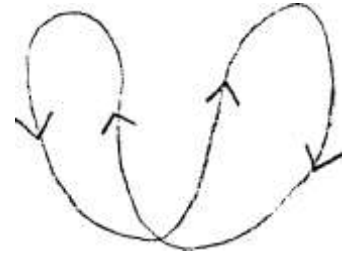

Is the value of the point which is here a value that we can in a way efface like the value of this line? Is this point also for its part something which only depends on the necessity of representation in three-dimensional space? I am telling you this right away to clarify my account a little in advance: this point, as regards its function, cannot be eliminated, at least at a certain level of speculation about the surface, a level which is not simply defined by the existence of three-dimensional space.

In effect, what does the construction of this surface called the cross-cap signify radically, in so far as it is organised starting from the cut that I represented for you earlier as a wolf-trap that closes?

Nothing more simple than to see that this wolf-trap must be bi-partite, when the sphere is involved, because it is necessary that it should fold back on itself somewhere, that its two halves are orientated in the same direction: the terminus a quo will be distinguished therefore from the terminus ad quod in as much as they must overlap lengthways.

We can say that here (sketch) we have the way in which there function with respect to one another the two halves of the edge

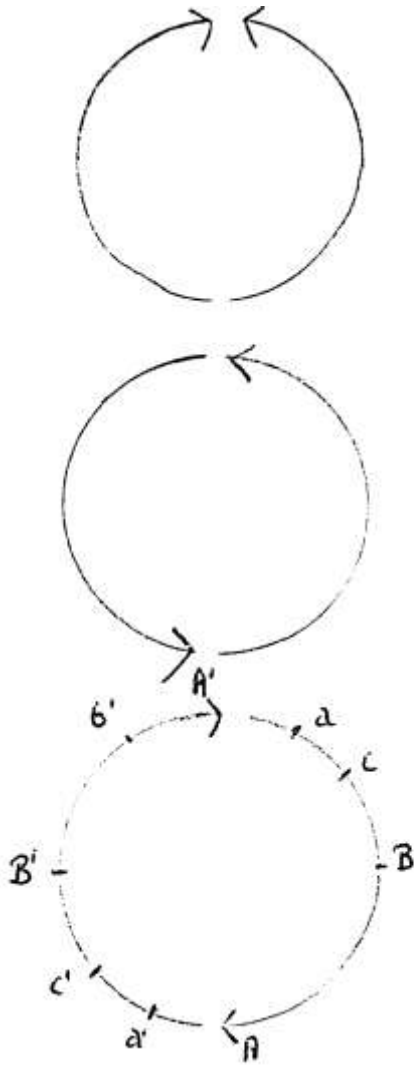

that must be connected in order to constitute a projective (14) plane. Here (sketch) they are oriented in a contrary direction, which means that a point situated at this place, point a for example, will correspond, will be identical, equivalent, to a point situated at this place in a* diametrically opposite, that another point b situated here for example will refer to another point b^1 situated diametrically.

Does this not encourage us to think that given this antipodal relationship of the points oriented on this circuit in a continuous fashion always in the same direction, no point will be privileged and that, whatever may be our difficulty in intuiting what is involved, we have simply to think about this circular antipodal relationship as a sort of radiating intercrossing as one might say, concentrating the exchange of one point with the opposite point of the single edge of this hole, and in concentrating it, as one might say, around a vast central interlacing which escapes our thinking and which does not allow

us in any way therefore to give a satisfactory representation of

Nevertheless what justifies things being represented in this way, is that there is something that should not be forgotten: it is that it is not a question of metric figures, namely that it is not the distance between a and A, and from a' to A' which regulates the point by point correspondence which allows us to construct the surface by organising the cut in this way, but it is uniquely the relative position of points, in other words in a set of three points which are situated on the half - admit the usage of the term half that I make use of on this occasion, which is already represented by the analogical reference that I made here of two halves of an edge - it is in so far as on this edge, on this line, as on every line, a point can be defined as being between two others that a point c for example is going to be able to find its correspondent in the point c' of the other side...

But, if we do not have a point of origin, an archen point, "ten archèn o ti kài lalb umin" Saint John VIII 25, as it is expressed in the gospel something which lends itself to so many difficulties in translation that a thinker from Franche-Comte (15) could say to me: "That's just like you: the only passage in

the gospel on which nobody can agree is the one you took as an epigraph for a section of your Rome report". Archen, therefore the beginning, if there are not these starting points somewhere, it is impossible to define a point as being between two others, because c and c' are moreover between these two others a and B if there is no AA* to locate in a univocal fashion what is happening in each segment.

It is therefore reasons other than the possibility of representing them in space that make it necessary for us to define a point of origin for this intersecting exchange which constitutes the surface of a projective plane between an edge which it is necessary for us, despite the fact that it turns always in the same direction, to divide in two.

This may appear extremely tiresome for you, but you are going to see that it is going to take on a greater and greater interest.

I announce to you right away what I intend to say.

I intend to say that this archen point of the origin has an altogether privileged structure, that it is it, it is its presence, which guarantees for the interior loop of our Polish signifier, a status which is altogether special to it.

In effect, so as not to make you wait any longer, I apply this signifier, called the interior eight, onto the surface of the cross-cap. We will see afterwards what that means. Observe all the same that to apply it in this way means that this line that our interior eight outlines finds itself here turning twice around this privileged point (sketch).

Here, make an effort of imagination. I am quite happy to illustrate it for you by something; look at what comes out of this (sketch).

You have here, if you wish, the bulge of the lower half, the bulge of the left pincer of the lobster's foot, the bulge of the right pincer.

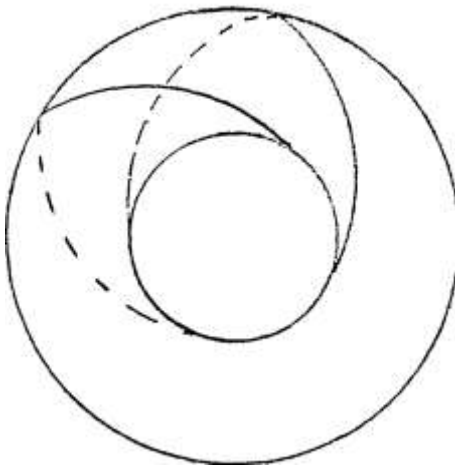

(16) Here this goes into the other one, it goes to the other side. What does that mean? That means that you have something like a plane which rolls up like that on itself, then which at a moment traverses itself. So that it behaves like two kinds of shutter or flapping wings superimposed here which find themselves in short isolated by the cut from the lower swelling, and at the upper level these two wings cross one another. It is not too unimaginable.

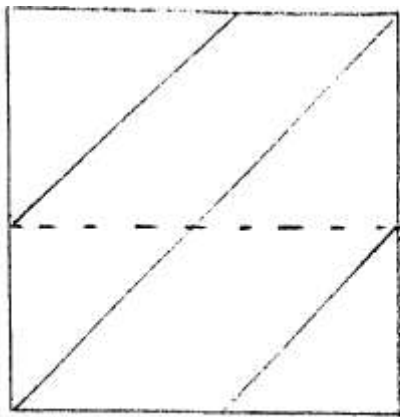

If you had interested yourselves as long as I have in this object, obviously there would be little surprising in this. Because in fact the privilege this double cut has is very interesting. It is very interesting in the sense that, as regards the torus, I already showed you, if you make a cut, it is transformed into a strip; if you make a second one, which traverses the first, this does not for all that fragment it, this is what allows you to spread it out like a fine square. If you make two cuts which do not intersect, on the torus - try to imagine that - then you would necessarily make two parts of it.

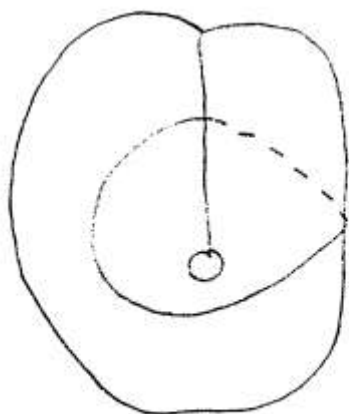

Here, on the cross-cap, with a simple cut like the one which can be drawn here thus (sketch) will open up this surface. Amuse yourself by making a drawing of it, it will be a very good intellectual exercise to know what happens at that moment. You cut it in two, you do not make two

open the surface, you do not parts of it.

If you make any other cut whatsoever which intersects itself or (17) does not intersect itself, you divide it.

What is paradoxical and interesting, is that in short it is always only a question of a single cut here and that nevertheless, by simply making it turn twice around the privileged point, you divide the surface.

It is not the same at all on a torus. On a torus, if you turn around the central hole as often as you wish, you will never obtain anything but a lengthening in a way of the strip, but you will not divide it for all that.

This, in order to make you notice that we are touching here, no doubt, something interesting about the function of this surface.

There is moreover something which is no less interesting: it is that this double circuit, with this result, is something that you can only repeat one more time; if you make a triple circuit, you will be led to draw on the surface something which will indefinitely repeat itself like the loops that you draw on the torus, when you engage in this spooling operation about which I spoke to you at the beginning, except for the fact that here the line will never connect up with itself, will never bite its own tail.

The privileged value of this double circuit is therefore sufficiently guaranteed by these two properties.

Let us consider now the surface that this double circuit isolates on the projective plane. I am going to point out certain properties of it for you.

First of all, it is what we can call a surface - let us call it that, for rapidity, between ourselves, as one might say, because I am going to remind you what that means -; it is a left-handed surface, like a left-handed body, like anything at all that we may define like that in space. I am not using it to oppose it to the right, I am using it to define the following, which you ought to know well: it is that if you want to define the rolling up of a snail who, as you know, is privileged dextrogyre or levogyre, it does not matter, it depends how you define one or other of them - you will find this winding is the same whether you look at the snail from the side of his head or whether you turn him around to look at it from the side of the place where there is a hollow.

In other words, it is by turning over the cross-cap here in order to see it from the other side, if we define here the rotation (18) from left to right by distancing ourselves from the central point, you will see that it always turns in the same direction on the other side, figure B.

This is the property of all bodies which are asymmetrical. It is therefore an asymmetry which is fundamental to the shape of this surface that is involved.

As proof, the fact is that you have underneath something which is the image of this surface defined in this way on our double loop, in the mirror. Here it is. We should expect that, as in any asymmetrical body, the image in the mirror is not superimposable on it, just as our image in the mirror, with regard to us who are not symmetrical despite what we think, is not superimposed at all on our proper support. If we have a beauty spot on the right cheek, this beauty spot will be on the left cheek of the image in the mirror.

Nevertheless, the property of this surface is such that, as you see, it is enough to raise this loop here a little - which is legitimate - to make it pass over the other one, since the two planes do not really traverse one another, in order that you should have an image (3) absolutely identical to and therefore superimposable on the first one, the one with which we started (1). Figure C.

You see what is happening: lift this very gently, progressively up to here, and see what is going to happen, namely that the occultation of this little part in dots situated here is the identical realisation of what is in the primary image.

This serves to illustrate for us this property which I told you was that of o qua object of desire, of being this something which

is at once orientable and undoubtedly very oriented, but which is not, if I can express myself in this way specularisable.

At this radical level which constitutes the subject in his dependence with respect to the object of desire, the function i of o , the specular function, loses its hold as one might say.

And all of this is determined by what?

By something which is precisely this point (central point) in so far as it belongs to this surface.

(20) To clarify immediately what I mean, I will tell you that it is in articulating the function of this point that we will be able to find all sorts of auspicious formulae which allow us to conceive the function of the phallus at the centre of the constitution of the object of desire. It is for this reason that it is worth our trouble to continue to interest ourselves in the structure of this point.

I must pause for a moment to show you what is the true function of this point, in so far as it is the key to the structure, of the surface defined in this way, cut out by our cut on the projective plane. This is something that is going to demand from you of course, a little more patience.

What is the function of this point?

What is there, at this moment at which we pause, is manifest, is that it is in one of the two parts by which the projective plane is divided by the double cut. It belongs to this part which is detached, it does not belong to the part which remains. (Figure D).

Since it seems that you were capable earlier - I must all the same infer this from the fact that no murmur of protestation was raised - of conceiving how this figure can pass to this one by a simple legitimate displacement at the level of the cut, you are going, I think, to be just as capable of making the mental effort of seeing what happens if, on the one hand, we are going to make this cut break through the horizon of the lower cul de sac of the surface by making it pass over therefore to the other side, as my yellow arrow indicates and if we also make breakthrough to the upper part of the loop the horizon of what is on top of the cross-cap. (Figure D).

This leads us without difficulty to the following figure.

The passage to the last one is a little bit more difficult to conceive of, not for the lower loop as you see, but for the upper loop in so far as you may perhaps have a moment of hesitation about what happens at the moment of breaking through what is presented here as the extremity of the line of penetration.

If you reflect on it a little, you will see that if it is from the other side that the cut is brought to break through this line

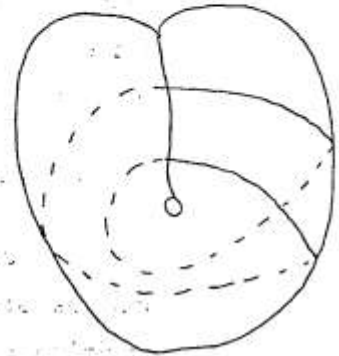
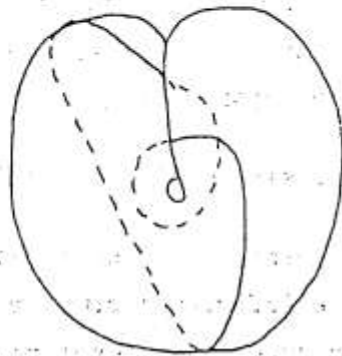
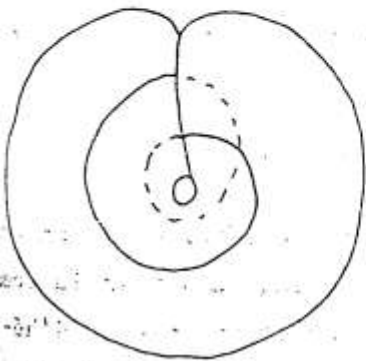
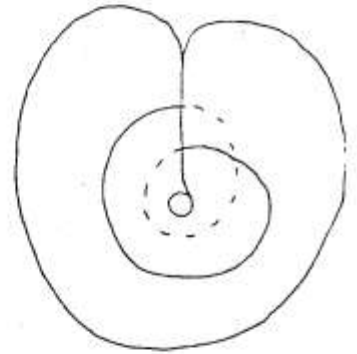
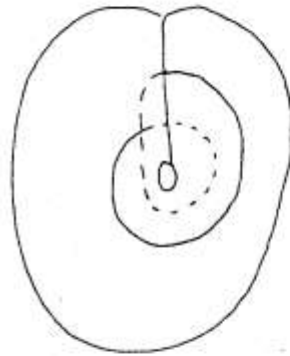
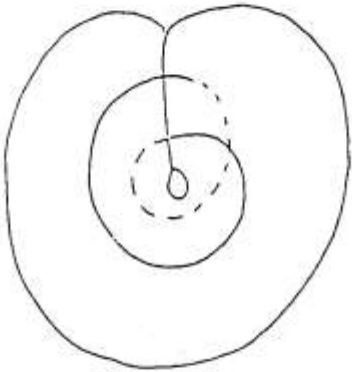
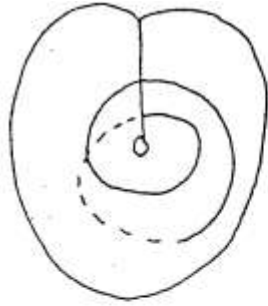
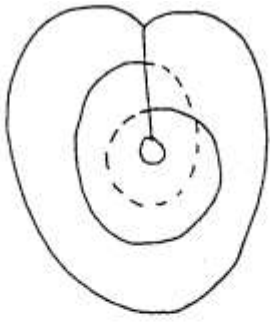

of penetration, obviously it will present itself like that, namely, as it is on the other side, it will be dotted on this side, and it will be unbroken because according to our convention (21) what is dotted is seen by transparence.

Nothing in the structure of the surface allows us to distinguish the value of these cuts 1 and 2, therefore of those at which we culminate here. For the eye, they present themselves as both entering on the same side of the line of penetration.

Is it very simple for the eye? Surely not. Because this difference that there is between, for the cut to enter from two different sides (1) or to enter by the same side (3), is something which ought all the same to be signaled in the result, on the figure. And moreover this is quite tangible. If you reflect on what it is, you will easily recognise what from now on is cut out on this surface:

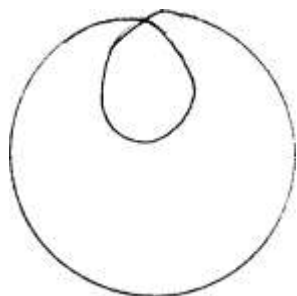

first of all, it is the same thing as our signifier; what is more in the way in which it cuts out a surface, it cuts out a surface which you sense very well - you only have to look at the figure - is a strip, a strip which has no edge. I already showed you what it is: it is a Möbius surface.

Now, the properties of a Möbius surface are properties completely different to those of this little rotating surface whose properties I showed you earlier by turning it, by aiming at it, by transforming it and by telling you finally that this is what interests us.

This little conjuring trick has obviously a reason which is not hard to find. Its interest is simply to show you that this cut always divides the surface into the two parts, one of which preserves the point involved on its inside, and the other which no longer has it.

This other part which is just as present there (1) as in the terminal figure (3), is a Möbius surface. The double cut always divides the surface called the cross-cap in two: this something that we are interesting ourselves in and which I am going to make (22) the support for you of the explanation of the relationship of \mathbb{R} with \mathbb{O} in the phantasy, and, on the other side a Möbius surface.

What is the first thing that I made you put your finger on when I made you a present of these five or six little Möbius surfaces which I launched through the audience?

It is that the Mobius surface, for its part, in the sense that I understood it earlier, is irreducibly left-handed. Whatever modification you may make it undergo, you can never superimpose on it its image in the mirror.

Here therefore is the function of this cut and what it shows to be exemplary. It is such that, dividing a certain surface in a privileged fashion, a surface whose nature and function are completely enigmatic to us, because we can scarcely situate it in space, it makes appear privileged functions on the one hand, which are those which I called above being specularisable, namely involving its irreducibility to the specular image, and, on the other hand, a surface which, while presenting all the privileges of a surface for its part oriented, is not specularised. Because notice carefully that one cannot say of this surface, as one can about a Mobius surface, that an infinitely flat being moving along it finds itself all of a sudden on this surface on its own reverse side: each face is well and truly separated from the other in this:

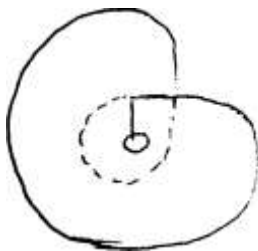

this property, of course, is something which leaves open an enigma; because it is not so simple, all the less simple that the total surface - it is quite obvious, is only reconstitutable, and immediately reconstitutable, if we start from this:

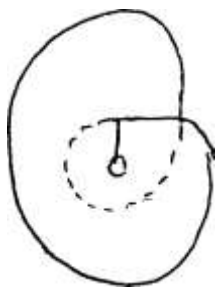

(23) It is necessary therefore that the most fundamental properties of the surface be preserved somewhere, despite its more rational appearance than that of the other, in the surface.

It is quite clear that they are preserved at the level of the point. If the passage which in the total figure always makes it possible for an infinitely flat traveller to find himself by an excessively short path at a point which is its own proper reverse

- I am saying: on the total surface - if it is no longer possible at the level of the central surface, fragmented, divided by the signifier of the double loop, it is because very precisely something of this is preserved at the level of the point.

Except that precisely for this point to function as this point, it has this privilege of being precisely unsurmountable, you make vanish, as one might say, the whole structure of the surface.

As you see, I have not been able yet to give its full development to what I have just said about this point. If you reflect on it, you will be able, before the next time to find it yourselves.

Time is passing, and it is indeed here that I am forced to leave you. I apologise for the aridity of what I was led to produce before you today, because of the very complexity, even though it is only an extraordinarily punctual complexity, it must be admitted. This is what I will take up the next time.

I come back therefore to what I said at the beginning: the fact that I could only get to this point of my account means that next Wednesday's seminar - tell those who have received the next announcement - will be held in order not to leave too much space, too much of an interval between these two seminars, because this space could be harmful for the continuation of our explanation.

Seminar 24: Wednesday 13 June 1962

Here are three figures. Figure 1 corresponds to the simple cut in as far as the projective plane cannot tolerate more than one without being divided. This one here is not divided, it opens out. This opening is interesting to show in this form, because it allows you to visualise, to materialise the function of the point.

Figure 2 will help you to understand the other one. It is a matter of knowing what happens when the cut designated here has opened out the surface. Of course, here it is a matter of a description of the surface linked to what are called its extrinsic relationships, namely the surface in so far as we are trying to insert it into a three-dimensional space. But I told you that this distinction between the intrinsic properties of the surface and its extrinsic properties was not as radical as people with an eye for formalism sometimes insist, because it is precisely in connection with its being plunged into space, as it is put, that certain intrinsic properties of the surface appear with all their consequences. I am only pointing out the problem to you. Hence what I am going to tell you in effect about the projective plane, the privileged place that will be occupied in it by the point, what we will call the point, which is here depicted in this cross-cap, here the terminal point of the line, the pseudo-penetration of the surface onto itself. You see the function of this point in this open shape of the same object described in figure 1. If you open it along the cut, what you are going to see appearing is a bottom which is below, that of the half-sphere. Above, it is the plane of this anterior wall in so far as it continues into a posterior wall, after having penetrated the plane which for its part is, as one might say, symmetrical in the composition of this object. Why do you see it stripped bare in this way up to the top? Because once the cut has been made, since these two planes which cross one another, like this, at the level of the line of penetration, do not really cross one another, it is not a real penetration that is involved, but a penetration which is required by the projection into space of the surface we are dealing with. We can, at our whim, once a cut has dissolved the continuity of the surface, lift up one of these planes across the other since moreover not only is it not important to know at what level they traverse one another, what points correspond in the traversing, but on the contrary it is good not to take into account deliberately this coincidence of levels of points in so far as the penetration may render them, at

certain moments of reasoning, superimposable. On the contrary, it would be well to remark that they are not. The anterior plane of figure 1, which passes from the other side found itself lowered towards the point that we now call from now on quite simply the point, while above we see the following being produced: a line which goes to the top of the object and which, behind, passes to the other side. When we carry out a crossing (traverse'e) on this figure, we obtain something which presents itself as an open hollow towards the front. The trait in dots is going to pass behind this sort of ear and finds an exit on the other side, namely the cut between this edge here and that which, from the other side, is symmetrical to this sort of basket, but behind. It must be considered that behind there is a way out.

Here is figure 3 which is an intermediate figure. Here you see again the interlacing on the upper part of the anterior plane, which becomes posterior and subsequently returns. And as I already pointed out to you, you can lift that up indefinitely. This indeed is what is produced at the extreme level. It is the same thing as this edge here that you find described in figure 1. This part which I designate in figure 1 we are going to call A. This is what is maintained at this place in the figure. The continuity of this edge is made with the one which, behind the sort of oblique surface thus separated out, folds itself back once you have begun to let the whole lot go. So that if one stuck them together again this would rejoin itself like in figure 3. This is why I indicated it in blue on my drawing. The blue is, in short, all that the cut itself perpetuates.

What results from it? The fact is that you have a hollow, a pocket into which you can introduce something. If you pass your hand through it, it passes behind this ear which is in continuity from the front with the surface: what you encounter behind is a (3) surface which corresponds to the bottom of the basket but separated from what remains on the right, namely this surface which comes forward here, and which folds itself back to figure 2. In following a path like that one you have an unbroken arrow, then one in dots because it passes behind the ear which corresponds to A. It comes out here because it is the part of the cut which is behind. It is the part that I can designate here by B. The ear which is outlined here by the limits of this dotted line in figure 2 could be on the other side. This possibility of two ears, is what you will discover when you have realised the double cut and when you isolate in the cross-cap something which is fabricated here. What you see in this central piece of figure 4 isolated in this way, is in short a plane such that you now efface the rest of the object, so that you will no longer have to put in the dots here nor even the traversal: there remains only the central piece.

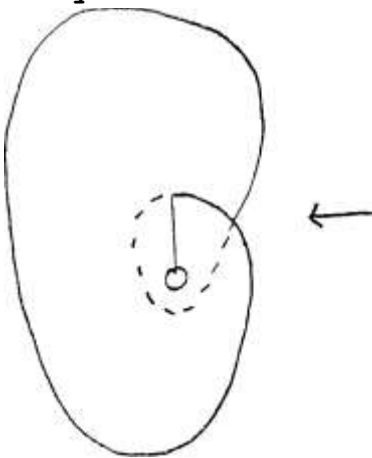

What do you have then? You can easily imagine for yourselves

with a sort of plane which by going out of true comes, at a moment, to recut itself by means of a line which then passes behind. You have therefore, here also, two ears, a lamella in front, a lamella behind. And the plane traverses itself according to a line strictly limited by a point. It could be that this point was placed just at the extremity of the posterior ear, this would be, for the plane, a way of recutting itself which would be just as interesting from certain points of view since it is what I realised in figure 5 to show you earlier the proper way to consider the structure of this point.

I am aware personally that you have already become disturbed about the function of this point because one day you posed me the question in private of why I and the other authors always represent it in this form, indicating at the centre a sort of little hole. It is quite certain that this little hole gives rise to reflections. And it is precisely on it that we are going to insist, because it gives the quite particular structure of this point which is not a point like the others. This is what I (4) am going to be led to explain now.

Its rather oblique, distorted shape is amusing, because the analogy between the helix, the antelix and even the lobule, and the shape of this cut projective plane is striking, if one considers that one can rediscover this shape which fundamentally is drawn towards the shape of the Möbius strip.

It is found much more simplified in what I once called the arum or again the donkey's ear. This is done only to draw your attention to the obvious fact that nature seems in a certain way drawn by its structures, and in particularly significant organs, those of the orifices of the body which are in a way left to one side, distinct from the analytic dialectic. To these orifices of the body, when they show this sort of resemblance, could be linked a sort of consideration about the attachment of this point to Naturwissenschaft, which ought indeed to relate to it, to be reflected in it if it has effectively some value.

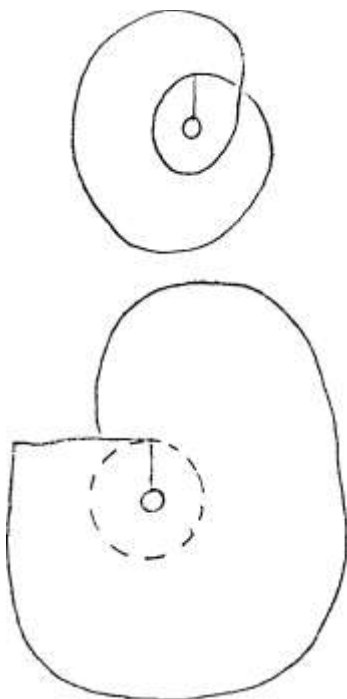

The striking analogy between many of these drawings that I have made with the figures that you find on every page of books on embryology also deserves to retain our attention. When you consider what happens, scarcely has the stage of the germinative plaque been gone through in serpents' or fishes' eggs - in so far as it is what is closest, according to an examination which is not absolutely complete in the present state of science, to the development of the human egg - you find something striking, it is the appearance on this germinative plaque, at a given moment, of what is called the primitive line which also terminates at a point, Hensen's node, which is a quite significant and really

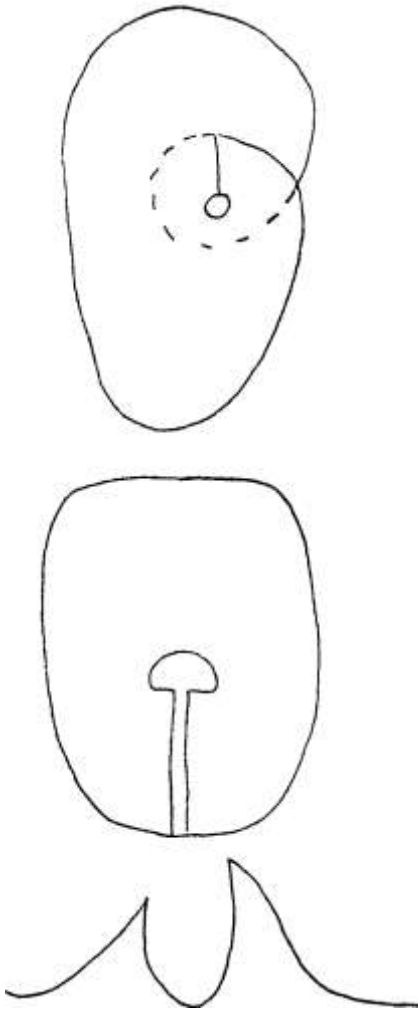

problematic point in its formation in so far as it is linked by a sort of correlation to the formation of the neural tube. It comes in a way to meet it by a refolding process of the ectoderm: it is, as you cannot fail to know, something which gives a good idea of the formation of a torus, since at a certain stage this neural tube remains open like a trumpet on two sides. On the contrary the formation of the cordal canal which is produced at the level of this Hensen's node, with a way of propagating itself laterally, gives the idea that there is produced here a process of interlacing, whose morphological aspect cannot fail to recall the structure of the projective plane, especially if one thinks that the process which is realised of this point called the Hensen node, is in a way a regressive process, according as development advances, it is in a line, in a posterior withdrawal of Hensen's node that there is completed this function of the primitive line, and that here there is produced this opening towards the front, towards the endoblast, of this canal which in sauropsidians presents itself as homologous, without being altogether identifiable to the neuro-enteric canal

that is found in the batrachia, namely what puts the terminal part of the digestive tube and the terminal part of the neural tube into communication, in short this point which is so highly significant because it joins the cloacal orifice, which is so important in analytic theory, to something which is found in front of the lowest part of the caudal formation to be what specifies the vertebrated and the prevertebrated more strongly than any other characteristic, namely the existence of the cord of which this primitive line and Hensen's node are the point of departure. There is here certainly a whole series of directions of research which, I believe, would deserve to retain our attention. In any case, if I have not in any way insisted on it, it is because it is certainly not in this direction that I want to engage myself. If I am speaking about it for the moment, it is both to awaken in you a little more interest about these structures which are so captivating in themselves and also to authenticate a remark which (6) was made to me about the fact that embryology would have its word to say here, at least by way of illustration.

This will immediately allow us to go further, on the function of this point.

A very close discussion on the plane of the formalism of these

topological constructions would only go on forever and would perhaps weary you. If the line that I trace here in the form of a sort of interlacing of fibres, is something whose function you already know in the cross-cap, what I want to point out to you is that the point which terminates it, of course, is a mathematical point, an abstract point. We cannot give it any dimension. Nevertheless we cannot think about it except as a cut to which we must give paradoxical properties, first of all from the fact that we can conceive it as punctiform. On the other hand it is irreducible. In other words, to be even able to conceive of the surface we cannot consider it as filled. It is a hole-point, as one might say. What is more, if we consider it as a hole-point, namely made up of the coupling of two edges, it would be

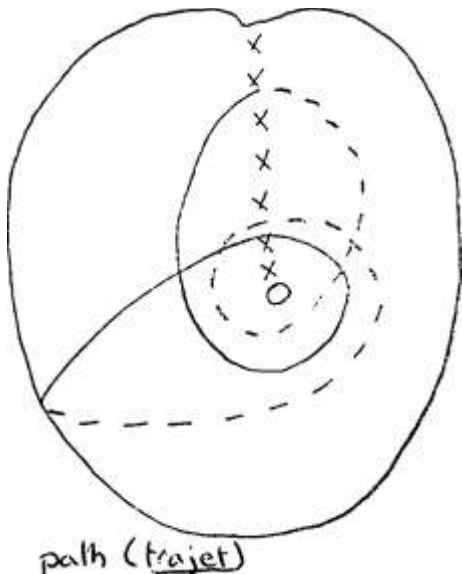

in a way indivisible in the direction that traverses it and one could in effect illustrate it by this type of single cut that one can make on the cross-cap; there are those which are made normally to explain the functioning of the surface in technical books which are consecrated to it - if there is a cut which passes through this point, how ought we to conceive of it? Is it in a way homologous and uniquely homologous to what happens when you make one of the lines above pass, traversing the structural line of false penetration, namely in a way if something exists that we can call a hole-point so that the cut, even

when it approaches it to the degree of being merged with this point, makes a circuit around this hole? This in effect is what (7) we must conceive because when we trace such a cut, here is

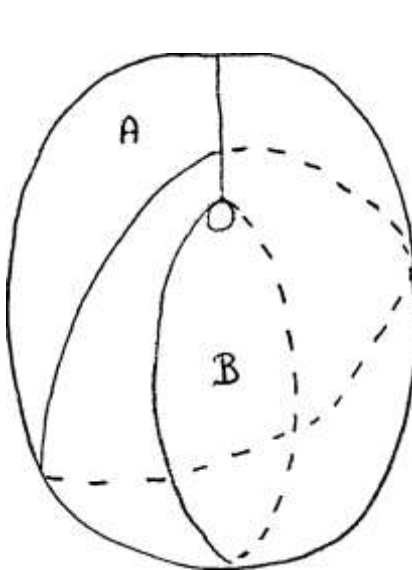

what we end up with: take if you wish, figure .., transform it into figure 3 and consider what is involved between the two ears which remain there at the level of A, and of 6 which would be behind. It is something which can again be put aside indefinitely to the point that the whole apparatus takes on this aspect, figure 5, these two parts of the figure representing the anterior and posterior folds that I drew on figure 4. Here at the centre, this surface which I drew in figure 4 appears here also in figure 5. It is here in effect, behind.

It remains that at this point something must be maintained which is in a way the initial stage of the mental fabrication of the

surface, namely with respect to this cut which is the one around which it is really constructed. Because it would be appropriate to conceive of this surface that you want to show, as a certain way of organising a hole, this hole whose edges are figured here. The initial stage is the point from which it is appropriate to start so that there can be made in a fashion which effectively constructs the surface in question, the edge-to-edge connections which are drawn here, namely that this edge here, after of course all the necessary modifications at its descent through the other surface, and this edge here comes to connect itself with the one that we have brought into this part of figure 4: a with a'. The other edge, on the contrary, must come to be connected, according to the general direction of the green arrow, with this edge there: d with d' is a connection which is only conceivable starting from the initial stage of something which signifies itself as the overlapping, as punctual as you would wish it to be, of this surface by itself at a point, namely of something which is here at a small point where it is split and where it has overlapped itself. It is around this that the process of construction takes place. If you do not have that, if you consider that the cut B that you have made here traverses the hole-point not by going around it as the other cuts with a circuit, but on the contrary by coming to cut it here in the way in which, in a torus, we can consider that a cut is produced (8) thus:

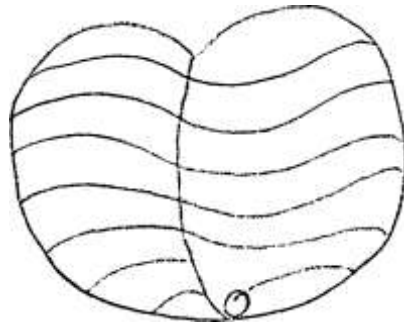

What does this figure become? It takes on another and quite different aspect. Here is what it becomes.



It becomes purely and simply the most simplified form of the folding back in front and behind of the surface figure 4, namely that what you have seen figure 4 organising according to a shape which comes to intersect itself edge by edge according to four segments, the segment a coming onto the segment a¹: this is a segment which would carry the number 1 with respect to another which would carry the number 3 with respect to the continuity of the cut drawn in this way; then a number 2 with segment number 4.

Here, the final figure, you have only two segments. They must be conceived of as being coupled to one another by a complete

inversion of one with respect to the other. It is very difficult to visualise. But the fact that what is on one side in one direction must be connected to what on the other side is in the opposite direction shows us here the pure structure, even though it is not visualisable, of the Möbius strip. The difference between what is produced when you carry out this simple cut on the projective plane and the projective plane itself, is that you lose one of the elements of its structure: you only make a pure and simple Möbius strip out of it, except that you see nowhere appearing what is essential in the structure of the Möbius strip: an edge. Now this edge is quite essential in the Möbius strip. In effect in the theory of surfaces - I cannot develop it in an entirely satisfying fashion - in order to determine properties such as the type, the number of connections, the characteristic, everything that is of interest in this topology, you ought to take into account that the Möbius strip has an edge and has only one, that it is constructed on a hole. It is not for the pleasure of the paradox that I say that surfaces are organisations of the hole. Here therefore, if it is a question (9) of a Möbius strip this signifies that, even though there is no way of representing it anywhere, it is necessary that the hole should remain. For it to be a Möbius strip you will put a hole here then, however small it may be. However punctual it may be, it will fulfill topologically exactly the same functions as that of the complete edge in this something that you can draw when you draw a Möbius strip, namely more or less something like the following:

As I pointed out to you a Möbius strip is as simple as that. A Möbius strip has only one edge. If you follow its edge you have gone right around everything that is edge on this strip and in fact it is only a hole, a thing which may appear as purely circular; by underlining the two sides, by inverting one with respect to the other coupling one, it will remain that it will be necessary in order for there to be question of a Möbius strip that we should preserve in as reduced a form as possible the existence of a hole. This indeed effectively is what indicates to us the irreducible character of the function of this point. And if we try to articulate it, to show its function we are led, by designating it as origin-point of the organisation of the surface on the projective plane, to rediscover in it properties which are not completely those of the edge of the

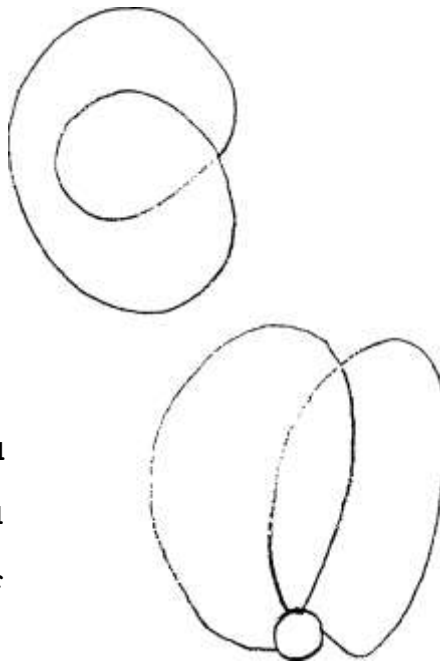

Möbius surface, but which are all the same something which is so much a hole that if one tries to suppress it by this operation of section by the cut passing through this point, it is in any case a hole that one makes appear in the most incontestable fashion.

What does that mean again? In order that this surface should function with its complete properties, and particularly that of being unilateral like the Möbius strip, namely that an infinitely (10) flat subject walking about on it, starting from some point or other, outside the surface, to return by an extremely short path and without having to pass through any edge to the reverse point of the surface from which he has started, in order that this can be produced, it is necessary that in the construction of the apparatus that we have called the projective plane there should be somewhere, however reduced you may suppose it to be, this sort of bottom which is represented here, this backside of the apparatus, there must remain a little piece however small it may be of the part which is not structured by interlacing otherwise the surface becomes something else and specifically no longer presents this property of functioning as unilateral.

Another way of highlighting the function of this point: the cross-cap cannot be drawn purely and simply as something which could be divided in two by a line where the two surfaces are supposed to intersect. It is necessary that there should remain here something which beyond the point surrounds it, something like a circumference, however reduced it may be, a surface that allows there to be put into communication the two upper lobes, as one might say, of the surface structured in this way. It is this that shows us the paradoxical and organising function of the point.

But what this allows us to articulate now, is that this point is made by the coupling of two edges of a cut, a cut which cannot itself be retraversed in any way, be divided, a cut which you see here in the way that I have imaged it for you, as deduced from the structure of the surface and which is such that one can say that if we were to define arbitrarily something as inside and as outside - by putting for example in blue on the drawing what is inside and in red what is outside - at one of the edges of this point the other would present itself in this way since it is made from a cut, however minimal you may suppose it to be, of the surface which has been superimposed on the other. In this privileged cut what will be confronted without being connected will be an outside with an inside, an inside with an outside.

—————	inside
- - - - -	outside
—————	inside
- - - - -	outside

Such are the properties that I present to you - one could express this in a more learned, more formalist, more dialectical way - in (11) a form which appears to me not alone sufficient, but necessary in order to be able subsequently to image the function that I intend to give it for our use.

I pointed out to you that the double cut is the first form of cut which introduces into the surface defined as the cross-cap of the projective plane the first cut, the minimal cut which obtains the division of this surface. I indicated to you the last time what this division culminated in and what it signifies. I showed you in these very precise figures all of which I hope you have noted, and which consisted in proving to you that this division has precisely as a result to divide the surface in 1, a Mobius surface namely a unilateral surface of the type of the figure here: [Missing in text]

This preserves, as one might say, in itself only a part of the properties of the surface called the cross-cap, and, precisely this particularly interesting and expressive part which consists in the unilateral property; and in the one which I always highlighted for you when I had circulated among you these little Mobius ribbons that I made, namely that it is a question of a left surface, which is, we will say in our language, specularisable, that its image in the mirror cannot be superimposed on it, that it is structured by a fundamental asymmetry. And the whole interest of this structure that I am showing you is that, on the contrary, the central part, what we will call the central piece, isolated by the double cut, while

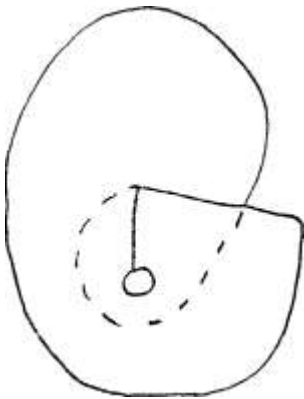

being manifestly the one which carries with it the veritable structure of the whole apparatus called the cross-cap, it is enough to look at it, I would say to see it, it is enough to imagine that, in some fashion or other the edges here are joined to one another in the points of correspondence that they present visually in order that there should be immediately reconstituted the general shape of this projective plane or cross-cap.

But what appears with this cut is a surface which has this

aspect

that you can, I think, now consider as something which, for you, (12) has gained enough familiarity for you to project it into space, this surface which traverses itself according to a certain line which stops at a point. It is this line and it is above all this point which gives to the double circuit shape of this cut its privileged signification from the schematic point of view because it is this that we going to trust to give ourselves a schematic schema of representation of the relationship \$ cut of o, which we will not manage to grasp at the level of the structure of the torus namely of something which allows us to articulate schematically the structure of desire, the structure of desire in so far as we have already inscribed it formally in this something which we are saying allows us to conceive of the

structure of the phantasy \$ cut of o. S\$ o

We will not exhaust this subject today, but I will try to introduce today for you the fact that this figure, in its schematic function, is rather exemplary in order to allow us to find the relationship of \$ cut of o, the formalisation of the phantasy in its relationship with something which is inscribed in what is the remainder of the surface called the projective plane or cross-cap when the central piece is in a way enucleated. It is a question of a specularisable, fundamentally asymmetrical structure which is going to allow us to localise the field of this asymmetry of the subject with respect to the Other, especially concerning the essential function that the specular image plays in it.

Here in fact is what is in question: the true imaginary function, as one might say, in so far as it intervenes at the level of desire, is a privileged relationship with o, object of desire, term of the phantasy. I say term because there are two of them, \$ and o, linked by the function of the cut. The function of the object of the phantasy, in so far as it is the term of the function of desire, this function is hidden.

What is most efficient, most efficacious in the relationship to the object, as we understand it, is marked by a maximal veiling in the vocabulary currently accepted in psychoanalysis. One could say that the libidinal structure, in so far as it is marked by the narcissistic function, is what covers and masks the relationship to the object for us. It is in so far as the narcissistic, secondarily narcissistic, relationship, the relationship to the image of the body as such is linked by something structural to this relationship to the object which is that of the fundamental phantasy, that it takes on all its weight, but this something structural of which I speak is a (13) complementary relationship, it is in so far as the relationship of the subject marked by the unary trait finds a certain support which is a lure, which is an error, in the image of the body as constitutive of specular identification that it has its indirect relationship with what is hidden behind it, namely the relationship to the object, the relationship to the fundamental phantasy. There are therefore two imaginaries, the true and the false; and the false is only sustained in this sort of subsistence to which there remain attached all the mirages of the mé-connaître (miscognition) - I already introduced this play on words, mé-connaissance: the subject miscognises himself in the mirror relationship. This mirror relationship in order to be understood as such, ought to be situated on a basis of this relationship to the Other which is the foundation of the subject, as long as our subject is the subject of discourse, the subject of language. It is by situating what \$ cut of o is with respect to the fundamental deficiency of the Other as locus of the word, with respect to what is the only definitive response at the level of enunciating, the signifier of (;J, of the universal witness in so far as it is lacking and that at a given moment it only has the function of a false witness, it is by situating the function of o at this point of failure, by showing the support that the

subject finds in this o which is what we aim at in analysis as an object which has nothing in common with the object of classical idealism, which has nothing in common with the object of the Hegelian subject.

It is by articulating in the most precise fashion this o at the point of lack of the Other, which is also the point where the subject receives from this Other, as locus of the word, its major mark, that of the unary trait, the one which distinguishes our subject from the knowing transparency of classical thinking as a subject entirely attached to the signifier in so far as this signifier is the turning point of his rejection, for him the subject, of the whole signifying realisation ... it is in showing, starting from the formula o as structure of the phantasy, the relationship between this object and the lack of the Other that we see how at a moment everything retreats, everything is effaced in the signifying function in face of the rise, the eruption of this object. It is towards this that we can advance even though it is the most veiled, the most difficult zone to articulate in our experience. Because precisely we have a check for it in the fact that by the ways which are those of our experience, paths that we take, most usually those of the neurotic, we have a structure which it is not at all a matter (14) of loading onto scapegoats. At this level, the neurotic like the pervert, like the psychotic himself, are only faces of the normal structure. I am often told after these lectures: when you speak about the neurotic and about his object which is the demand of the Other, unless his demand is the object of the Other, why do you not speak to us about normal desire! But precisely, I am talking about it all the time. The neurotic, is the normal in so far as, for him, the Other with a big O , is all-important. The pervert, is the normal in so far as for him the Phallus - the big ≤ 5 that we are going to identify with this point which gives to the central piece of the projective plane all its consistency - the Phallus is all-important. For the psychotic his own body, which is to be distinguished in its place, in this structuring of desire, his own body is all-important.

And these are only faces where something is manifested about this element of paradox which is the one which I am going to try to articulate before you at the level of desire.

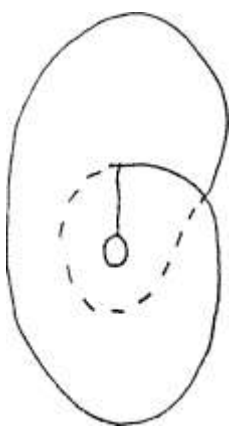

Already, the last time, I gave you a foretaste of it by showing you what can be distinct in the function, in so far as it emerges, of the phantasy, namely of something that the subject foments, tries to produce at the blind place, at the masked place which is the one this central piece gives the schema of. Already in connection with the neurotic and precisely the obsessional, I indicated to you how it can be

conceived that the search for the object might be the true aim, in the obsessional phantasy, of this always renewed and always impotent attempt at destroying the specular image in so far as it is what the obsessional aims at, that he senses as an obstacle for the realisation of his fundamental phantasy. I showed you that this clarifies very well what happens at the level not of the sadistic phantasy but the Sadian one, namely the one that I had occasion to spell out previously, for you, with you, in the seminar on ethics, in so far as, being the realisation of an inner experience that one cannot entirely reduce to the contingencies of the knowable framework of an effort of thinking concerning the relationship of the subject to nature, it is by insulting nature that Sade tries to define the essence of human desire. And it is through this indeed that, today already, I can (15) introduce for you the dialectic involved. If somewhere we can still preserve the notion of knowledge, it is undoubtedly outside the human field. There is no obstacle to us thinking, we positivists, Marxists, anything you wish, that nature knows herself. She undoubtedly has her preferences. She does not take, for her part, just any materials whatsoever. This indeed is what has left the field open to us for some time, to find a whole load of other funny ones that she had funnily left to one side!

However she may know herself, we do not see anything to prevent it. It is quite certain that the whole development of science, in all its branches, is constructed for us in a fashion which renders more and more clear the notion of knowledge. Connaturality with whatever means there may be in the natural field, is what is most foreign, always more foreign to the development of this science. Is it not this that makes it so contemporary for us to advance into the structure of desire as our experience precisely, effectively makes us sense it everyday? The kernel of unconscious desire and what one might call its orienting, attracting, relationship, is absolutely central with respect to all the paradoxes of human miscognition. And does its foundation not depend on the fact that human desire is an acosmic function?

That is why, when I try to foment these plastics for you, you might think you are seeing an updating of ancient imaginary techniques which are the ones that I taught you to read in the form of Plato's sphere. You might say that to yourselves. This little double point, this stamp shows us that here is the field where there is ringed what is the veritable mainspring of the relationship between the possible and the real. What gives to classical logic all its charm, all its long-pursued seduction, the real point of interest of formal logic - I mean that of Aristotle - is what it supposes and what it excludes and what is really its pivotal point, namely the point of the impossible in so far as it is that of desire. And I will come back to it. Therefore you can say that everything that I am in the process of explaining to you here is the continuation of the preceding discourse. They are - let me use this formula - Theo-type contraptions. Because when all is said and done, it is as well to give a name to this God with whom we gargle a little bit too

romantically our throats in this proclamation that we have done very well in saying that God is dead. There is god and god. I already told you that some of them are quite real. We would be (16) wrong to overlook the reality. The God who is involved, the problem of whom we cannot elude since it is a problem which is our business, a problem in which we have to take part, this one, in order to distinguish terms, echoing Beckett who one day called him Godot, why not have called him by his true name, the supreme Being? If I remember rightly moreover, the good friend of Robespierre had this name as a proper name, I believe that she was called Catherine Theot. It is quite certain that a whole part of analytic elucidation and, in a word, the whole story of the father in Freud, is our essential contribution to the function of Theo in a certain field, very precisely in this field which finds its limits at the edge of the double cut in so far as it is what determines the structuring characteristics, the fundamental kernel of phantasy in theory as in practice. If something can be articulated which puts in the balance the domains of Theo, which prove not to be so totally reduced, nor reducible since we busy ourselves with them just as much, except for the fact that, for some time, we are losing, as I might say, their soul, their sap and their essence. One no longer knows very well what to say. This father seems to be reabsorbed in a cloud that is more and more withdrawn and at the same time leaves the import of our practice singularly in suspense. It is not at all superfluous for us to evoke that there is here in effect some historical correlative when it is a matter of defining what we have to deal with in our domain. I believe it is time. It is time because, already in a thousand concretised, articulated, clinical and practical forms a certain sector is being separated out in the evolution of our practice, which is distinct from the relationship to the Other, 0, as fundamental, as structuring the whole experience whose foundations we have found in the unconscious. But its other pole has all the value that I earlier called complementary, the one without which we wander, I mean without which we return, as a retreat, an abdication, to this something which was the ethics of the theological era, the one whose origins I made you sense as certainly conserving their whole price, all their value in this original freshness that Plato's dialogues preserves them in. What do we see after Plato, if not the promotion of something which is now perpetuated in the dust-covered shape of this distinction regarding which it is really scandalous that one can still find it written by an analyst, between ego-subject and ego-object! Speak to me about the rider and the horse, of the dialogue between the soul and desire, but precisely it is a matter of this soul and of this desire, of the referring back of desire to the soul at the moment precisely when only desire was in question, in short, everything that I showed you last year in Transference. It is a matter of (17) seeing this more essential clarity that we for our part can contribute to it: the fact is that desire is not on one side. If it appears to be this unmanageable thing that Plato describes in such a pathetic, moving fashion and that the superior soul is destined to dominate, to captivate, of course, it is because there is a relationship, but the relationship is internal, and to divide it, is precisely to surrender oneself to a lure, to a lure

which depends on the fact that this image of the soul which is nothing other than the central image of secondary narcissism as I defined it for you earlier and to which I will return, only functions as a way of access, a deceptive access path, but an access path oriented as such to desire. It is certain that Plato was not ignorant of it. And what renders his enterprise all the more strangely perverse, it is that he masks it from us. Because I will speak to you about the phallus in its double function, the one which allows us to see it as the common point of eversion as I might say, of evergence, if I may put forward this word constructed as the reverse of convergence; if I think I can articulate for you on the one hand the function of this phallus

at the level of the \$ of the phantasy and at the level of o that it authenticates for desire, from today I will indicate to you the kinship of paradoxes with this very image that this



because here $\overline{\quad}^J$ schema of the figure gives
 | nothing other than this point
 guarantees
 Q , | for this surface cut in this
 way its

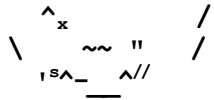

character as a unilateral surface, but entirely guarantees it to it, making truly of \$ the cut of o.

But let us not go too quickly, o, for its part, undoubtedly is the cut of f. The sort of reality that we are aiming at in this objectality or this objectiveness that we alone define, is truly for us what unifies the subject. And what have we seen in the dialogue between Socrates and Alcibiades? And what is this comparison between this man carried to the pinnacle of passionate homage and a box: this marvellous box, as always, has always existed wherever man has known how to construct for himself objects, figures of what for him is the central object, that of the fundamental phantasy, it contains what, Alcibiades says to Socrates? The agalma. Let us begin to see what this agalma is: something which should have not just a tiny relationship with this central point which gives its accent, its dignity to the object o. But things, in fact are to be inverted at the level of the object. This phallus, if it is established so paradoxically (18) that it is always necessary to pay great attention to what is its enveloping function and its enveloped function, I believe that it is rather at the heart of the agalma that Alcibiades seeks what he is appealing to, at this moment when the Symposium ends, in this something which we alone are able to read, even though it is obvious, because what he is looking for, what he prostrates himself before, what he makes this impudent appeal to is what? Socrates as desiring, whose avowal he wants. At the heart of the agalma what he is searching for in the object manifests itself as being the pure eron, because what he wants is not to tell us that Socrates is lovable, it is to tell us that what he desired most in the world was to see Socrates desiring. This most radical subjective implication at the heart of the object itself of desire where I think that all the same you find your bearings a little, simply because you could put it back into the old drawer of the desire of man and the desire of the Other. It is something that we are going to be able to highlight more

precisely. We see that what organises it is the punctual, central function of the phallus. And there, we have our old enchanter rotting or not, but certainly an enchanter, the one who knows something about desire, who sends off our Alcibiades on his way telling him what? To look after his soul, his ego, to become what he is not: a neurotic for the centuries to come, a child of Theo.

And why? What is this reply of Socrates to a being as admirable as Alcibiades? In that it is manifestly he who is it, the agalma, as I think I have manifested before you, it is purely and manifestly only Alcibiades who is the phallus. Only nobody can know whose phallus he is. To be phallus in that state, one must be made of the right stuff. Undoubtedly he has what it takes and the charms of Socrates have without any doubt no hold on Alcibiades. He passes in the centuries of ethical theology which followed towards this enigmatic and closed form, but that the Symposium nevertheless indicates for us the starting point with all the necessary complements, namely that Alcibiades, manifesting his appeal for a desirer at the heart of the privileged object, does nothing other than appear in a position of frantic seduction with respect to the one whom I called the fundamental idiot, whom as the supreme irony Plato connoted by the proper name of goodness itself: Agathon - the supreme good has no other name in his dialectic. Is there not here something which sufficiently shows that there is nothing new in our research? It returns to the beginning, in order this time to understand what has happened since.

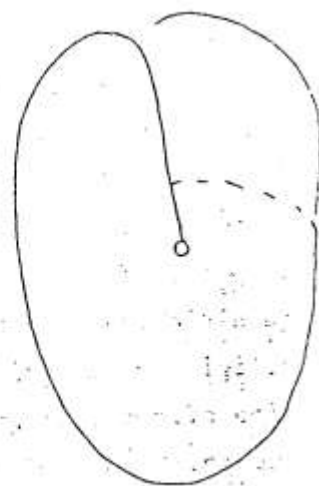
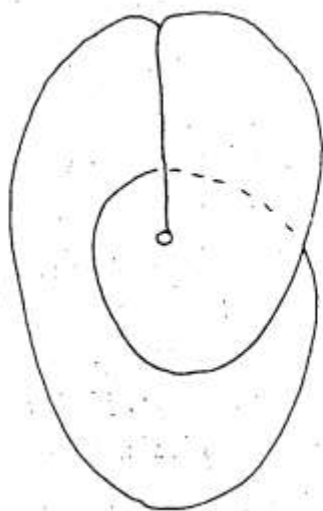
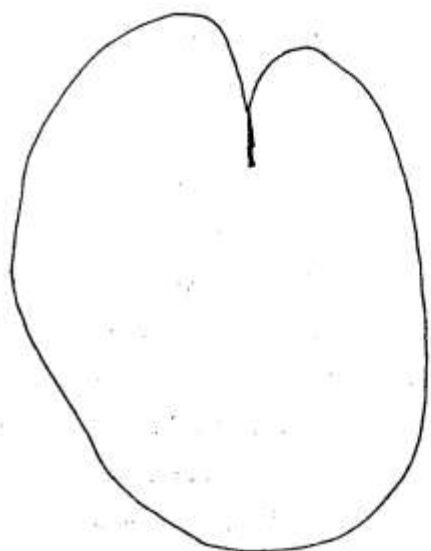
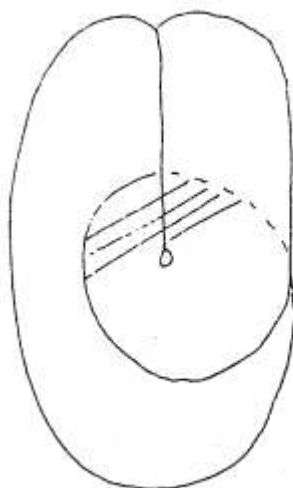
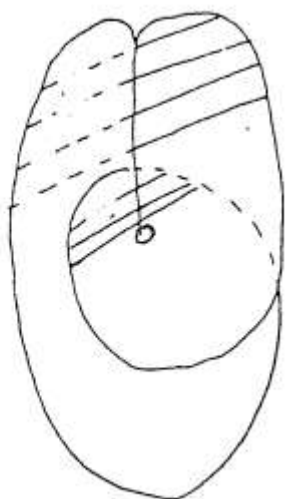
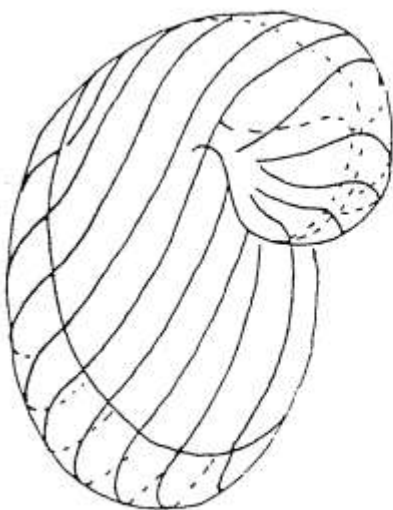
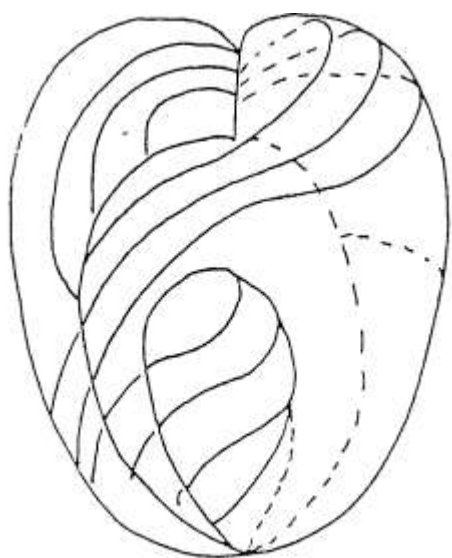

Wednesday 20 June 1962

The time for the end of this year is approaching. My discourse on identification has not of course been able to exhaust its field. Moreover I do not think I should experience any feeling of having failed you on that account.

This field in effect, someone at the beginning was a bit uneasy, not without reason, that I should have chosen a thematic which seemed to him would allow it to be the instrument for us of "everything is in everything"; I tried on the contrary to show you the structural rigour attached to it.

I did this starting from the second mode of identification distinguished by Freud, the one that I believe without false modesty to have henceforth rendered unthinkable for you except under the mode of the functioning of the unary trait. The field I have been on since I introduced the signifier of the interior eight is the one of the third mode of identification, this identification where the subject is constituted as desire and in which all our previous discourse prevented us from overlooking that the field of desire is only conceivable for man starting from the function of the big Other: the desire of man is situated at the locus (2) of the Other and is constituted precisely as this mode of original identification that Freud teaches us to separate out empirically - which does not mean that his thinking on this point is empirical - in the form of what is given in our clinical experience, most especially in connection with this so manifest form of the constitution of desire which is that of the hysteric.

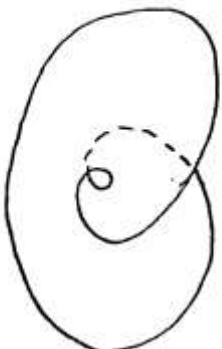
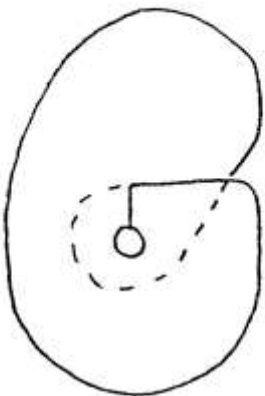
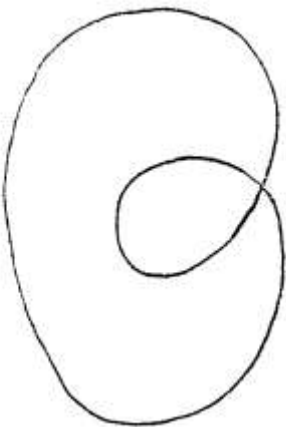

To be content to say: there is the ideal identification and then there is the identification of desire to desire can suffice of course for a first clarification of things. As you can see clearly, Freud's text does not leave things there, and does not leave things there in so far as already within the major works of his third topography, he shows us the relationship of the object, which here can only be the object of desire, to the constitution of the ideal itself. He shows it on the plane of collective identification, of what is in short a sort of confluence of experience, through which the unarity of the trait, as I might say, my unary trait - this is what I wanted to say - is reflected in the unicity of the model taken as the one which functions in the constitution of this order of collective reality that is, as one might say, the crowd with a head, the leader.

This problem, however local it may be, is indeed no doubt the one which offered to Freud himself the best terrain to grasp, at the point that he was elaborating these things at the level of the third topography, something which for him, not in a structural fashion, but in a way linked to a sort of concrete point of confluence, collected together the three forms of identification. Since moreover, the first form, the one which will remain in short at the edge, at the end of our development this year, the one which is put as the first, the most mysterious also, even though apparently the first brought to light in analytic dialectic, the identification to the father, is here in this model of identification to the leader, to the crowd, and is here in a way implicated without being completely implicated, without (3) being at all included in its total dimension, in its entire dimension.

The identification to the father brings into question in effect something of which one can say that linked to the tradition of a properly historical adventure to the point that we can probably identify it to history itself, opens up a field which we have not even dreamt this year of bringing into our field of interest, for fear of being really completely absorbed in it.

To take at first as object the first form of identification would have been to engage our whole discourse on identification in the problems of Totem and taboo, the work which for Freud was, one could well say, what one could call die Sache selbst, the thing itself, and of which one can also say that it will remain so in the Hegelian sense, namely in so far as for Hegel die Sache selbst, the work, is in short everything which justifies, everything by which there merits to subsist this subject who never existed, who never lived, who never suffered, what matter, simply this essential extériorisation of a work, with a path traced by him. This indeed, in effect, is what one looks at and what it simply wants to remain, a phenomenon of consciousness in movement, and from that angle, one could say in effect that

we are right, that we would be wrong, not to identify the legacy of Freud, if it had to be limited to his writings, to Totem and taboo.

Because the discourse on identification that I pursued this year, with what it constituted as an operational apparatus - I am sure that you are only at the point of beginning to put it to use - you cannot yet before testing it appreciate its importance which cannot but be altogether decisive as regards everything that calls at the present time for an urgent formulation, in the first place phantasy.

I wanted to mark that it was the essential preliminary step, demanding absolutely a properly didactic preliminary history in order that there could be appropriately articulated the weakness, the fault, the loss that we are at to be able to refer with the slightest appropriateness to what is involved concerning the paternal function.

I am very precisely alluding to something which we could qualify as the soul of the year 1962, during which there appeared two (4) books by Claude Lévi-Strauss, Le Totémisme and La Pensée sauvage. I believe that not a single analyst read them without at once feeling himself - for those who follow the teaching here - fortified, reassured, and without finding in them the complement - because of course he had the leisure to explore fields that I can only bring in here by allusion, to show you the radical character of the signifying constitution in everything that belongs, let us say, to culture, even though, of course he underlines it, this is not to demarcate a domain whose frontier is absolute. But at the same time, within his very pertinent exhaustions of the classificatory mode, of which one could say that La pensée sauvage is less the instrument than in a way the effect, the function of Totem and Taboo appears entirely reduced to these signifying oppositions.

Now it is clear that this could not be resolved except in an impenetrable fashion, if we analysts are not capable of introducing here something which is at the same level as this discourse, namely, like this discourse, a logic.

It is this logic of desire, this logic of the object of desire whose instrument I have given you this year, by designating the apparatus through which we can grasp something which, to be worthwhile, cannot but have been for all time the veritable animating force of logic, I mean there where, in history in the history of its progress, it made itself felt as something which opened out to thinking. It nevertheless remains that this secret mainspring remained masked perhaps, because logic for its part did not involve, did not imply the movement of this world which is not nothing: it is called the world of thought, in a certain direction which, even though it was centrifugal, was nonetheless all the same determined by something which referred itself to a certain type of object which is the one that we are interested in for the moment.

What I defined the last time as the point, the point $\langle p$ in a certain new way of delimiting the circle of connotation of the object, is what puts us on the threshold, before parting this year, of having to pose the function of this ambiguous $\langle p$ -point, as I told you, not just simply in the mediation but in the constitution inherent to one and the other, not simply as the reverse which would be worth as much as the front (l'envers ... l'endroit) but as a reverse, I told you, which would be the same thing as the front, of the $\$$ barred and of the point o in the phantasy, in recognising what the object of human desire is, (5) starting from desire, in recognising the reason why in desire the subject is nothing other than the cut of this object.

And how individual history - this discoursing subject in which this individual is only included - is orientated, pivoting, polarised by this secret and perhaps in the final analysis, never accessible point, if there must be admitted with Freud for a time at least in the irreducibility of a Urverdrangung the existence of this navel of desire in the dream of which he speaks in the Traumdeutung, it is this whose function we cannot omit in any appreciation of the terms into which we decompose the faces of this nuclear phenomenon.

That is why, before rejoining clinical experience, always too easy to put us back into the rut of truths to which we accommodate ourselves very well in a veiled state, namely: what is the object of desire for the neurotic, or again for the pervert, or again for the psychotic? It is not that, this sampling, this diversity of suits which will never do anything except make us lose the interesting cards. "Become what you are", says the formula of classical tradition. It is possible. A pious wish. What is guaranteed, is that you become what you miscognise (meconnaitre). The way in which the subject miscognises the terms, the elements and the functions between which are played out the fate of desire, in so far precisely as there appears to him somewhere in an unveiled form one of these terms, is the way that each one of those whom we have named neurotic, perverse and psychotic is normal. The psychotic is normal in his psychosis, and moreover because the psychotic in desire has to deal with the body; the pervert is normal in his perversion because he has to deal with the phallus in its variety and the neurotic because he has to deal with the Other, the big Other as such. They are normal because these are the three normal terms of the constitution of desire.

These three terms are of course always present. For the moment, it is not a matter of their being in any one of the these subjects, but here in the theory. This is why I cannot advance in a straight line. It is because there comes to me at every step the need to make the point with you again, not so much because I am so worried that you should understand me "Are you all that keen to be understood?", I am asked from time to time, these are the kind remarks that I hear in my analyses. Obviously, yes. But what creates the difficulty, is the (6) necessity of making you see that you are included in this discourse; it is starting from there that it can be deceiving,

because you are included in it in any case; and errors can arise uniquely from the way in which you conceive that you are included in it.

I was very struck to read, yesterday morning, before the electricity strike started, the work of one of my students on phantasy. Not bad, by God. Of course, it is not yet the putting into action of the apparatuses of which I spoke, but the simple collation of passages in Freud where he speaks about phantasy in an absolutely inspired fashion. When one asks oneself what relevance, in the absence of everything that can be said, these initiatives have conditioned since, how the first formulation was able to find this relevance and remain in a way marked now by the very stamp which is the one that I am trying to isolate from things. This drive which makes itself felt from within the body, these schemas entirely structured from these topological prevalencies, it is only on this that there is agreement.

How define what functions from the arrival of the outside and from the arrival of the inside?

What incredible vocation to platitude was required in what one could call the mentality of the analytic community to believe that this is a reference to what is called "the biological agency"! Not that I am in the process of saying that a body, a living body, - I am not joking - is not a biological reality, only to make it function in the Freudian topology as topology and to see in it some biologism or other which is supposed to be radical, inaugural, co-extensive with the function of drive, is what gives here the whole breadth, the whole gap of what is called a misinterpretation, a misinterpretation absolutely manifest in the facts, namely that as there is no need to point out, until we hear differently, namely the revision that we await in biology, there has not been the trace of a biological or even physiological, nor even esthesiological discovery made through analysis (esthesiological means a sensorial discovery, something new that one might have been discovered in the way of sensing things); what constitutes the misinterpretation, can be defined very clearly, it is that the relationship of the drive to the body is everywhere marked in Freud; topologically, this does not have the same reference value, the idea of a direction, as a discovery in biological research.

(7) It is quite certain that this "what is a body", as you know, was not even an idea outlined in the consensus of the philosophising world at the time that Freud outlined his first topography; the whole later notion of Dasein is constructed to give us as I might say the primitive idea that one could have of what a body is, as a constituting there, as certain dimensions of presence - and I am not going to re-do Heidegger for you, because if I speak to you about him, it is because you are soon going to have this text which I told you was easy, you will have his own words. In any case the facility with which we read him now proves well that what he has launched into the current of things is well and truly in circulation; these dimensions of presence however they are described, the Mitsein, this being there and all

the rest, in der Welt sein, all the so different and so distinct mundanities; because it is a matter precisely of distinguishing them from space: latum, longum et profundum, which has no trouble showing us that this is only the abstraction of the object and because moreover this is proposed as such in this Descartes whom I put this year at the beginning of our account: the abstraction of the object as subsisting, namely already ordered in a world which is not simply a world of coherence, of consistency, but enucleated of the object of desire as such.

Yes, in Heidegger, all of this makes admirable irruptions into our mental world. Let me tell you that if there are people who should not in any way be satisfied with it, it is psychoanalysts, it is I. This no doubt suggestive reference to what I will call - you should not see in it any kind of attempt to belittle what is involved - an artisanal praxis, the foundation of the tool-object, as discovering undoubtedly at the highest level these first so subtly picked out dimensions of presence which are proximity, distancing, as constituting the first lineaments of this world; Heidegger owes a lot - he told me so himself - to the fact that his father was a cooper.

All this reveals to us something with which presence is concerned in a pre-eminent way and to which we would hold onto much more passionately by posing the question of what every instrument has in common: the primitive spoon, the first way of digging, of taking something out of the current of things, what does this have to do with the instrument of the signifier? But when all is said and done is everything not decentred for us from the beginning?

(8) If what Freud contributed has a meaning, namely that at the heart of the constitution of every object there is the libido, if this has a meaning, this means that the libido is not simply the surplus of our praxic presence in the world, which is the age-old thematic and the one that Heidegger re-introduces: because if Sorge is care, occupation is what characterises this presence of man in the world, that means that when care relaxes a little people start fucking. Which, as you know, is the teaching for example of someone whom I choose here really, without any scruple and in a polemical spirit, because he is a friend: Mr Alexander. Mr Alexander has moreover his very honourable place in this simply cacophonous chorus that one can call theoretical discussion in the American Psychoanalytic Society, he has his place by full right, because it is obvious that it would be a little extreme to allow themselves, in a society as large and officially established as this American association, to reject what really coincides moreover with the ideals, with the practices, of what is called a particular cultural space.

But it is clear that even to outline a theory of libidinal functioning as being constituted by the surplus part of a certain energy however we may categorise it - survival energy or other - is actually to deny the whole value, not simply the poetic one, but the raison d'etre of our function as therapists, as we define its terms and its goals.

That on the whole practically we adjust ourselves very well, we do our business (affaire) by bringing people back to theirs - affairs of course - only what is certain is that all the same when we pinpoint this result under the form of therapeutic success, we know at least this: it is either one thing or the other: either we have achieved it outside any kind of properly analytic path, and in that case what was amiss at the heart of the affair - because this is what is in question - is still amiss, or indeed if we have got to that, it is precisely in the whole measure - which is only the a-b-c of what we are taught - that we have not tried in any way to settle the affair, but we have been elsewhere, around what was amiss, what was happening at the centre, the libidinal knot.

It is for this reason that results that can be sanctioned in the (9) sense of adaptation - I apologise, I am making a little detour here through banalities, but there are banalities that must all the same be recalled, especially because after all, recalled in a certain fashion banalities may sometimes appear to have little banal about them - any therapeutic success, namely to lead people to the well-being of their Sorge, of their "little affairs" is always for us more or less, at bottom we know it, this is why we have no reason to boast about it - a last resort, an alibi, a misappropriation of funds, if I can express myself thus.

In fact, what is still much more serious, is that we prohibit ourselves from doing better, knowing full well that this action of ours of which we may boast from time to time as if it were a success, is carried out along paths which do not concern the result. Thanks to these paths, we bring about some modifications in a complementary place which is of no concern to them except by reverberation; it is the most that one can say. When do we manage to replace a subject in his desire? It is a question that I pose to those who here have some experience as analysts, obviously not to the others.

Is it conceivable that an analysis should result in making a subject enter into desire, as one speaks about entering into a trance, into rut or into religion? It is indeed for this reason that I allow myself to pose the question at a local point; the only one when all is said and done which is decisive, because we are not apostles, is whether this question does not deserve to be preserved when analysts are involved; because for the others, the problem posed is: what is desire for it to be able to subsist, to persist in this paradoxical position. Because after all it is quite clear that I am not in any way expressing a wish by this that the effect of analysis should go to rejoin the one filled from all ages by mystical sects whose famous, no doubt deceiving, often doubtful operations in any case most of the time, are not what I would especially ask you to interest yourselves in, except all the same in order to situate them as occupying this global place of leading the subject onto a field which is none other than the field of his desire.

And in a word, spending my last weekend in a series of rebounds,

trying to see the meaning of some words of Muslim mystical technique I opened some things that I worked on at one time, like everybody else. Who has not looked a little at these indigestible and deadening books on Hinduism, on philosophy, (10) about some ascesis or other, which are presented to us in a dust-laden and in general misunderstood terminology, I would say all the better understood when the transcriber is more stupid, this is why the English works are the best; above all I would ask you not to read the German works, they are so intelligent that it is immediately transformed into Schopenhauer. And then, there is Rene Guénon, of whom I speak because he is a curious geometrical place. I see from the number of smiles, the proportion of sinners! ... I swear that at any moment, at the beginning of this century of which I am a part - I do not know if it is still going on, but I see that this name is not unknown, so it must ^ still be going on - the whole of French diplomacy found in Rene Guénon, this imbecile, its maltre á penser. You see the result! It is impossible to open one of his works without really finding nothing to do with it because what he says the whole time, is that he ought to shut up.... This has a probably unextinguishable charm; because the result is that thanks to this all sorts of people who probably did not have a lot to do - as Briand said: "You know that we have no foreign policy, because a diplomat must be in an atmosphere that is a little unbreathable....!" - well, this has helped them to remain in their little carapace.

In short, all this is not intended to direct you towards Hinduism, but all the same, because I find myself I cannot say "rereading", because I never read them, Hindu texts, and as I tell you, it is always very disappointing from the beginning, but I have seen retranscribed, reassembled much more accessible things about Muslim mystical technique, by someone marvellously intelligent, although presenting all the appearances of madness, who is called M Louis Massignon - I say "the appearances" - and referring himself to boudhi; in connection with the elucidation of these terms, the point that he highlights about the term function - I mean that it is the second-last threshold to be crossed before the liberation sought for, before Hindu ascesis - the function that he gives to the boudhi, as the object - because that is what this means, which of course is nowhere written down, except in this text of Massignon, where he finds its equivalent in the man-sou (?) of Shiite mysticism - the function of the object as being the indispensable turning point of this concentration in order to come to the metaphorical terms of the subjective realisation that is in question, which when all is said and done is only the access to this field of desire that we (11) can call simply the desirer. And what is this desirer?

It is quite sure that those who have not gone there at all know nothing about it and this indeed is what annoys those who officiate in the already well-constituted domain which I called the last time that of Theo, quite naturally suspicion, exclusion, the smell of sulphur with which mystical ascesis is surrounded in all religions.

In any case, the relationship articulated at this stage, at the

stage that one can describe as the completion of the involution, of the assumption of the subject into an object chosen moreover by mystical techniques in a very arbitrary order - it can be a woman - it can be a cork in a bottle - appeared to me to coincide perfectly with the formula:

$$\begin{array}{c} \$ \\ \frac{o}{\text{cut of}} \end{array}$$

as I formulate it for you as given, as the most simple formulization that we are allowed to reach in contact with the different forms of clinical work, namely that it is necessary to presume that the structure of this central point as we are able to construct it - the term is from Freud - and as we ought necessarily to construct it to account for the ambiguities of its effects.

The work to which I alluded earlier, that I read yesterday morning, applied itself to taking up again - it is necessary for things to be digested - a field that I had treated a long time ago, namely the structure of the Wolfman, especially in the light of the structure of the phantasy; the thing is very well circumscribed in this work. Nevertheless, compared to the first formulations, those I constructed before bringing you the recent instruments, it does not mark much of an advance, but it designates for me the point at which after all you follow what I may show you here as a locus to be superseded.

Let us take it up therefore simply to highlight it - it is not a critique - this work, there would be many others to do and you should know what should be broadcast, what I would find suitable - the logical definition of the object that I will allow myself to call Lacanian on this occasion because it is not the same thing as speaking about the execrated lacanism of the object of desire; the logical function of this

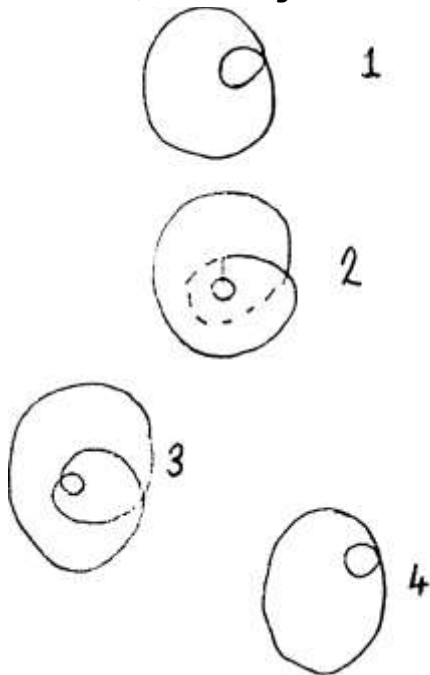

object does not depend - this is what is designated by the novelty of the little circle (1) which I teach you to circumscribe by telling you that it is essentially constituted by the presence of this point which is here, either in its central field, or at the limit of this field, namely here, because these three cases 2 - 3 - 4, are the same as the final reduction of the field - its logical function does not depend either on its extension or on its comprehension; for its extension, if one can designate something by this term, depends on the structuring function of the point. The more this field is as I might say, punctual (4), the more effects there are and these effects are, as one might say, ones of inversion. In the light of this principle, there is no problem about what Freud provided us with as a reproduction of the Wolfman's phantasy.

You know this tree, this big tree and the wolves which are absolutely not wolves, there are five of them perched on this tree whereas elsewhere there is talk of seven of them.

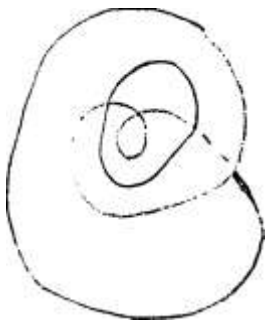

If we had need of an exemplary image of what little o is here, at the limit of field (3) when its phallic radicality is manifested by a sort of singularity as accessible there where alone it can appear to us, namely when it approaches or when it may approach the outside field, (4) the field of what can be reflected, the field of that in which asymmetry may allow the specular error,

we have it here. Because it is clear at the same time that it is not of course the specular image of the Wolfman which is there before him, and that nevertheless - we have marked it moreover for a long enough time for this not to be a novelty - for the author of the work I am speaking about, it is the very image of that moment that the subject experiences as the primal scene. I mean that it is the very structure of the subject in front of this scene. I mean that before this scene, the subject makes himself into a wolf looking and makes himself into five wolves looking. What opens out suddenly to him from that night on, is (13) the return of what he essentially is in the fundamental phantasy.

No doubt the scene itself that is involved is veiled. We will return later to this veil. Of what he sees there only emerges this V, like a butterfly's wings, of the open legs of his mother or the Roman V of the time on the clock, this five o'clock of the hot summer when the encounter appears to have taken place. But the important thing, is what he sees in his phantasy, it is S barred itself in so far as it is cut of little o: the little o, are the wolves. And if I go through it today it is because alongside the difficult, abstract discourse that I do not despair of being able to carry, within the limits that we have, to its final details, this object of desire is illustrated here in a way that allows me to accede immediately to concrete elements of structure that I would have more didactic ways of exposing to you. But I do not have the time, and I pass here by way of this non-specular object which is the object of desire, this object which can be found at this frontier zone in function of the images of the subject - let us say to go quickly how many risks of confusion I have here - in the mirror which the big Other constitutes, let us say the space developed by the big Other; because it is necessary to take away this mirror to make of it this sort of mirror which is called, no doubt, not by chance, a witch's mirror. I mean mirrors with a certain concavity which involve in their inside a certain number of concentric ones in which you see your own image reflected as many times as there are mirrors in the big one. The fact is that this is what indeed happens. You have present in the phantasy something which is only definable, accessible along the paths of our experience or perhaps - I know nothing about it, and what is more I do not care about it - along the paths of experiences to which I alluded

earlier. What belongs to the nature of the object of desire and this is interesting because it is a logical reference the object connoted, circumscribed by the Eulerian circles - and I will show you the close structural relationship between the object of this function which is called class and the function of privation, I mean the first of the three terms that I articulated, as privation, frustration and castration. Only, what completely veils the veritable function of privation, even though one can approach it - it is from there that I started to give you the schema of universal and particular propositions. Remember, when I told you: "Every professor is literate" this does not mean that (14) there is only a single professor. The thing is still true for all that. The mainspring of privation, of privation as unary trait, as constituting the function of class is here sufficiently indicated.

But such is the function of dialectical reason - with all due respects to M Lévi-Strauss who believes that it is only a particular case of analytic reason - it is precisely that it does not allow his savage stages to be grasped except by starting with elaborated stages. Now this is not to say that the logic of classes is the savage state of the logic of the object of desire. If it has been possible to establish a logic of classes - I would ask you to consecrate our next meeting to this object - it is because there was the access that was refused to a logic of the object of desire; in other words, it is in the light of castration that one can understand the fruitfulness of the privative theme.

What I only wanted to indicate to you today, is this function which I mapped out for you a long time ago, to show it as exemplary of the most decisive, the cruelest incidences of the signifier in human life, when I told you: jealousy, sexual jealousy requires that the subject knows how to count. The lionesses of the little leonine group that I depicted for you in some zoo or other were manifestly not jealous of one another, because they did not know how to count. We put our finger here on something: it is that it is rather probable that the object as it is constituted at the level of desire, namely the object in function not of privation but of castration, is the only object that can really be numerical. I am not sure that this suffices to affirm that it is enumerable, but when I say that it is numerical I mean that it carries number with it as a quality.

One cannot be sure which one: here there are five in the schema and seven in the text; but what does it matter, there are surely not twelve! When I adventure into such indications, what allows me to do so? Here I tread softly; as in a hazardous interpretation: I await the response. I mean that in indicating this correlation to you, I am proposing to you to notice everything you may be letting pass in terms of the confirmation or of the eventual non-validation in what is presented, what is proposed to you.

(15) Of course you can trust me, I pushed a little bit farther the status of this relationship of the category of the object,

the object of desire with numeration.

But what makes me tread softly here, is that I can give myself time, content myself with telling you that we will see this subsequently, without it remaining for all that any less legitimate to indicate to you here a reference point which if you take it up may clarify certain facts. In any case in Freud's writings what we see at this level, is an image, the libido, he tells us, of the subject has emerged from the experience shattered, zersplittert, zerstort.

My dear friend Leclair does not read German, he did not put the German term in brackets and I did not have time to go and re-verify it. It is the same thing as the term splitting, refendu; the object manifested here in the phantasy carries the mark of what we have called on many occasions the splitting of the subject.

What we find, is undoubtedly here the same topological space which defines the object of desire, it is probable that this number being inherent is only the mark of the inaugural temporality which constitutes this field.

What characterises the double, is what one might call radical repetition; there is in its structure the fact of twice the circuit and the knot here constituted in this twofold circuit is at once this element of the temporal, temporal since in short the question remains open about the way in which developed time which forms part of our discourse is inserted into it; but it is also the essential term through which the logic constituted here is differentiated in an altogether veritable fashion from formal logic as it had subsisted intact in its prestige up to Kant. And this is the problem: where did this prestige come from, given its apparently absolutely dead character for us? The prestige of this logic was entirely in what we have reduced it to ourselves, namely the usage of letters.

The little a's and the little b's of the subject and of the predicate and of their reciprocal inclusion: it is all there. It never contributed anything to anybody; it never brought about the slightest progress in thinking, it remained fascinating (16) throughout the centuries as one of the rare examples which were given us of the power of thinking. Why? It is of no use, but it could serve for something. It would be enough - which is what we are doing - to re-establish the following which is a constitutive miscognition for it: $a = a$ is the principle of identity, this is its principle; we will not say 0 the signifier except to say that it is not the same big 0, the signifier is essentially different to itself, namely that nothing of the subject can be identified to it without excluding itself from it.

A very simple, almost obvious truth, which is enough just by itself to open up the logical possibility of the constitution of the object at the place of this splitting, at the very place even of this difference of the signifier to itself in its subjective effect.

How this object constitutive of the human world - because what it is a question of showing you, is that far from having the slightest aversion to this obvious psychological fact that the human being is likely to take, as one says, his desires for realities, it is here that we ought to follow him. Because since he is right at the beginning, it is only in the furrow opened by his desire that he can constitute any reality whatsoever which falls or not into the field of logic.

It is here that I will take things up the next time. (Applause)

Seminar 26: Wednesday 27 June 1962

Today in the context of the theoretical teaching that we have succeeded this year in going through together, I am indicating to you that I have to choose my axis, as I might say, and I will put the accent on the support-formula of the third type of identification which I noted for you a long time ago, since the time of the graph, under the form of $\$$ which you now know how to read as cut of big $i t o$ [or: cut of big O]. Not what is implicit, nodal in at namely the $\$$, the point thanks to which the eversion from one into the other can take place, thanks to which the two terms present themselves as identical, like the back and the front, not just any back whatsoever and not just any front. Otherwise I would not have needed to show you at the appropriate place what it is when it represents the double cut on this particular surface whose topology I tried to show you in the cross-cap.

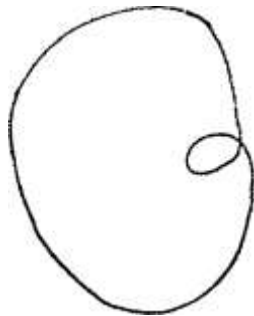

This point designated here is the point (jj) thanks to which the circle indicated by this little cut can be for us the mental schema of an original identification; this point - I believe I have sufficiently indicated its structural function in my last discourses - can, up to a certain point harbour for you too many satisfying properties; here is this phallus with this magical function which is indeed the one that our discourse for a long time now implies in it. It would be a little too easy to find (2) our final resting point here.

This is why today I want to put the accent on this point, namely on the function of o , the small o in so far as it is at the same time properly speaking what can allow there to be conceived the function of the object in analytic theory, namely this object which in psychical dynamics is what structures for us the whole progressive-regressive process, what we have to deal with in our relationships of the subject to his psychical reality, but is also our object, the object of analytic science.

And what I want to put in the foreground, in what I am going to say to you about it today, is that if we want to qualify this object in a properly logical perspective, I stress: logical (logicisante), we have nothing better to say about it except the fact that it is the object of castration. I mean by this, I specify, compared to the other functions of the object defined up to now. Because if one can say that the object in the world, in so far as it is discerned there, is the object of a privation, one can also say that the object is the object of frustration. And I am going to try to show you precisely how this object of ours is distinguished from it.

It is quite clear that if this object is an object of logic it cannot have been up to now completely absent, undisclosed in all the attempts made to articulate as such what is called logic.

Logic has not always existed in the same form. The one which perfectly satisfied, fulfilled us up to Kant, who was still indulgent towards it, this formal logic, born one day from the pen of Aristotle exercised this captivation, this fascination until people devoted themselves, in the last century, to what could be revised in it in detail. It was noticed for example that many things were missing in it as regards quantification. It is certainly not what was added to it which is interesting, but the way it held us. And many of the things that people thought should be added to it only go in a singularly sterile direction.

In fact, it is in the reflection that analysis imposes on us as regards these powers of Aristotelian logic which were so (3) insistent for such a long time, that there can be presented for us the interest of logic. The gaze of someone who strips formal Aristotelian logic of all its so fascinating details must - I repeat to you - abstract itself from the decisive things it has contributed in terms of a cut in the mental world in order even to understand truly what preceded it, for example the possibility of the whole Platonic dialectic which is always read as if formal logic were already there, which completely distorts our reading of it. But let us leave this.

The Aristotelian object - because this indeed is what it must be called - has precisely, as I might say, the property of being able to have properties which belong to it alone: its attributes. And it is these that define classes.

Now this is a construction which he only owes to a confusion of what I would call - for want of anything better - the categories of being and having. This would deserve long developments and, in order to get you to take this step I am obliged to have recourse to an example which will serve as a support.

I already showed you this decisive function of the attribute in the dial: it is the introduction of the unary trait which distinguishes the phasic part where it will be said for example that every trait is vertical, which does not imply in itself the

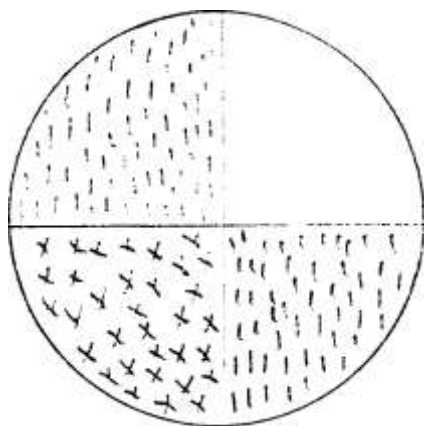

existence of any trait, from the lexical part where there can be vertical traits, but in which there may not be any. To say that every trait is vertical must be the original structure, the function of universality, of universalisation proper to a logic founded on the trait of privation.

Pan is the whole, it evokes some echo or other of the God Pan; we have here one of these mental coalescences that I would ask you to make an effort to strike out of your papers. The name of the God Pan has absolutely nothing to do with the whole, and the panic effects at which he plays in the evening among the simple minds of the countryside have nothing to do with some mystical or other effusion.

The violent alcoholic impulse (raptus), described as panophobic by the old authors, is well named in the sense that something is also hunting him down, is disturbing him, and he jumps out the window. There is nothing to be put into it, it is an error of minds which are too Hellenic to bring to it this retouching with (4) which one of my old masters, whom I nevertheless was very fond of, brought us this rectification: "one ought to speak of pantophobic impulsive action (raptus)". Absolutely not, pan is indeed in effect the whole and, if this refers to something, it is to pagaodai, to possession. And perhaps I will find myself reprovéd if I link this step to the pos of possidero and of possum; but I have no hesitation at all in doing it.

The possession or not of the unary trait, of the characteristic trait, here is what the establishment of a new explicit classificatory logic of the sources of the Aristotelian object will revolve around. I am using this term "classificatoire" intentionally because it is thanks to Claude Lévi-Strauss that you have henceforth the corpus, the dogmatic articulation of the classificatory function at what he calls himself - I will leave the humorous responsibility of it to him - "the savage state", much closer to Platonic dialectic than to Aristotelian, the progressive division of the world into a series of halves, couples of antipodal terms which circumscribe it in types. Therefore, on this subject read La pensée sauvage, you will see that the essential depends on the following: what is not a hedgehog, but what you think should be a shrew or a marmot, is something else.

What characterises the structure of the Aristotelian object, is that what is not a hedgehog is a non-hedgehog. That is why I say that it is the logic of the object of privation.

This can take us much further, to this sort of evasion through which the problem is always posed sharply in this logic of the veritable function of the excluded middle which you know causes

problems at the heart of the most elaborated logic, of mathematical logic.

But we are dealing with a beginning, with a more simple kernel, which I would like to depict for you, as I told you, by an example. And I will not go looking for it very far, but in a proverb which presents in the French tongue a particularity which nevertheless does not spring to the eye, at least for French speakers, the proverb is the following: "All that glitters is not gold, tout ce qui brille n'est pas or".

In colloquial German for example, you must not believe that you can be satisfied with crudely transcribing it: "alles was glanz ist keine Gold". This would not be a good translation. I see Melle Uberfreit nodding approval as she listens to me; she approves of what I am saying: "nicht alles was glanz ist Gold".

(5) This may give greater satisfaction as regards its apparent meaning, putting the accent on the alles, thanks to an anticipation of the nicht which is not at all usual, which forces the genius of the tongue and which, if you reflect on it, misses the sense, because this is not the distinction that is involved.

I could use the Eulerian circles, the same ones that we used the other day in connection with the relationship of the subject to some case or other: all men are liars. Is it simply this that that signifies? The fact is, to recover myself here, a part of what glitters is in the circle of gold and another part is not there. Is that the meaning?



You must not believe that I am the first among the logicians to have paused at this structure and in truth, more than one author who has occupied himself with negation has paused in effect at this problem, not at all so much from the point of view of formal logic, which, as you see, scarcely pauses at it except in order to miscognise it from the point of view of grammatical form, insisting on

the fact that the circuits are ordered in such a fashion that there is precisely put in question the "goldness", if I may express myself in this way, the golden quality of what glitters. The authenticity of the gold goes then in the direction of a radical putting into question; gold here is symbolic of what makes glitter, and if I can put it this way in order to make myself understood, I stress, what gives an object the fascinating colour of desire.

What is important in a formula like this, if I can express myself in this way - forgive me the play on words - is the point d'ORage [the eye of the storm, the golden point] around which there turns the question of what makes something glitter, and in a word, the question of how much truth there is in this glittering.

And, starting from there, of course no gold is going to be true enough to guarantee this point around which there subsists the function of desire.

Such is the radical characteristic of this sort of object that I call small o: it is the object put into question, in so far as one can say that it is what interests us, us analysts, as what (6) interests someone listening to any teaching. It is not for nothing that I saw nostalgia arising on the lips of the person who wanted to say: "Why does he not say", as someone put it, "the truth about the truth?". It is truly a great tribute to a discourse which takes place every week in this senseless position of being here behind a table in front of you articulating this sort of account which one is quite content normally to see always avoiding such a question.

If it were not a matter of the analytic object, namely the object of desire, raising such a question would never even be dreamt of, except on the lips of a Huron who might imagine that when one comes to the University it is in order to know "the truth about the truth". Now this is what is involved in analysis. One could say that it is the mirage of this that we are, often in spite of ourselves, embarrassed to polish up in the spirit of those to whom we address ourselves. We find ourselves, I am really saying, embarrassed, like the poison of the proverbial apple; and nevertheless it is really what is there, this is what we are dealing with, it is on it, in so far as it is at the heart of the structure, it is on it that there is brought to bear what we call castration.

It is precisely in so far as there is a hard, suggestive structure which turns around a kind of cut - the one which I represented for you in this way - that there is at the heart of phantastical identification this organizing object, this inducing object. And it could not be otherwise as regards the whole world of anxiety with which we have to deal, which is the object defined as object of castration.

Here I want to remind you about the surface from which there is borrowed this part which I described for you the last time as enucleated, which gives the very image of the circle in terms of which this object can be defined. I want to image for you what the property of this circle with the double circuit is. Magnify progressively the two lobes of this cut so that they both pass, as I might say, behind the anterior surface. There is nothing new about that, it is the way I already demonstrated to you of displacing this cut. One has only in effect to displace it and one makes it appear very easily that the complementary part of the surface, with respect to what is isolated around what one can call the two central leaves, or the two petals, to make them connect up with one another - the inaugural metaphor of the cover of Claude Lévi-Strauss' book, with this very image - what remains is an apparent lotus-surface.

It is the same figure that you rediscover here. What is found in effect between the two poles displaced in this way from the

two loops (boucles) of the cut, at the moment that these two edges come close together, is a lotus-surface. But what I want to show you here, is that in order that this double cut should connect up, close on itself, which is what seems to be indicated in its very structure, you should spread little by little the interior loop of the interior eight. This indeed is what you hope for from it, it is that it will be satisfied by its own overlapping of itself, that it fits into some sort of norm, that one knows what one is dealing with, what is outside and what is inside, which this state of the figure shows you, because you clearly see how it must be seen.

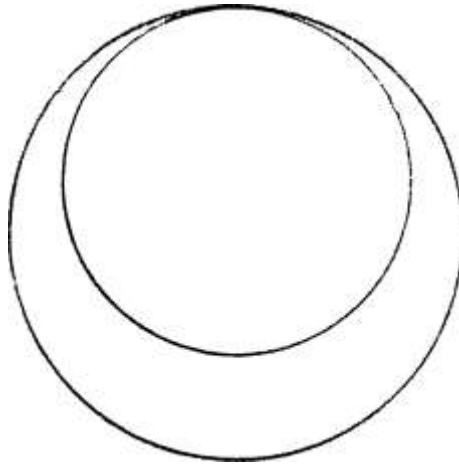

This lobe has been extended from the other side, it has spread onto the other face 2; it visibly shows us that the outside loop is going, on this surface, to rejoin the inside loop on condition that it passes by the outside. The surface of projective planes is completed, closed, finished. The object defined as our object, the object which forms the world of desire only rejoins its intimacy by a centrifugal path.

What does that mean? What do we find there? I am taking things from further back. The function of this object is linked to the relationship through which the subject is constituted in his relationship to the locus of the Other, big O, which is the locus where there is ordered the reality of the signifier. It is at the point where every significance is missing, is abolished, at the nodal point called that of the desire of the Other, at the phallic point, in so far as it signifies the abolition as such of all significance, that the object little o, the object of castration, comes to take its place.

There is therefore a relationship to the signifier, and that is why here again I must remind you of the definition from which I began this year concerning the signifier: the signifier is not the sign: and the ambiguity of the Aristotelian attribute, is (7) precisely to want to naturalise it, or to make the sign natural: "every tricoloured cat is female". The signifier, as I told you, is, contrary to the sign which represents something for

someone, what represents the subject for another signifier. And there is no better example than the seal.

What is a seal? The day after the day when I gave you this formula, it happened that a friend of mine who is an antique dealer put into my hands a little Egyptian seal, which, in an unusual way but one which is not rare either, was in the shape of a sole with, on the top, the toes and the back drawn in. The seal, as you will have understood, I found in the texts, it is indeed that: a trace as one might say - and it is true that nature abounds in them - but this can only become a signifier if you go around this trace with a pair of scissors and cut it out. If you extract the trace afterwards, it can become a seal. And I think that the example already sufficiently illuminates things for you: a seal represents the subject, the sender - not necessarily for the addressee: a letter can always remain sealed; but the seal is there: for the letter, it is a signifier.

Well then, the object little o, the object of castration participates in the nature thus exemplified of this signifier. It is an object structured like that. In fact, you will notice that at the end of what the centuries have been able to dream up about the function of knowledge, that is all we have in our hand. In nature, there is something of the thing (de la chose), if I can express myself in that way, which is presented with an edge. Everything that we can conquer in it, which simulates a knowledge is never anything more than detaching this edge and not to make

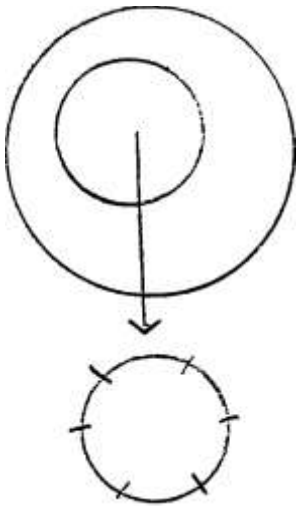

use of it, but to forget it in order to see the remainder which, a curious thing, finds itself completely transformed by this extraction, exactly as the cross-cap images it for you, namely, do not forget what a cross-cap is. It is a sphere. I already told you; it is necessary, one cannot do without the bottom of this sphere. It is a sphere with a hole, which you organise in a certain way, and you can very well imagine that it is by pulling on one of the edges that you make appear, more or less by holding onto it, this something which is going to block the hole provided you realise that each of these points is joined to the opposite point, which naturally creates

(8) considerable intuitive difficulties and ones which even obliged us to carry out the whole construction that I detailed before you, in the shape of the cross-cap imaged in space.

So what? What is the important thing? It is that, by this operation which is produced at the level of the hole, the remainder of the sphere is transformed into a Mobius surface by the enucleation of the object of castration. The entire world is ordered in a certain fashion, which gives us, as I might say, the illusion of being a world. And I would even say that, in a certain fashion, to make an intermediary state between this

Aristotelian object where this reality is in a way masked and our object that I am trying here to put forward for you, I would introduce into the middle this object which inspires in us at the same time the greatest mistrust because of the inherited prejudices of an epistemological education, but which is of course our great temptation - those of us in analysis, if we had not had the existence of Jung to exorcise it we would perhaps not even notice the degree to which we still believe in it - it is the object of Naturwissenschaft, it is the Goethean object, as I might say, the object which in nature reads, ceaselessly like an open book all the figures of an intention that would have to be called quasi-divine if the term God had not been so well preserved from another side.

This, let us say it, demonic rather than divine Goethean intuition which made him moreover read in the skull found on the Lido the completely imaginary shape of Werther or forge the theory of colours, in short leaves for us the traces of an activity of which the least one can say is that it is cosmogenic, engendering the oldest illusions of the micro-macroscopic analogy and nevertheless still captivating for a spirit so close to us.

What does that depend on? To what do we attribute the exceptional fascination that the personal drama of Goethe exercises on us if not to the flowering as central to that drama, in his case, of desire. "Warum Goethe liebt Frederique?" wrote, as you know, in an article, one of the survivors of the first generation, Theodor Reik.

The specificity and the fascinating character of Goethe's personality is that in it we read in all its presence the identification of the object of desire to what must be renounced (9) in order that the world as world should be delivered to us.

I very sufficiently recalled the structure of this case by showing in it the analogy with the one developed by Freud in the story of the Ratman, in "The individual myth of the neurotic". Or rather it was published somewhere without my consent, because I neither revised nor corrected this text, which makes it almost unreadable; nevertheless it has been hanging around here and there and one can find the broad lines of it

In this complementary relationship of o, the object of a constitutive castration where our object as such is situated, with this remainder and where we cannot read everything, and especially our figure i(o), it is this that I tried to illustrate this year for you at the high point of my discourse.

In the specular illusion, in the fundamental miscognition with which we always have to deal, does o takes on the function of specular image under the form of i of o even though, as I might say it has no similarity with it. It could not in any way read its image in it for the good reason that, if this \bar{i} is something, it is not the complement of small i factor of small o, it could just as well be the cause of it, we will say - and I am employing this term intentionally, because for some time

precisely, ever since the categories of logic have been shaken a little, cause - good or bad - has not in any case had a good press and people prefer to avoid speaking about it.

And in effect there is scarcely anybody but we who can find our way in this function whose ancient shade in short one cannot approach after the mental progress that has taken place, except by seeing in it some sort of identical of everything that is manifested as effects, but when they are still veiled. And of course this has nothing satisfying about it, except perhaps if precisely it is not by being at the place of something, by cutting all its effects, that the cause sustains its drama. If there is as well moreover a cause which is worth our while becoming attached to, at least by our attention, it is not always and in advance a lost cause.

Therefore we can articulate that if there is something on which we ought to put the accent rather than avoiding it, it is that (10) the function of the partial object could not in any way be reduced for us, if what we call partial object is what designates the point of repression because of its loss.

And it is starting from there that there takes root the illusion of the cosmicity of the world. This acosmic point of desire in so far as it is designated by the object of castration, is what we ought to preserve as the pivotal point, the centre of every elaboration of what we have to accumulate as facts concerning the constitution of the objectal world. But this object \circ that we see arising at the point of the failure of the Other, at the point of the loss of the signifier because this loss is the loss of this object itself, of the never rediscovered member of the dismembered Horus, how can we not give this object what I will call by way of parody its reflexive property, as I might say, because it is from it that it starts, that it is in as much as the subject is first of all and uniquely essentially cutting of this object that something can be born which is this interval between the flesh and the hide between Wahrnehmung and Bewusstsein, between perception and consciousness which is Selbstbewusstsein. It is here that it is worth stating its place in an ontology founded on our experience. You will see that it rejoins here a formula commented on at length by Heidegger, in its pre-Socratic origin.

The relationship of this object to the image of the world which orders it, constitutes what Plato called properly speaking the dyad provided we notice that in this dyad the subject $\$$ barred and the \circ are at the same side: to auto einai kai noiig. This formula which for a long time was used to confuse what is not sustainable, being and knowledge, means nothing other than that.

Compared to the correlative little \circ , to what remains when the constitutive object of the phantasy has separated itself, being and thinking are on the same side, on the side of \circ . Small \circ is being in so far as it is essentially missing in the text of the world. And that is why around little \circ there can slide everything that is called the return of the repressed, namely

that here there is betrayed the true truth which interests us and which is always the object of desire, in so far as the whole of humanity, the whole of humanism is constructed to make us miss it.

We know from our experience that nothing has any veritable weight in the world except something which makes an allusion to this object of which the Other, big O takes the place to give it a (11) meaning.

Every metaphor, including that of the symptom tries to make this object emerge in its signification, but all the pullulation of meanings that it may engender never manages to staunch what is involved in this hole in terms of a central loss.

Here is what regulates the relationships of the subject with the Other, O, what regulates secretly but in a fashion which is surely not less efficacious than this relationship of small o to the imaginary reflection which covers and surmounts it. In other words that on the road, the only one that is open to us to rediscover the incidence of this little o, we encounter first of all the mark of the occultation of the Other, under the same desire.

Such in effect is the way: o can be approached along this way which is that the Other, with a big O, desires in the failing subject, in the phantasy, the \$ barred. This is why I taught you that the fear of desire is experienced as equivalent to anxiety, that anxiety is the fear of what the Other in himself desires of the subject, this "in himself" founded precisely on the ignorance of what is desired at the level of the Other. It is from the side of the Other that the little o comes to light, not so much as lack but as to be.

This is why we come here to pose the question of its relationship to the thing, not the sacred one, but what I described to you as das Ding. You know that in leading you to this limit I did nothing other than indicate to you that here the perspective is inverted, this small i of small o which envelopes this access to the object of castration is here the very image which creates an obstacle in the mirror, or rather, in the way it happens in obscure mirrors - one must always think of this obscurity every time that in the ancient authors you see intervening a reference to the mirror - something can appear beyond the image that the clear mirror gives. It is to the image of the clear mirror that there is hooked on this barrier which I called at the time that of beauty. Moreover the revelation of little o beyond this image, even if it appears under the most horrible form, will always preserve its reflection.

And it is here that I would like to share with you the happiness (12) that I had in encountering these thoughts in the writings of someone whom I consider to be quite simply the poet of our literature, who has certainly gone further than anyone in the present or the past along the path of the realisation of the phantasy. I am talking about Maurice Blanchot whose death

sentence was for me for a long time the surest confirmation of what I was saying for a whole year in the seminar on Ethics about the second death.

I had not read the second version of his first work Thomas l'Obscur. I think that none of you, after what I am going to read you of it, will fail to test yourselves against such a small volume. Something is encountered there which incarnates the image of this object o, in connection with which I spoke about horror; it is the term that Freud uses when he is dealing with the Ratman. Here it is something about rats that is involved.

Georges Bataille wrote a long essay which turns around the well-known central phantasy of Marcel Proust, which also concerns a rat: Histoire de rat. But do I need to tell you that if Apollo riddles the Greek army with the arrows of the plague, it is because, as M Gregoire very well noted, if Aesclepius, as I taught you a long time ago is a mole - not so long ago I discovered the plan of a molehill in a tolos (?), a further one that I visited recently - if then Aesclepius is a mole, Apollo is a rat.

Here it is. I am anticipating, or more exactly I am taking Thomas l'Obscur a little earlier on - it is not by chance that he is called that -:

"And in his room, those who entered, seeing his book always open at the same pages, thought he was pretending to read. He read with an unsurpassable minuteness and attention. He was aware of every sign of the situation that the male finds himself in when the praying mantis is going to devour him. They were looking at one another. The words, issuing from a book took on there a mortal power, exercised on the look which touched them a soft and peaceful attraction. Each one of them, like a half-closed eye, allowed there to enter a too lively gaze that in other circumstances it would not have tolerated.

Thomas slipped along then towards these corridors which he approached without defence until the moment he was (13) glimpsed by the intimacy of the word. It was not yet terrifying, it was on the contrary an almost agreeable moment that he would have liked to prolong. The reader joyously considered this little spark of life which he did not doubt he had awoken. He saw himself with pleasure in this eye which saw him; his pleasure itself became very great, it became so great, so pitiless that he underwent it with a sort of terror and that having raised himself up, an intolerable moment, without receiving from his interlocutor a sign of complicity, he perceived the whole strangeness that there was in being observed by a word as if by a living being. And not alone by a word, but by all those which accompanied it and which in their turn contained in themselves other words, like a succession of angels opening out to infinity even to the very eye of the absolute."

I will pass over the steps which go by way of this "while perched on his shoulders the word it and the word I began their carnage", to the confrontation that I was aiming at in evoking this passage for you:

"His hands tried to touch an impalpable and unreal body. It was such a horrible effort that this thing which drew away from him and in drawing away tried to attract him, appeared to him the same as the one that got unspeakably closer. He fell to the ground. He had the feeling of being covered with impurities, each part of his body underwent an agony, his face was forced to touch evil, his lungs to breathe it. He was there on the floor, twisting himself, then entering into himself, then emerging. He crawled heavily scarcely different from the serpent that he would have wished to become in order to believe in the venom that he felt in his mouth. It was in this state that he felt himself bitten or struck, he could not know which, by what seemed to him to be a word but which resembled rather a gigantic rat, with piercing eyes, with pure teeth, an all-powerful beast. Seeing it a few inches from his face he could not escape from the desire to devour it, to draw it into the most profound intimacy with himself; he threw himself on it and digging his nails into its entrails, he tried to make it his own.

(14) The end of the night came. The light which shone through the shutters was extinguished. But the struggle with the terrible beast, which had finally revealed itself to be of an incomprehensible dignity and magnificence lasted for an immeasurable time. This struggle was horrible for the being lying on the floor grinding his teeth, frowning his face, tearing out his eyes in order to get the animal to enter, and who would have looked like a demon if he had not resembled a man. It was almost too beautiful for this sort of black angel, covered with red hairs, with sparkling eyes.

Sometimes one believed he had triumphed and he saw descending into himself with an ungovernable nausea, the word innocence defiling him; sometimes the other devoured him in his turn, dragged him back through the hole through which it had come, then rejected him like a hard and empty body.

On every occasion, Thomas was repulsed to the very foundations of his being by the very words which had haunted him and which he had pursued like his nightmare and like the explanation of his nightmare. He discovered himself still more empty and more heavy, he no longer stirred except with an infinite fatigue. His body, after such a struggle became entirely opaque and to those who regarded it, he gave the restful impression of sleep even though he had been ceaselessly awake."

You can read the rest yourselves.

And the path of what Maurice Blanchot uncovers for us does not stop there. If I took the trouble here to indicate this passage to you, it is because as the time comes for me to leave you this year I want to tell you that I am often aware of doing nothing here other than allowing you to advance with me to the point that all around us many of the best people have already got to.

Other people have noted the parallel between some of the researchs that are being carried on at present and the ones that we are elaborating here together. I would have no trouble reminding you that on other paths, the works and then the reflections on the works by himself of Pierre Klossowski converge with this path of research into phantasy as we have elaborated it (15) this year.

Small i of small o and small o, their difference, their complementarity and the mask that one constitutes for the other, this is where I have led you this year. Small i of small o, its image, is therefore not its image, it does not represent it, this object of castration. It is not in any way this representative of the drive on which repression is brought to bear electively. And for a double reason: the fact is that it is not, this image, either the Vorstellung because it is itself an object, a real image - consult what I wrote on this subject in my observations on the report of Daniel Lagache, - nor an object which is not the same as small o, which is not its representative either. i(o) and o.

Desire, you must not forget, is situated where in the graph? It aims at the phantasy \$ barred out of little o, in a mode analogous to that of e where the ego refers itself to the specular image. What does that mean, if not that there is some relationship of this phantasy to the desirer himself. \$4 o

But can we make of this desirer purely and simply the agent of desire? Let us not forget that at the second stage of the graph d, desire is a "who" who responds to a question, which is not aimed at a "who", but a "Che vuoi?". To the question: "Che vuoi?" the desirer is the response, the response which is not designated by the who of "who wants?", but the response of the object. What I want in the phantasy determines the object from which the desirer that it contains must avow himself as desirer.

Look for him always, this desirer, at the core of any object of desire, and do not put up necrophilic perversion as an objection because precisely this is the example where it is proved that on this side of (en-deca) the second death physical death still leaves something to be desired and that the body allows itself be grasped there as entirely caught up in the function of the signifier, separated from itself and a witness to what the necrophilic embraces: an ungraspable truth.

This relationship of the object to the signifier, before leaving you, let us come back to the point that these reflections are based on, namely to what Freud himself marked about the identification of desire (in parentheses in the case of the

hysteric) to the desire of the Other. The hysteric shows us clearly in effect the distance between this object and the signifier, this distance which I defined by the lack of the signifier but implying its relation to the signifier. In effect, it is to this that the hysteric identifies herself when, Freud tells us, it is the desire of the Other with regard to which she orientates herself and which started her hunting.

(16) And, it is on this that the affects, he tells us, the emotions considered here in his writing as entangled, if I may express myself in this way, with the signifier, and taken up as such. It is in this connection that he tells us that all the confirmed emotions, what I might call the conventional forms of emotion are nothing other than ontogenetic inscriptions of what he compares, of what he reveals as expressly equivalent to hysterical attacks, which is to come back to the relationship to the signifier.

The emotions are in a way the leavings (caduques) of behaviour, the fallen parts taken up as signifying. And what is most tangible, everything that we can see about them, is found in antique forms of fighting. Let those who have seen the film Rashomon remember the strange interludes which suddenly suspend the combatants who carry out each one separately three little circuits around themselves, make a paradoxical genuflection to some unknown part or other of space. This forms part of the fight, just as in the sexual parade Freud teaches us to recognise this type of interruptive paradox of incomprehensible scansions.

If something about emotions is shown to us in the case of the hysteric, it is precisely when she is on the track of desire, it is this clearly mimicked characteristic which is described as being out of place, which deceives you and from which you draw an impression of falseness. What does it mean, if not that the hysteric of course can do nothing other than seek the desire of the Other where it is, where it leaves its trace in the other, in Utopia, or indeed in atopia, distress, even fiction; in short it is along the path of display as one might expect, that all the symptomatic aspects are shown. And if these symptoms find this path already opened out, it is in liaison with this relationship that Freud designates to the desire of the Other.

I had something else to point out to you about frustration. Of course, what I brought you this year about the relationship to the body, what is only outlined in the way in which I gave you in a mathematical corpus the beginnings of all sorts of paradoxes concerning the idea that we can have of the body, finds its applications undoubtedly well designed to modify profoundly the idea that we may have of frustration as a sort of lack which concerns a gratification referred to what is supposed to be a so-called primitive totality as people would like to see it (17) designated in the relationships of the mother and the child.

It is strange that analytic thinking has never encountered on this path except as always in corners of Freud's observations - and here I am designating the word Schleier - this caul with

which the child is born and which hangs around analytical literature without it being ever dreamt that we had here the beginning of a very fruitful path: the stigmata.

If there is something which allows some primary narcissism or other to be conceived of as involving a totality - and here I can only regret that someone who posed me the question has absented himself - it is undoubtedly the reference of the subject, not so much to the body of the host mother, but to these lost envelopes where there is so well read this continuity between the inside and the outside, which is the one to which my model of this year introduced you, to which we will have to return.

Simply I want to indicate to you, because we will rediscover it subsequently, that if there is something in which there ought to be accentuated the relationship to the body, to incorporation, to Einverleibung, it is on the side of the father who is entirely left to one side that you should look.

I left him entirely to one side because I would have had to introduce you - but when will I do it - to a whole tradition which is called mystical and which undoubtedly, by its presence in the Semitic tradition, dominates the whole personal adventure of Freud.

But if there is something that one demands of the mother, does it not appear to you to be striking that it should be the only thing that she does not have, namely the phallus? The whole dialectic of these last years, up to and including the Kleinian dialectic, which nevertheless gets closest to it, remains falsified because the accent is not put on this essential divergence. The fact is moreover that it is impossible to correct it, impossible also to understand anything about what constitutes the impasse of the analytic relationship, and very especially in the transmission of analytic truth as didactic analysis carries it out. The fact is that it is impossible to introduce into it the relationship to the father, that one is not the father of one's analysand. I have said enough and done enough to ensure that no-one would dare any longer, at least in any entourage that is close to mine, risk advancing that one can be his mother. This nevertheless is what is involved.

(18) The function of analysis as it is inserted where Freud left it to us with its open future, its gaping trace, is situated where the pen fell from his hand in connection with the article on the splitting of the ego at the ambiguous point which brings the following; the object of castration is this term which is ambiguous enough for it to happen that at the very moment that the subject has busied himself with repressing it he establishes it more firmly than ever in an Other.

So long as we have not recognised that this object of castration is the very object through which we situate ourselves in the field of science, I mean that it is the object of our science as number or quantity may be the object of mathematics, the dialectic of analysis, not only its dialectic but its practice,

its relationship even and even the structure of its community will remain in suspense.

Next year, I will deal for you, pursuing strictly the point at which I left you today, with anxiety.